



Advanced Test Equipment Rentals
www.atecorp.com 800-404-ATEC (2832)



Model 5080

GAUSS / TESLA METER

Instruction Manual

Manual UN-01-231
Rev. F, ECO 13095
Item No. 359926
Sypris Test & Measurement
All rights reserved.





This symbol appears on the instrument and probe. It refers the operator to additional information contained in this instruction manual, also identified by the same symbol.

NOTICE:

**See Pages 3-1 and 3-2
for SAFETY
instructions prior to first use !**

Table of Contents

SECTION-1 INTRODUCTION

Understanding Flux Density.....	1-1
Measurement of Flux Density.....	1-2
Product Description.....	1-5
Applications.....	1-6

SECTION-2 SPECIFICATIONS

Instrument.....	2-1
Standard Transverse Probe.....	2-5
Standard Axial Probe.....	2-6
Optional Probe Extension Cable.....	2-7
Zero Flux Chamber.....	2-8

SECTION-3 OPERATING INSTRUCTIONS

Operator Safety.....	3-1
Operating Features.....	3-3
Instrument Preparation.....	3-6
Power-Up.....	3-8
Power-Up Settings.....	3-9
Low Battery Condition.....	3-10
Overrange Condition.....	3-11
AC or DC Measurement Selection.....	3-12
UNITS of Measurement Selection.....	3-13
RANGE Selection.....	3-14
HOLD Mode Selection.....	3-16
MIN / MAX Hold Usage.....	3-17
Peak Hold Usage.....	3-18
ZERO Function.....	3-20
Automatic ZERO Function.....	3-21
Manual ZERO Function.....	3-23
RELATIVE Mode.....	3-25
Automatic RELATIVE Mode.....	3-28

Manual RELATIVE Mode.....	3-30
ANALOG OUTPUT Function.....	3-31
Analog Output Usage.....	3-33
Sources of Measurement Errors.....	3-35
More details on AC Mode Operation.....	3-38
More details on DC Mode Operation.....	3-40

SECTION-4 REMOTE OPERATION

RS-232 Interface Parameters.....	4-1
RS-232 Interface Connection.....	4-1
Remote Command Standards.....	4-3
Command Format.....	4-4
Message Terminators.....	4-4
Error Buffer.....	4-5
Status Registers.....	4-5
Status Byte and Request For Service (RQS).....	4-6
Standard Event Register.....	4-9
Measurement Event Register.....	4-10
Operation Event Register.....	4-10
Questionable Event Register.....	4-11
“Common” Command Syntax.....	4-11
“Common” Commands.....	4-13
SCPI Command Syntax.....	4-16
SCPI Commands.....	4-18
Error Messages and Commands.....	4-21
Status Commands.....	4-23
MODE Commands.....	4-25
RANGE Commands.....	4-26
HOLD Commands.....	4-27
ZERO Command.....	4-28
RELATIVE Commands.....	4-28
MEASUREMENT Command.....	4-29
ANALOG OUTPUT Command.....	4-30
Intermixing Common and SCPI commands.....	4-31
Using Query Commands.....	4-31

Using the Operation Complete Status.....	4-32
Example Program.....	4-33
WARRANTY	5-1

List of Tables

Table 4-1	Common Command Summary.....	4-13
Table 4-2	SCPI Command Summary.....	4-18

List of Illustrations

Figure 1-1	Flux Lines of a Permanent Magnet.....	1-1
Figure 1-2	Hall Generator.....	1-3
Figure 1-3	Hall Probe Configurations.....	1-4
Figure 2-1	Standard Transverse Probe.....	2-5
Figure 2-2	Standard Axial Probe.....	2-6
Figure 2-3	Optional Probe Extension Cable.....	2-7
Figure 2-4	Zero Flux Chamber.....	2-8
Figure 3-1	Auxiliary Power Connector Warnings.....	3-1
Figure 3-2	Probe Electrical Warning.....	3-2
Figure 3-3	Operating Features.....	3-3
Figure 3-4	Battery Installation.....	3-6
Figure 3-5	Probe Connection.....	3-7
Figure 3-6	Power-Up Display.....	3-8
Figure 3-7	Missing Probe Indication.....	3-9
Figure 3-8	Low Battery Indication.....	3-11
Figure 3-9	Overrange Indication	3-11
Figure 3-10	MODE (AC-DC) Function.....	3-12
Figure 3-11	UNITS Function.....	3-13
Figure 3-12	RANGE Function.....	3-15

Figure 3-13	HOLD Function.....	3-17
Figure 3-14	Automatic ZERO Function.....	3-22
Figure 3-15	Manual ZERO Function.....	3-24
Figure 3-16	RELATIVE Function.....	3-28
Figure 3-17	Automatic RELATIVE Function.....	3-29
Figure 3-18	Manual RELATIVE Function.....	3-31
Figure 3-19	OUTPUT Function.....	3-32
Figure 3-20	LO and HI Analog Output Displays.....	3-34
Figure 3-21	Adjusting the DC Offset of the Analog Output.....	3-35
Figure 3-22	Probe Output versus Flux Angle.....	3-36
Figure 3-23	Probe Output versus Distance.....	3-37
Figure 3-24	Flux Density Variations in a Magnet.....	3-37
Figure 3-25	Low AC Signal Indication.....	3-39
Figure 4-1	9-Pin Interface Connector.....	4-2
Figure 4-2	Serial Port Connection Schemes.....	4-3
Figure 4-3	Condition, Event and Enable registers.....	4-6
Figure 4-4	Status Byte and Enable registers.....	4-7
Figure 4-5	Standard Event register.....	4-9
Figure 4-6	Measurement Event register.....	4-10
Figure 4-7	Operation Event register.....	4-10
Figure 4-8	Questionable Event register.....	4-11

Section 1

Introduction

UNDERSTANDING FLUX DENSITY

Magnetic fields surrounding permanent magnets or electrical conductors can be visualized as a collection of magnetic *flux* lines; lines of force existing in the material that is being subjected to a magnetizing influence. Unlike light, which travels away from its source indefinitely, magnetic flux lines must eventually return to the source. Thus all magnetic sources are said to have two *poles*. Flux lines are said to emanate from the “north” pole and return to the “south” pole, as depicted in Figure 1-1.

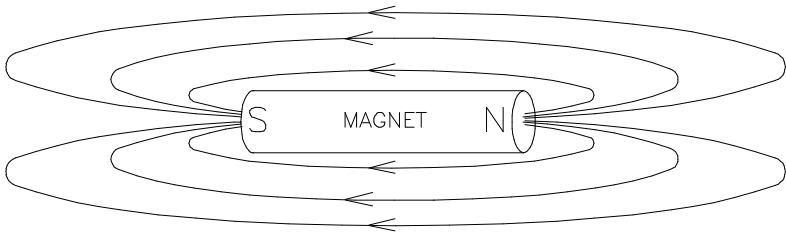

Figure 1-1
Flux Lines of a Permanent Magnet

One line of flux in the CGS measurement system is called a *maxwell* (M), but the *weber* (W), which is 10^8 lines, is more commonly used.

Flux density, also called magnetic induction, is the number of flux lines passing through a given area. It is commonly assigned the symbol “*B*” in scientific documents. In the CGS system a *gauss* (G) is one line of flux passing through a 1 cm^2 area. The more

INTRODUCTION

commonly used term is the *tesla* (T), which is 10,000 lines per cm^2 . Thus

$$1 \text{ tesla} = 10,000 \text{ gauss}$$

$$1 \text{ gauss} = 0.0001 \text{ tesla}$$

Magnetic field strength is a measure of force produced by an electric current or a permanent magnet. It is the ability to induce a magnetic field "*B*". It is commonly assigned the symbol "*H*" in scientific documents. The unit of "*H*" in the CGS system is an *oersted* (Oe), but the *ampere-meter* (Am) is more commonly used. The relationship is

$$1 \text{ oersted} = 79.6 \text{ ampere-meter}$$

$$1 \text{ ampere-meter} = 0.01256 \text{ oersted}$$

It is important to know that magnetic field strength and magnetic flux density are not the same. Magnetic field strength deals with the physical characteristics of magnetic materials whereas flux density does not. The only time the two are considered equal is in free space (air). Only in free space is the following relationship true:

$$1 \text{ G} = 1 \text{ Oe} = 0.0001 \text{ T} = 79.6 \text{ Am}$$

MEASUREMENT OF FLUX DENSITY

A device commonly used to measure flux density is the *Hall generator*. A Hall generator is a thin slice of a semiconductor material to which four leads are attached at the midpoint of each edge, as shown in Figure 1-2.

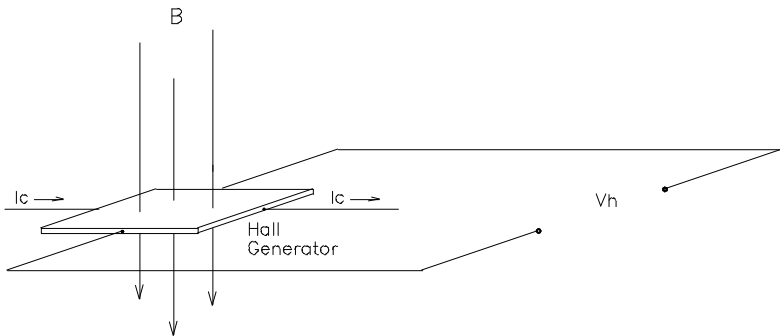

Figure 1-2
Hall Generator

A constant current (I_c) is forced through the material. In a zero magnetic field there is no voltage difference between the other two edges. When flux lines pass through the material the path of the current bends closer to one edge, creating a voltage difference known as the Hall voltage (V_h). In an ideal Hall generator there is a linear relationship between the number of flux lines passing through the material (flux density) and the Hall voltage.

The Hall voltage is also a function of the *direction* in which the flux lines pass through the material, producing a positive voltage in one direction and a negative voltage in the other. If the same number of flux lines pass through the material in either direction, the net result is zero volts. This sensitivity to flux direction makes it possible to measure both static (dc) and alternating (ac) magnetic fields.

The Hall voltage is also a function of the *angle* at which the flux lines pass through the material. The greatest Hall voltage occurs when the flux lines pass perpendicularly through the material. Otherwise the output is related to the cosine of the difference between 90° and the actual angle.

INTRODUCTION

The sensitive area of the Hall generator is generally defined as the largest circular area within the actual slice of the material. This *active area* can range in size from 0.2 mm (0.008") to 19 mm (0.75") in diameter. Often the Hall generator assembly is too fragile to use by itself so it is often mounted in a protective tube and terminated with a flexible cable and a connector. This assembly, known as a *Hall probe*, is generally provided in two configurations:

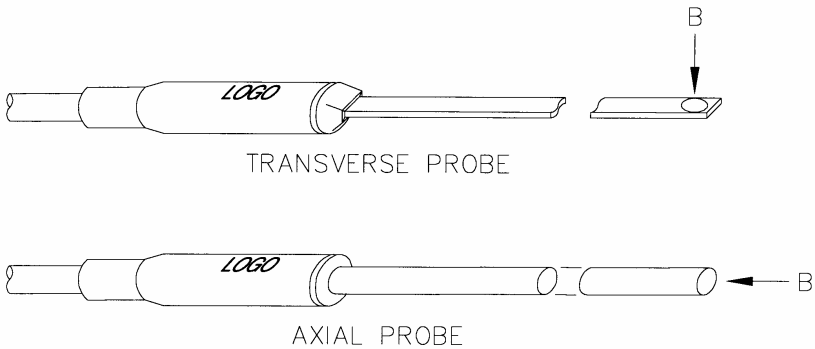

Figure 1-3
Hall Probe Configurations

In "transverse" probes the Hall generator is mounted in a thin, flat stem whereas in "axial" probes the Hall generator is mounted in a cylindrical stem. The axis of sensitivity is the primary difference, as shown by " B " in Figure 1-3. Generally transverse probes are used to make measurements between two magnetic poles such as those in audio speakers, electric motors and imaging machines. Axial probes are often used to measure the magnetic field along the axis of a coil, solenoid or traveling wave tube. Either probe can be used where there are few physical space limitations, such as in geomagnetic or electromagnetic interference surveys.



Handle the Hall probe with care. Do not bend the stem or apply pressure to the probe tip as damage may result. Use the protective cover when the probe is not in use.

PRODUCT DESCRIPTION

The *MODEL 5080 GAUSS / TESLAMETER* is a portable instrument that utilizes a Hall probe to measure magnetic flux density in terms of gauss, tesla or ampere-meter. The measurement range is from 0.01 mT (0.1 G or 0.01 kAm) to 2.999T (29.99 kG or 2387 kAm). The instrument is capable of measuring static (dc) magnetic fields and alternating (ac) fields.

The *MODEL 5080* consists of a palm-sized meter and various detachable Hall probes. The meter operates on standard 9 volt alkaline batteries or can be operated with an external ac-to-dc power supply. A retractable bail allows the meter to stand upright on a flat surface. A notch in the bail allows the meter to be wall mounted when bench space is at a premium. The large display is visible at considerable distances. The instrument is easily configured using a single rotary selector and two pushbuttons.

Three measurement ranges can be selected or the meter can automatically select the best range based on the present flux density being measured. A “zero” function allows the user to remove undesirable readings from nearby magnetic fields (including earth’s) or false readings caused by initial electrical offsets in the probe and meter. Included is a “zero flux chamber” which allows the probe to be shielded from external magnetic fields during this operation. Another feature called “relative mode” allows large flux readings to be suppressed so that small variations within the larger field can be observed directly. Both the “zero” and “relative” adjustments can be made manually or automatically.

INTRODUCTION

Other features include three “hold” modes, allowing either the arithmetic maximum, minimum or true peak values to be held indefinitely until reset by the user. An analog signal is available from a standard BNC connector that is representative of the magnetic flux density signal and is calibrated to ± 3 volts full scale in dc mode or 3 Vrms in ac mode. This output can be connected to a voltmeter, oscilloscope, recorder or external analog-to-digital converter.

The meter can be fully configured and flux density readings acquired from a remote computer or PLC using the RS-232 communications port. This is a standard 9-pin “D” connector commonly used in personal computers. The commands follow widely accepted protocols established by the IEEE-488.2 and SCPI-1991 standards.

The meter, probes and accessories are protected when not in use by a sturdy carrying case.

APPLICATIONS

- Sorting or performing incoming inspection on permanent magnets, particularly multi-pole magnets.
- Testing audio speaker magnet assemblies, electric motor armatures and stators, transformer lamination stacks, cut toroidal cores, coils and solenoids.
- Determining the location of stray fields around medical diagnostic equipment.
- Determining sources of electromagnetic interference.
- Locating flaws in welded joints.
- Inspection of ferrous materials.
- 3-dimensional field mapping.
- Inspection of magnetic recording heads.

Section 2

Specifications

INSTRUMENT

RANGE			RESOLUTION		
GAUSS	TESLA	Am	GAUSS	TESLA	Am
300 G	30 mT	23 kAm	0.1 G	0.01 mT	0.01 kAm
3 kG	300 mT	238 kAm	1 G	0.1 mT	0.1 kAm
30 kG	3 T	2388 kAm	10 G	1 mT	1 kAm

ACCURACY (reading on display and from RS-232 port, including probe)

dc mode:	$\pm 1\%$ of reading, ± 3 counts
ac mode:	
20 - 10,000 Hz:	$\pm 2.5\%$ of reading, ± 5 counts
10,000 - 20,000 Hz:	$\pm 5\%$ of reading, ± 5 counts

ACCURACY (analog output, including probe)

dc mode:	$\pm 1\%$ of reading, ± 5 mV.
ac mode, low range:	
20 - 2000 Hz:	$\pm 3\%$ of reading, ± 5 mV
7,000 Hz:	- 3 dB (typical)
ac mode, mid and high range:	
20 - 3500 Hz:	$\pm 3\%$ of reading, ± 5 mV
13,000 Hz:	- 3 dB (typical)

WARMUP TIME TO RATED

ACCURACY: 15 minutes

SPECIFICATIONS

MIN / MAX HOLD ACQUISITION TIME:

dc mode:	180 ms typical
ac mode:	300 ms typical

PEAK HOLD ACQUISITION TIME:

dc mode:	1 ms typical
ac mode:	1 ms typical

ANALOG OUTPUT SCALING:

dc mode:	± 3 Vdc
ac mode:	3 Vrms

ANALOG OUTPUT NOISE: 4 mV rms typical

ANALOG OUTPUT LOAD: 10 kohm min., 100 pF max.

ACCURACY CHANGE WITH TEMPERATURE

(not including probe): ± 0.02 % / °C typical

BATTERY TYPE: 9 Vdc alkaline (NEDA 1640A)

BATTERY LIFE: 8 hours typical (two batteries, analog output and RS-232 port not used)

AUXILIARY POWER: 9 Vdc, 300 mA,

AUXILIARY POWER CONNECTOR: Standard 2.5 mm I.D. / 5.5 mm O.D. connector. Center post is positive (+) polarity.

ANALOG OUTPUT CONNECTOR: BNC

OPERATING TEMPERATURE: 0 to +50°C (+32 to +122°F)

STORAGE TEMPERATURE: -25 to +70°C (-13 to +158°F)

SPECIFICATIONS

METER DIMENSIONS:

Length:	13.2 cm (5.2 in)
Width:	13.5 cm (5.3 in)
Height:	3.8 cm (1.5 in)

WEIGHT:

Meter w/batteries:	400 g (14 oz.)
Shipping:	1.59 kg (3 lb., 8 oz.)

REGULATORY INFORMATION:

Compliance was demonstrated to the following specifications as listed in the official Journal of the European Communities:

EN 50082-1:1992

IEC 801-2:1991
Second Edition
IEC 1000-4-2:1995

ENV 50140:1993
IEC 1000-4-3:1995

Generic Immunity

Electrostatic Discharge
Immunity

Radiated Electromagnetic
Field Immunity

EN 50081-1:1992

EN 55011:1991

Generic Emissions

Radiated and Conducted
Emissions

SPECIFICATIONS

COMMUNICATIONS PORT:

Format:	RS-232C
Lines supported:	Transmit, receive, common.
Connector type:	9-pin "D" female
Cable length:	3 m (9.8 ft.) maximum
Receive input resistance:	3 kohm minimum
Receive voltage limit:	± 30 V maximum
Transmit output voltage:	± 5 V min, ± 8 V typical
Baud rate:	2400
Stop bits:	1
Character length:	8
Parity:	None
Standards supported:	IEEE-1987.2, SCPI-1991

EMC APPLICATION NOTE

Use only high quality, double shielded cables for RS-232 connection. Keep the length of the cables less than 3 meters (9.8 ft.). Long cables (>3m) with insufficient EMI shielding can cause excessive emissions or may be susceptible to external interference.

SPECIFICATIONS

STANDARD TRANSVERSE PROBE

MODEL NUMBER:	STD58-0404
FLUX DENSITY RANGE:	0 to ± 3 T (0 to ± 30 kG)
FREQUENCY BANDWIDTH:	0 - 20 kHz
OFFSET CHANGE WITH TEMPERATURE:	$\pm 30 \mu\text{T}$ (300 mG) / $^{\circ}\text{C}$ typical
ACCURACY CHANGE WITH TEMPERATURE:	- 0.05% / $^{\circ}\text{C}$ typical
OPERATING TEMPERATURE RANGE:	0 to $+75^{\circ}\text{C}$ ($+32$ to $+167^{\circ}\text{F}$)
STORAGE TEMPERATURE RANGE:	-25 to $+75^{\circ}\text{C}$ (-13 to $+167^{\circ}\text{F}$)

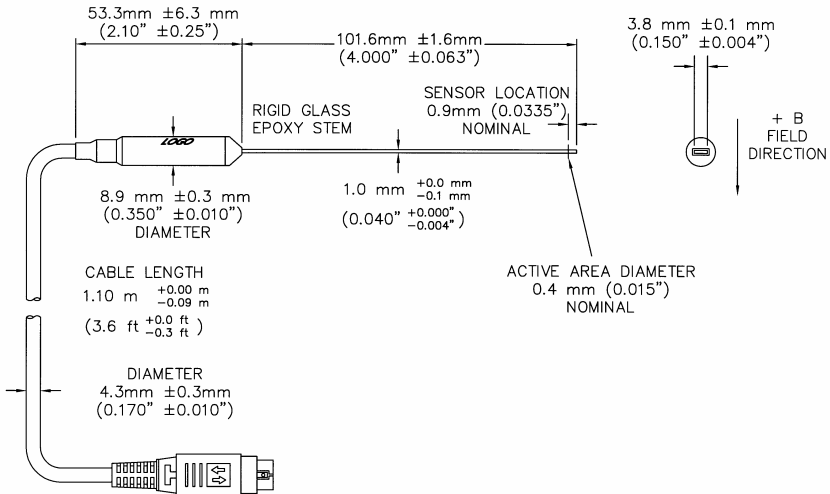

Figure 2-1
Standard Transverse Probe

SPECIFICATIONS

STANDARD AXIAL PROBE

MODEL NUMBER:	SAD58-1904
FLUX DENSITY RANGE:	0 to ± 3 T (0 to ± 30 kG)
FREQUENCY BANDWIDTH:	0 - 20 kHz
OFFSET CHANGE WITH TEMPERATURE:	$\pm 30 \mu\text{T}$ (300 mG) / $^{\circ}\text{C}$ typical
ACCURACY CHANGE WITH TEMPERATURE:	- 0.05% / $^{\circ}\text{C}$ typical
OPERATING TEMPERATURE RANGE:	0 to $+75^{\circ}\text{C}$ ($+32$ to $+167^{\circ}\text{F}$)
STORAGE TEMPERATURE RANGE:	-25 to $+75^{\circ}\text{C}$ (-13 to $+167^{\circ}\text{F}$)

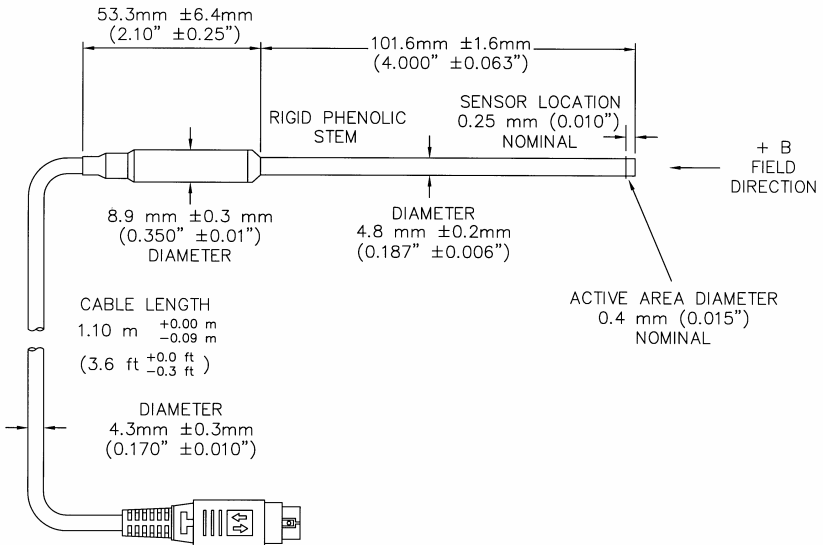

Figure 2-2
Standard Axial Probe

SPECIFICATIONS

OPTIONAL PROBE EXTENSION CABLE

MODEL NUMBER: X5000-0006

OPERATING TEMPERATURE RANGE: 0 to +75°C (+32 to +167°F)

STORAGE TEMPERATURE RANGE: -25 to +75°C (-13 to +167°F)

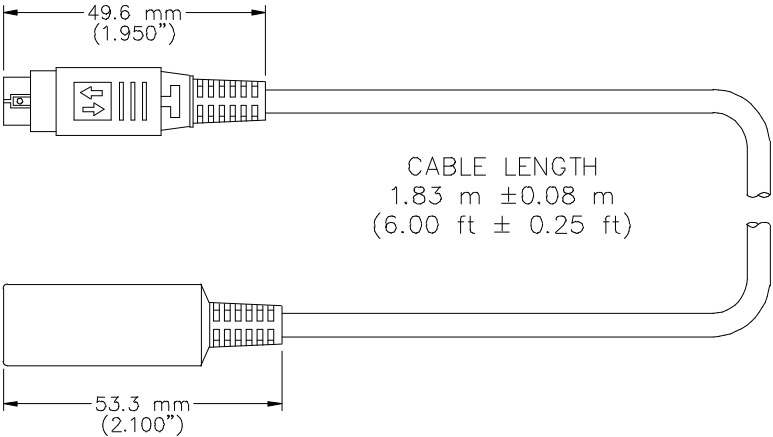

Figure 2-3
Optional Probe Extension Cable

SPECIFICATIONS

ZERO FLUX CHAMBER

MODEL NUMBER: YA-111

CAVITY DIMENSIONS:

Length: 50.8 mm (2")
Diameter: 8.7 mm (0.343")

ATTENUATION: 80 dB to 30 mT (300 G)

PURPOSE: To shield the probe from external magnetic fields during the ZERO or RELATIVE operations.

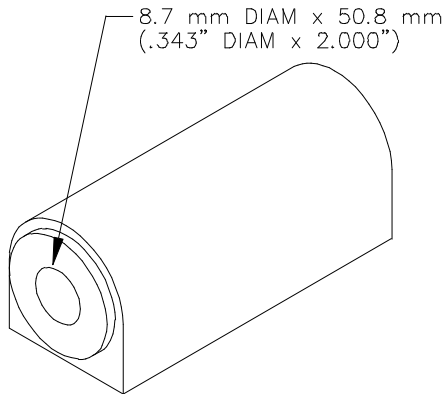

Figure 2-4
Zero Flux Chamber

Section 3

Operating Instructions

OPERATOR SAFETY



Do not connect the auxiliary power connector to an ac power source. Do not exceed 15 Vdc regulated or 9 Vdc unregulated . Do not reverse polarity. Use only a regulated ac-to-dc power supply certified for country of use.

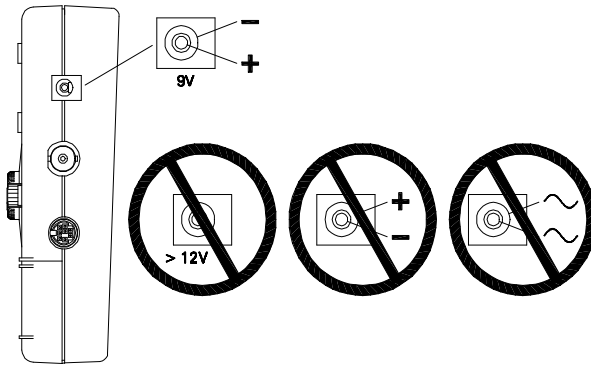

Figure 3-1
Auxiliary Power Connector Warnings

OPERATING INSTRUCTIONS



Do not allow the probe to come in contact with any voltage source greater than 30 Vrms or 60 Vdc.

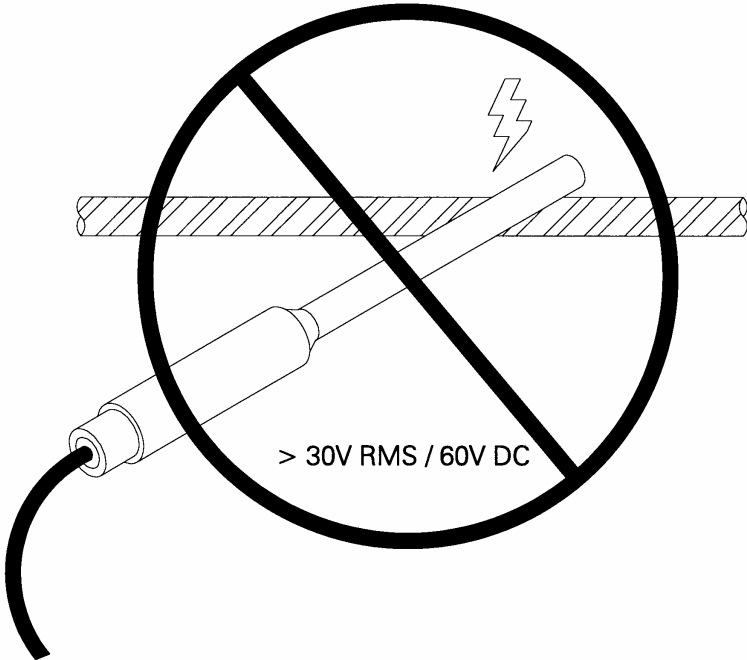

Figure 3-2
Probe Electrical Warning



Batteries contain ferrous materials that are attracted to magnetic fields. Be careful when operating the instrument near large magnetic fields, as it may move without warning. Extension cables are available to increase the probe cable length, so that the instrument can remain in a safe position with respect to the field being measured with the probe.

OPERATING INSTRUCTIONS

OPERATING FEATURES

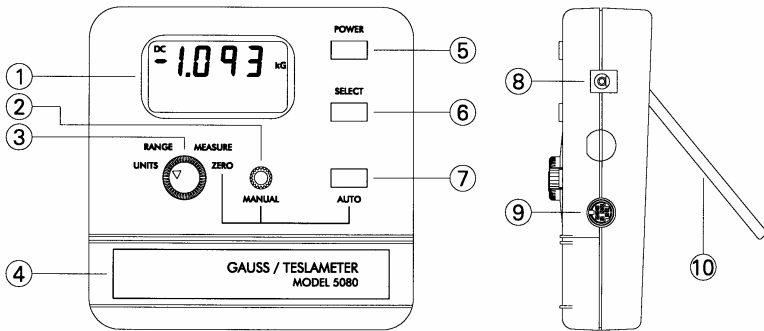

Figure 3-3
Operating Features

- ① **Display.** Liquid crystal display (LCD).
- ② **Manual ZERO / RELATIVE Control.** In the ZERO and RELATIVE modes of operation the user can manually adjust the zero or relative point using this control.
- ③ **Function Selector.** This control allows the operator to change the meter's range, units of measure, ac or dc measurement, hold modes and operation of the analog output. It also engages the ZERO, RELATIVE and MEASURE modes of operation.
- ④ **RS-232 Port.** Shielded 9-pin "D" connector supporting RS-232-C serial communications.

OPERATING INSTRUCTIONS

- 5 **Battery Compartment Cover.** This cover slides open to allow one or two 9 volt batteries to be installed.

- 6 **Power Switch.** Push-on / push-off type switch to apply power to the meter.

- 7 **SELECT Switch.** Momentary pushbutton used in conjunction with the Function Selector (3) to configure the meter's range, units of measure, ac or dc measurement, hold modes and operation of the analog output.

- 8 **AUTO/HOLD RESET Switch.** Momentary pushbutton used to reset the held reading when one of the HOLD modes is being used, or to start an automatic ZERO or RELATIVE operation when in the ZERO or RELATIVE modes.

- 9 **Auxiliary Power Connector.** This is an industry standard 2.5 mm I.D. / 5.5 mm O.D. dc power connector. The meter will accept a regulated dc voltage in the range of 6 - 15 Vdc at 300 mA minimum current or unregulated 9 Vdc. The center pin is positive (+). The internal batteries are disconnected when using this connector.



Do not connect the auxiliary power connector to an ac power source. Do not exceed 15 Vdc regulated or 9 Vdc unregulated. Do not reverse polarity. Use only a regulated ac-to-dc power supply certified for country of use.

OPERATING INSTRUCTIONS

- ⑩ **Analog Output Connector.** A voltage signal representative of the magnetic flux density being measured is available at this BNC connector. Calibration is set to ± 3.0 V full scale dc or 3.0 Vrms ac, depending upon the mode of operation . Minimum load is 10 kohm. The analog output will be active when the ANALOG ON/OFF function has been turned ON using the Function Selector ③ .
- ⑪ **Probe Connector.** The Hall probe or probe extension cable plugs into this connector and locks in place. To disconnect, pull on the body of the plug, *not the cable* !
- ⑫ **Meter Stand.** Retractable stand that allows the meter to stand upright when placed on a flat surface. A notch in the stand allows the meter to be mounted to a vertical surface.

OPERATING INSTRUCTIONS

INSTRUMENT PREPARATION

1) With the power switch turned off (POWER pushbutton in the full up position) apply pressure to the battery compartment cover at the two points shown in Figure 3-4. Slide the cover open and remove.

2) Install one or two 9 volt alkaline batteries (two batteries will provide longer operating life). The battery compartment is designed so that the battery polarity cannot be reversed. Reinstall the battery compartment cover.

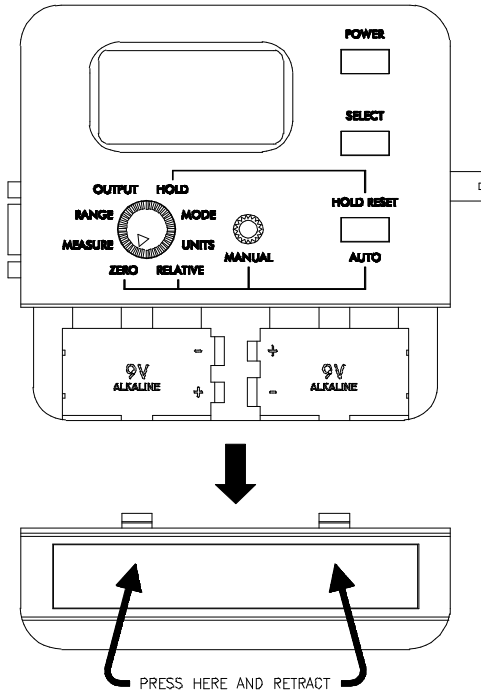

Figure 3-4
Battery Installation

OPERATING INSTRUCTIONS

- 3) If using an ac-to-dc power supply review Figure 3-1 for safety notes and the *SPECIFICATIONS* section for voltage and current ratings. When using a power supply the batteries are automatically disconnected.
- 4) Install the probe or probe extension cable by matching the key in the connector to that in the mating socket in the meter. The connector will lock in place. To disconnect, pull on the body of the plug, *not the cable!*

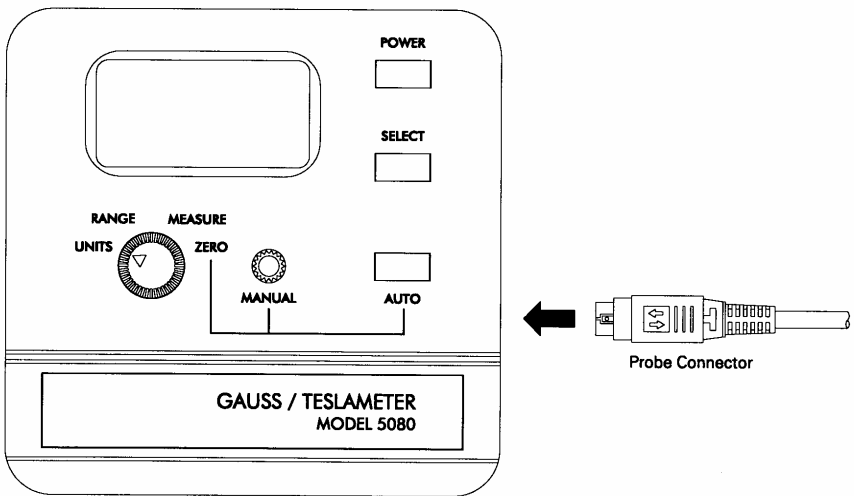

Figure 3-5
Probe Connection

OPERATING INSTRUCTIONS

POWER-UP

Depress the POWER switch. There will be a momentary audible beep and all display segments will appear on the display.

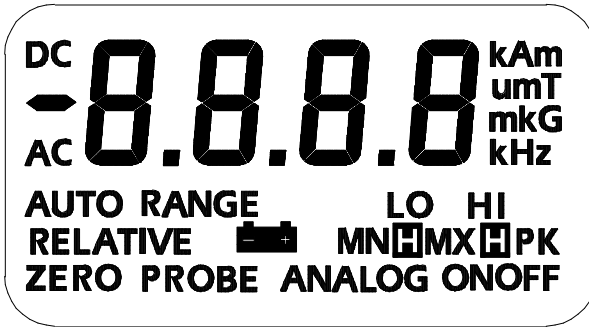

Figure 3-6
Power-Up Display

The instrument will conduct a self test before measurements begin. If a problem is detected the phrase “Err” will appear on the display followed by a 3-digit code. The circuitry that failed will be retested and the error code will appear after each failure. This process will continue indefinitely or until the circuitry passes the test. A condition in which a circuit fails and then passes should not be ignored because it indicates an intermittent problem that should be corrected.

If the self test is successful the meter will perform a self calibration. During this phase the meter will display the software revision number, such as “r 1.0”. Calibration will halt if there is no Hall probe connected. Until the probe is connected the phrase “Err” will appear accompanied by a flashing “PROBE” annunciator as shown in Figure 3-7.

OPERATING INSTRUCTIONS

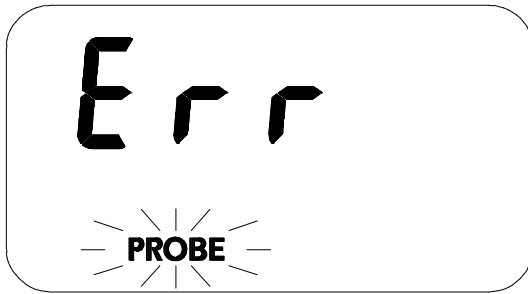

Figure 3-7
Missing Probe Indication

After power-up the position of the FUNCTION selector switch will determine what happens next. For instance if the selector is in the RANGE position the meter will wait for the user to change the present range. If in the MEASURE position flux density measurements will begin.

Allow adequate time for the meter and probe to reach a stable temperature. See the *SPECIFICATIONS* section for specific information.

POWER-UP SETTINGS

The meter permanently saves certain aspects of the instrument's setup and restores them the next time the meter is turned on. The conditions that are saved are:

- RANGE setting (including AUTO range)
- MODE (ac or dc)
- UNITS of measure (gauss, tesla or ampere-meter)
- HOLD mode (min, max or peak)

OPERATING INSTRUCTIONS

Other aspects are not saved and default to these conditions:

RELATIVE mode (turned OFF)

RELATIVE value (set to 0)

ZERO mode (inactive)

OUTPUT function (turned OFF and output set to 0 Vdc)

NOTE: The present setup of the instrument is saved only when the FUNCTION selector is returned to the MEASURE position. For example assume the meter is in the MEASURE mode on the 30 mT range. The FUNCTION selector is now turned to the RANGE position and the 300 mT range is selected. The meter is turned off and on again. The meter will be restored to the 30 mT range because the FUNCTION selector was never returned to the MEASURE mode prior to turning it off.

LOW BATTERY CONDITION

The meter is designed to use one or two standard 9V alkaline batteries (two batteries will provide longer operating life). When the battery voltage becomes too low the battery symbol on the display will flash, as shown in Figure 3-8. Replace the batteries or use an external ac-to-dc power supply.



Instrument specifications are not guaranteed when a low battery condition exists !

OPERATING INSTRUCTIONS

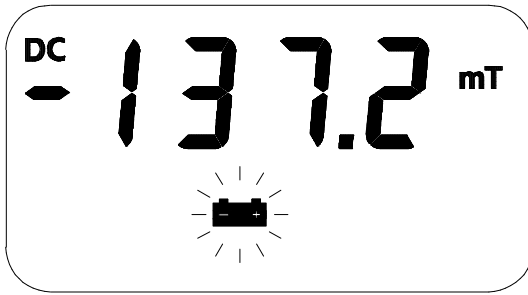

Figure 3-8
Low Battery Indication

OVERRANGE CONDITION

If the magnitude of the magnetic flux density exceeds the limit of the selected range the meter will display a flashing value of “2999” (gauss or tesla mode) or “2387” (ampere-meter mode). The next highest range should be selected. If already on the highest range then the flux density is too great to be measured with this instrument.



Figure 3-9
Overrange Indication

OPERATING INSTRUCTIONS

AC OR DC MEASUREMENT SELECTION

The meter is capable of measuring either static (dc) or alternating (ac) magnetic fields. To choose the desired mode rotate the function selector to the MODE setting, then press the SELECT pushbutton to select AC or DC on the display.

The dc and ac modes is discussed in more detail later in this section.

This setting is saved and will be restored the next time the meter is turned on.

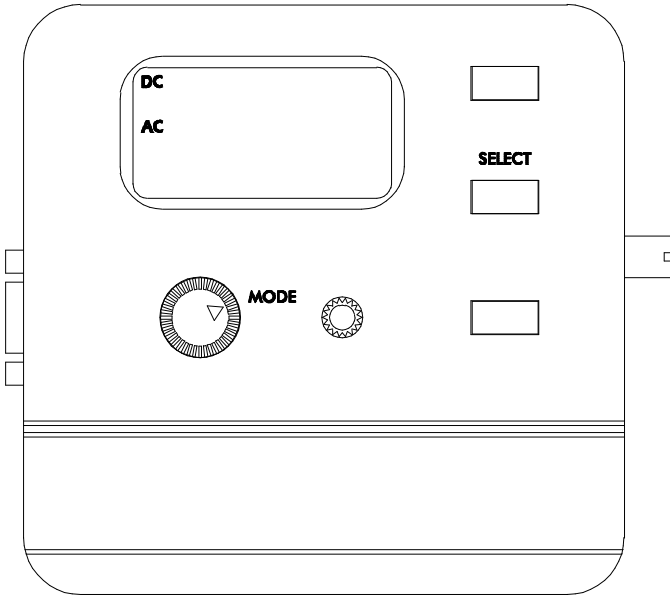

Figure 3-10
MODE (AC-DC) Function

OPERATING INSTRUCTIONS

UNITS OF MEASUREMENT SELECTION

The meter is capable of providing flux density measurements in terms of gauss (G), tesla (T) or ampere-meters (Am). To choose the desired units, rotate the function selector to the UNITS position. Press the SELECT pushbutton to select G, T or Am on the display.

This setting is saved and will be restored the next time the meter is turned on.

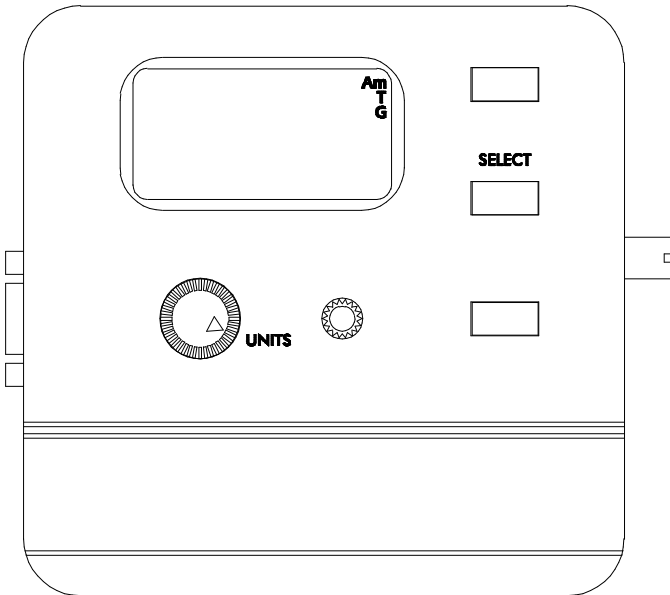

Figure 3-11
UNITS Function

OPERATING INSTRUCTIONS

RANGE SELECTION

The meter is capable of providing flux density measurements on one of three fixed ranges, or it can be programmed to automatically select the best range for the present flux density. The available ranges are listed in the *SPECIFICATIONS* section of this manual. The ranges advance in decade steps. The lowest range offers the best resolution while the highest range allows higher flux levels to be measured.

In the AUTO range mode the range is advanced if the reading reaches the full scale of the present range. This is 2999 if in the gauss or tesla mode (such as 299.9 G or 299.9 mT), or 2387 if in the ampere-meter mode (such as 23.87 kAm). The range is lowered if the present reading falls below 10% of full scale for the present range. The speed at which the readings are updated decreases slightly when AUTO ranging is used.

NOTE: The AUTO range selection will be canceled if the RELATIVE mode is turned on.

To choose the desired range rotate the function selector to the RANGE position. The "RANGE" legend will flash. Press the SELECT pushbutton to select the desired range or AUTO RANGE on the display.

This setting is saved and will be restored the next time the meter is turned on.

OPERATING INSTRUCTIONS

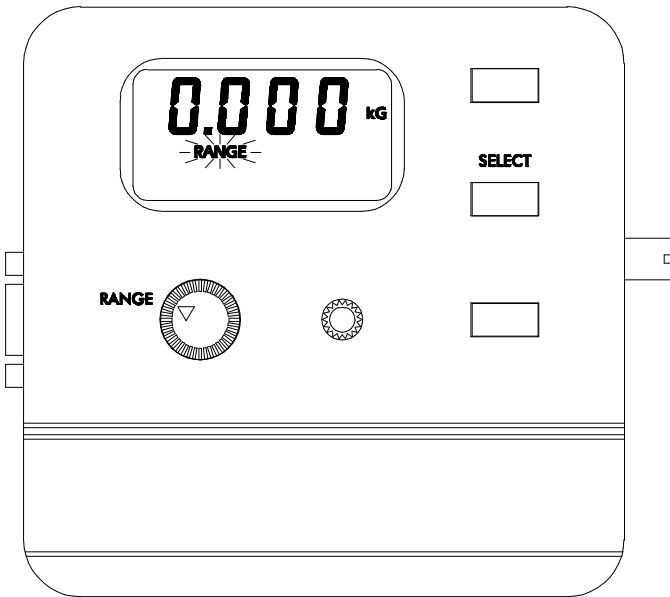

Figure 3-12
RANGE Function

OPERATING INSTRUCTIONS

HOLD MODE SELECTION

In some applications it may be desirable to hold a reading that is either greater than or less than all previous readings, or which has the greatest peak value whether positive or negative.

The MAX HOLD function holds the reading that is arithmetically greater than all previous readings. For instance a reading of +125.0 is greater than +99.0 or -150.0.

The MIN HOLD function holds the reading that is arithmetically less than all previous readings. For instance a reading of -125.0 is less than -99.0 or +150.0.

The PEAK HOLD function captures and holds the peak value of the flux density waveform within the response time capabilities of the meter. See the *SPECIFICATIONS* section of this manual for more information. The peak can be either positive or negative, whichever has the greatest magnitude. For instance a peak value of -100.0 is greater than a peak value of +90.0.

To choose the desired hold mode rotate the function selector to the HOLD position. Press the SELECT pushbutton to select the desired mode on the display. MAX HOLD is indicated by "MX". MIN HOLD is indicated by "MN". PEAK HOLD is indicated by "PK". The "OFF" legend will appear when all HOLD modes are turned off.

This setting is saved and will be restored the next time the meter is turned on.

OPERATING INSTRUCTIONS

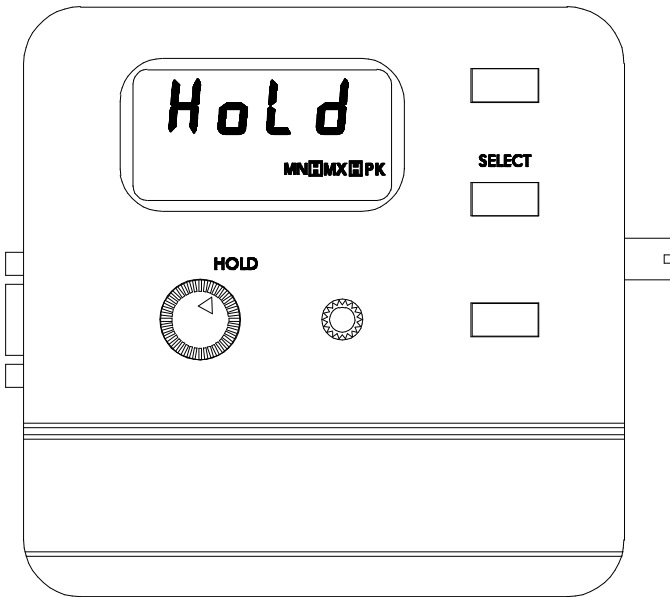

Figure 3-13
HOLD Function

MIN / MAX HOLD USAGE

See the *SPECIFICATIONS* section for response time information.

The MAX HOLD function holds the reading that is arithmetically greater than all previous readings. The MIN HOLD function holds the reading that is arithmetically less than all previous readings. These modes are useful in determining the maximum or minimum value of magnetic events that occur over a period of time.

The MIN or MAX HOLD operation begins when the function selector is returned to the MEASURE position. If the reading exceeds the range limit the meter will hold a flashing value of

OPERATING INSTRUCTIONS

“2999” (gauss or tesla mode), “2387” (ampere-meter mode) or the maximum value allowed in the RELATIVE mode.

The held value can be reset by pressing the HOLD RESET pushbutton. The next value displayed after a reset will be the present value of flux density. For instance if the held reading is 200.0 G and the present flux density is -100.0 G, the meter will display -100.0 G after the reset.

If the analog output is being used the output signal will continue to represent the real time flux density as seen by the probe. It is not affected by the HOLD function.

PEAK HOLD USAGE

See the *SPECIFICATIONS* section for response time and accuracy information.

In the PEAK HOLD mode the input signal is sampled many times each second. Each sample is compared to all previous samples and that which has the greatest amplitude (regardless of polarity) is held on the display. This mode can be used to capture the peak value of a fast, one-time magnetic event such as a magnetizing pulse.

The PEAK HOLD operation begins when the function selector is returned to the MEASURE position. If the reading exceeds the range limit the meter will hold a flashing value of “2999” (gauss or tesla mode), “2387” (ampere-meter mode) or the maximum value allowed in the RELATIVE mode. The held value can be reset by pressing the HOLD RESET pushbutton.

These are the differences between the PEAK HOLD mode and the MIN / MAX HOLD modes:

OPERATING INSTRUCTIONS

- The PEAK HOLD mode considers only the magnitude of the reading and not the polarity.
- The response time of the PEAK HOLD mode is much faster but final accuracy is less.

If the analog output is being used the output signal will continue to represent the real time flux density as seen by the probe. It is not affected by the HOLD function.

OPERATING INSTRUCTIONS

ZERO FUNCTION

“Zeroing” the probe and meter is one of the most important steps to obtaining accurate dc flux density measurements. The ideal Hall generator produces zero output in the absence of a magnetic field, but actual devices are subject to variations in materials, construction and temperature. Therefore most Hall generators produce some output even in a zero field. This will be interpreted by the meter as a flux density signal.

Also, the circuits within the meter can produce a signal even when there is no signal present at the input. This will be interpreted as a flux density signal. Lastly magnetic sources close to the actual field being measured, such as those from electric motors, permanent magnets and the earth (roughly 0.5 gauss or 50 μT), can induce errors in the final reading.

It is vital to remove these sources of error prior to making actual measurements. The process of “zeroing” removes all of these errors in one operation. The meter cancels the combined dc error signal by introducing another signal of equal magnitude with opposite polarity. After zeroing the only dc signal that remains is that produced by the probe when exposed to magnetic flux.

NOTE: Zeroing the meter and probe affects only the static (dc) component of the flux density signal.

NOTE: The process of zeroing also affects the analog signal.

There may be situations when the user prefers to shield the probe from all external magnetic fields prior to zeroing. Provided with the meter is a ZERO FLUX CHAMBER which is capable of shielding against fields as high as 30 mT (300 G or 23.88 kAm). The probe is simply inserted into the chamber before the zeroing process begins.

OPERATING INSTRUCTIONS



Handle the Hall probe with care. Do not bend the stem or apply pressure to the probe tip as damage may result.

In other situations the user may want the probe to be exposed to a specific magnetic field during the zeroing process so that all future readings do not include that reading (such as the earth's field). This is possible with the following restrictions:

- 1) The external field must not exceed 30 mT (300 G or 23.88 kAm).
- 2) The field must be stable during the zeroing process. It should not contain alternating (ac) components.

AUTOMATIC ZERO FUNCTION

The meter provides two methods to zero the probe. The first is completely automatic. Prepare the probe for zeroing, then rotate the function selector to the ZERO position. The "ZERO" legend will flash and actual dc flux density readings will appear on the display. The meter will select the lowest range regardless of which range was in use prior to using the ZERO function. Recall that the maximum flux density level that can be zeroed is 30 mT (300 G or 23.88 kAm). If the existing field is too large consider using the RELATIVE mode (discussed later in this section). The meter will switch over to the dc mode of operation during zeroing. Recall that the zeroing operation affects dc errors only. If you wish to suppress an ac field consider using the RELATIVE mode.

OPERATING INSTRUCTIONS

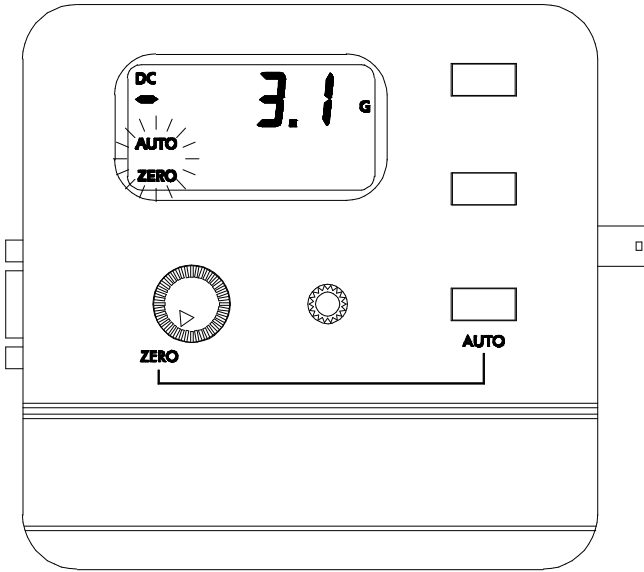

Figure 3-14
Automatic ZERO Function

Press the AUTO pushbutton and the process will begin. The “AUTO” legend will also flash. Once automatic zeroing begins it must be allowed to complete. During this time all controls are disabled except for the POWER switch. The process normally takes from 5 to 15 seconds.

The meter selects the lowest range and adjusts the nulling signal until the net result reaches zero. If the existing field is too large or unstable the meter will sound a double beep and the phrase “OVER” will appear momentarily on the display. At this point the automatic process is terminated and the flashing “AUTO” legend will disappear. The “ZERO” legend will continue to flash to remind the user that the ZERO mode is still active.

OPERATING INSTRUCTIONS

If the nulling process is successful, the next highest range is selected. No further electronic adjustments are made, but at this stage a reading is acquired which will be mathematically subtracted from all future readings on this range. This process is then repeated for the highest range. When finished, the meter will sound an audible beep and the flashing "AUTO" legend will disappear. The "ZERO" legend will continue to flash to remind the user that the ZERO mode is still active. At this point the automatic process can be repeated or a manual adjustment can be performed (see "Manual Zeroing").

The final zero values will remain in effect until the meter and probe are zeroed again, if the probe is disconnected or if the meter is turned off and back on again.

NOTE: Zeroing the probe cancels the RELATIVE mode if it was turned on.

MANUAL ZERO FUNCTION

The second zeroing method is a manual adjustment. This feature also allows the user to set the "zero" point to something other than zero, if desired. Position the probe for zeroing, then rotate the function selector to the ZERO position. The "ZERO" legend will flash and actual dc flux density readings will appear on the display. The meter will select the lowest range regardless of which range was in use prior to selecting the ZERO function. Recall that the maximum flux density level that can be zeroed is 30 mT (300 G or 23.88 kAm). If the existing field is too large, consider using the RELATIVE mode (discussed later in this section). The meter will switch over to the dc mode of operation during zeroing. Recall that the zeroing operation affects dc errors only. If you wish to suppress an ac field consider using the RELATIVE mode.

OPERATING INSTRUCTIONS

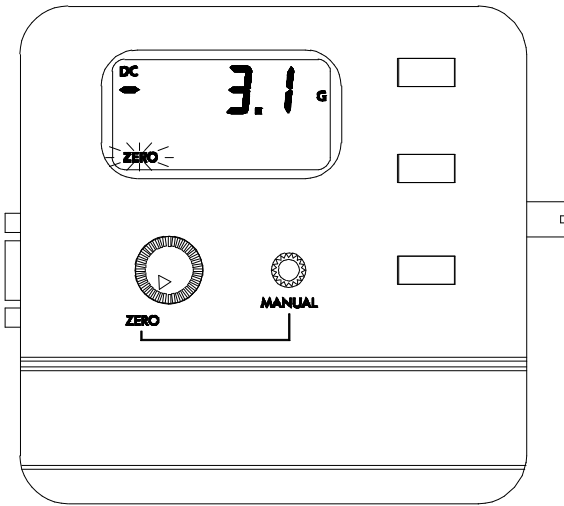

Figure 3-15
Manual ZERO Function

By turning the MANUAL control in either direction the reading will be altered. Turning the control clockwise adds to the reading, turning it counterclockwise subtracts from the reading. Turning it slowly results in a fine adjustment, turning it quickly results in a coarse adjustment.

NOTE: Making a manual ZERO adjustment not only affects the lowest range but also the higher ranges, though to a lesser extent. For example, assume an automatic ZERO has already been performed, after which all three ranges should read zero. Now a manual adjustment is made that causes the reading on the lowest range to be non-zero. The reading on the other ranges may also be non-zero depending upon the magnitude of the change. The adjustment has 10 times less effect on the middle range and 100 times less effect on the highest range.

OPERATING INSTRUCTIONS

NOTE: Zeroing the probe cancels the RELATIVE mode if it was turned on.

RELATIVE MODE

The RELATIVE mode allows a specific flux density value to be subtracted from all future readings. Thus all future readings will be “relative” to that value. For instance if the relative value is +100.0 gauss, and the present flux density is +112.0 gauss, the actual displayed value will be +12.0 gauss. If the flux density drops to +77.0 gauss, the actual displayed value will be -23.0. Thus the RELATIVE mode allows for the direct readout of variations around a given field, whether static (dc) or alternating (ac).

There are two ways to generate a relative value. In the automatic mode the meter uses the present flux density reading from the probe as the relative value. In the manual mode, the user can specify a value using the MANUAL control. Each mode will be discussed in more detail.

There are three restrictions when using the RELATIVE mode:

- 1) The RELATIVE mode can only be used on a fixed range. If the AUTO range feature is in use and then the RELATIVE mode is turned on the AUTO range feature is canceled. Conversely, if the RELATIVE mode is turned on and then the AUTO range feature is turned on, the RELATIVE mode is canceled.
- 2) If the RELATIVE mode has been turned ON and the probe is zeroed via the ZERO function, the RELATIVE mode is canceled.
- 3) The point at which the meter declares an OVERRANGE condition changes when using the RELATIVE mode. Normally

OPERATING INSTRUCTIONS

an overrange occurs when the reading reaches the full scale limit of ± 2999 in the gauss or tesla mode (such as ± 299.9 G, ± 29.99 mT, etc.) or ± 2387 if in the ampere-meter mode (such as 23.87 kAm). At that point the digits will remain at “2999” or “2387” and will flash to indicate an overrange condition (see Figure 3.9).

In the RELATIVE mode this limit can be exceeded by about 35% to a maximum value of ± 4095 as seen by the probe.

To clarify this, suppose the meter is set to the 300 mT range and the probe is in a +350.0 mT field. Under normal conditions this would have resulted in an overrange condition (a flashing reading of +299.9 mT). Now the RELATIVE mode is turned on with an initial relative value of 0. In this mode the meter is able to measure flux density up to ± 409.5 mT. A non-flashing reading of +350.0 mT will now appear on the display.

Now the probe is inserted into the zero flux chamber and a relative value is set to +200.0 mT. The probe is now inserted back into the original +350.0 mT field. The displayed value will now be +150.0 mT ($+350.0 - 200.0 = +150.0$). The field then increases to +420.0 mT. This is an overrange condition because the limit of 409.5 mT (as seen by the probe) has been exceeded. A flashing reading of +209.5 will appear on the display to indicate an overrange condition ($+409.5 - 200.0 = +209.5$).

There may be situations when the user may prefer to shield the probe from all external magnetic fields prior to performing a RELATIVE operation. Provided with the meter is a ZERO FLUX CHAMBER which is capable of shielding against fields as high as 30 mT (300 G or 23.88 kAm). The probe is simply inserted into the chamber before the RELATIVE operation begins.

OPERATING INSTRUCTIONS



Handle the Hall probe with care. Do not bend the stem or apply pressure to the probe tip as damage may result.

To activate or deactivate the RELATIVE mode rotate the function selector to the RELATIVE position. The RELATIVE legend will flash and actual flux density readings will appear on the display. Press the SELECT pushbutton to turn the mode ON or OFF. Then set the relative point using either the automatic or manual mode.

NOTE: The RELATIVE mode is canceled if the probe and meter are zeroed, if the probe is disconnected, if the meter's range is changed or if the meter is turned off and back on again.

NOTE: If the analog output is being used the output signal will continue to represent the flux density as seen by the probe. It is not affected by the RELATIVE operation.

OPERATING INSTRUCTIONS

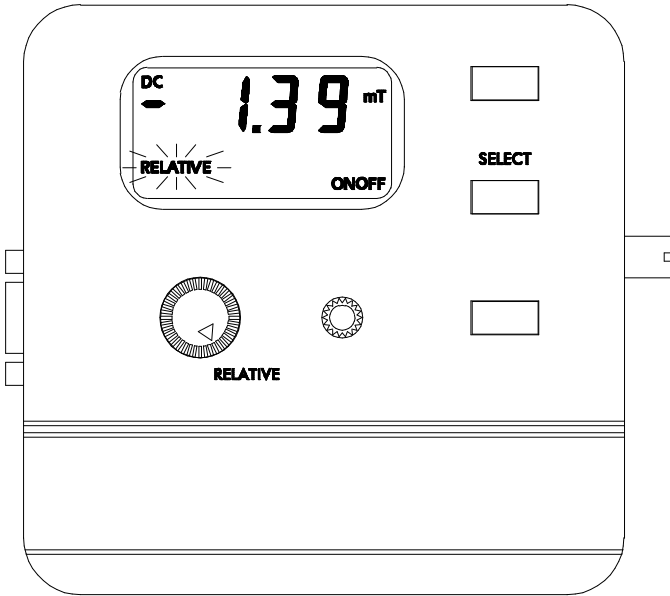

Figure 3-16
RELATIVE Function

AUTOMATIC RELATIVE MODE

In the automatic mode, the present flux density as seen by the probe is used as the relative value. Prepare the probe and select an appropriate range and mode (ac or dc) as needed (AUTO range is deactivated when RELATIVE mode is used).

OPERATING INSTRUCTIONS

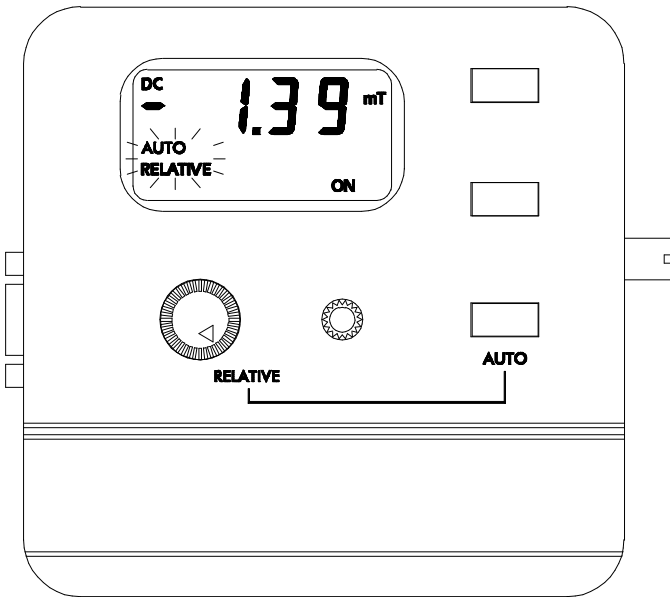

Figure 3-17
Automatic RELATIVE Function

Press the AUTO pushbutton. The “AUTO” legend will flash for a moment and a reading will be acquired. This now becomes the new relative value. The meter will sound a single beep and the “AUTO” legend will disappear. The reading should now be zero. From this point the relative value will be subtracted from all future readings. The “RELATIVE” legend will continue to flash to remind the user that the RELATIVE mode is still active. At this point, the automatic process can be repeated, or a manual adjustment can be made (see “Manual Relative Mode”). When returning to the MEASURE mode, the “RELATIVE” legend will remain on to remind the user that the displayed value is a relative value, not an absolute value.

OPERATING INSTRUCTIONS

MANUAL RELATIVE MODE

The second method by which to set a relative value is a manual adjustment. In some cases the user will wish to set an absolute relative value. To do this, insert the probe in the ZERO FLUX CHAMBER provided with the meter.



Handle the Hall probe with care. Do not bend the stem or apply pressure to the probe tip as damage may result.

At this point the “RELATIVE” legend will be flashing and actual flux density readings will be displayed. By turning the MANUAL control in either direction the reading will be altered. Turning the control clockwise adds to the reading, turning it counterclockwise subtracts from the reading. Turning it slowly results in a fine adjustment. Turning it quickly results in a coarse adjustment. Once the desired relative value has been reached, the probe can be removed from the ZERO FLUX CHAMBER and measurements can begin. The final relative value will be subtracted from all future readings.

In other cases, the probe may be positioned in a stable dc or ac magnetic field that does not exceed the present range limit (see the prior discussion on overrange conditions in the RELATIVE mode). In most cases the reading will be adjusted to zero so that the value of the reference is subtracted from all future readings.

OPERATING INSTRUCTIONS

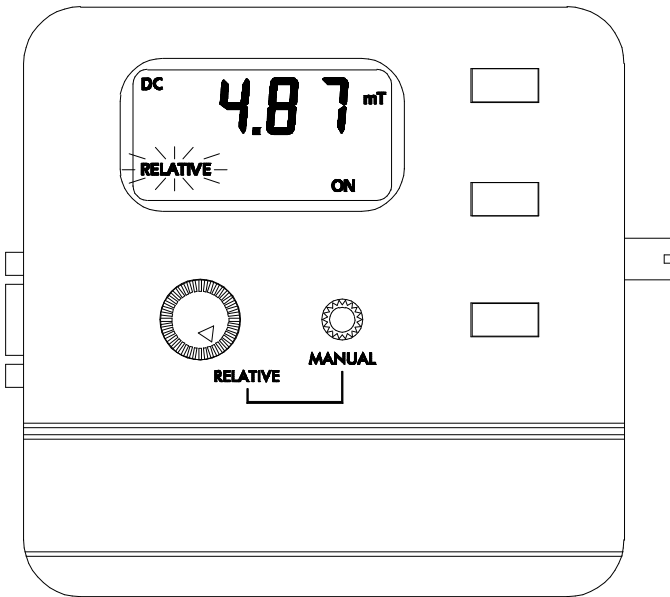

Figure 3-18
Manual RELATIVE Function

ANALOG OUTPUT FUNCTION

The meter is capable of providing an analog voltage signal proportional to the present flux density level. Calibration is set to ± 3.0 V full scale dc or 3.0 Vrms ac, depending upon the mode of operation. This signal, available at the BNC connector, can be connected to a voltmeter, oscilloscope, recorder or external analog-to-digital converter.

Power consumption increases when using the analog output. For this reason the analog output is set to zero volts upon power-up and the analog function is turned OFF. To activate or deactivate the output, rotate the function selector to the OUTPUT position, then press the SELECT pushbutton to select the desired setting.

OPERATING INSTRUCTIONS

There are two modes of operation that affect the upper frequency limit of the output signal (see Figure 3-19). The LO setting has an upper frequency limit of 1 kHz. When returning to the MEASURE mode the user will be provided with both an analog output signal and flux density readings on the display. The use of the LO mode will reduce the rate at which the display is updated with new readings.

The HI setting has an upper frequency limit of 20 kHz. When returning to the MEASURE mode the user will be provided only with an analog output signal. In this mode the only legends that will appear will be “ANALOG ON” and “HI” (see Figure 3-20).

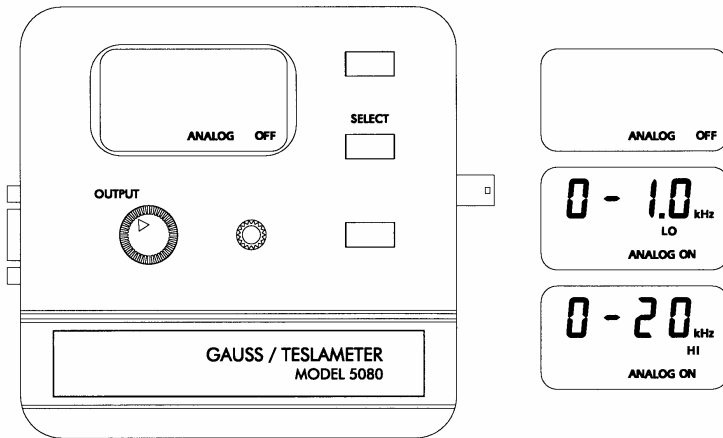

Figure 3-19
OUTPUT Function

OPERATING INSTRUCTIONS

ANALOG OUTPUT USAGE

See the *SPECIFICATIONS* section for frequency range and accuracy of the analog output.

The analog output signal is calibrated to ± 3 Vdc or 3 Vrms, depending upon the selected mode. For instance on the 30 mT range a reading of -12.3 mT relates to a output voltage of -1.23 Vdc whereas on the 3 T range a reading of -1.23 T produces the same output. The analog output can reach a maximum output of about ± 4.25 Vdc in order to accommodate the peak value of a 3 Vrms ac signal. This means that the analog output can be used to measure flux density levels that exceed the normal range of the displayed readings. For instance a level of 36.5 mT on the 30 mT range would normally result in a flashing "29.99" mT overrange condition, but the output will still be +3.65 Vdc.

There are two modes of operation that affect the upper frequency limit of the output signal. The LO setting provides the user with flux density readings on the display or from the communications port as well as an analog output signal from the output connector. The use of the LO mode will reduce the rate at which the display is updated with new readings. The LO setting is usable at frequencies from 0 - 1 kHz.

In the HI setting the display is disabled, showing only the "ANALOG ON" and "HI" legends (see Figure 3-20). Only an analog output signal is available in this mode but the accuracy of this signal is much better at higher frequencies.

OPERATING INSTRUCTIONS

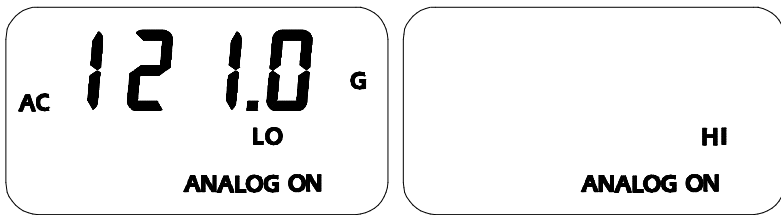

Figure 3-20
LO and HI Analog Output Displays

When using the AUTO range and the analog output features together the following situation can occur. Suppose the present range is 3 kG and the present reading is +2.8 kG. The analog output will be +2.8 Vdc. The signal then increases to +3.2 kG, which would force an automatic change to the 30 kG range setting. The analog output will now be +0.32 Vdc because of the range change. This can lead to problems if the analog signal is being used to make decisions because there is no indication that a range change has occurred. In these situations it is best to select a fixed range that covers the expected flux density span.

The analog output will be set to 0 Vdc whenever the FUNCTION selector is turned to the RANGE, HOLD, MODE, UNITS or OUTPUT position.

The analog output signal contains both the dc and ac components of the flux density signal. This means that it will also contain any initial dc offsets in the probe and the meter's circuitry. These offsets can be removed by the ZERO function.

The ZERO function can also be used to introduce a dc offset if desired. This is useful when observing ac waveforms in which one portion of the waveform is being clipped because it exceeds the ± 4.25 Vdc limit of the meter. Using the ZERO function the

OPERATING INSTRUCTIONS

center of the waveform can be moved to reduce or eliminate the clipping, as depicted in the next figure.

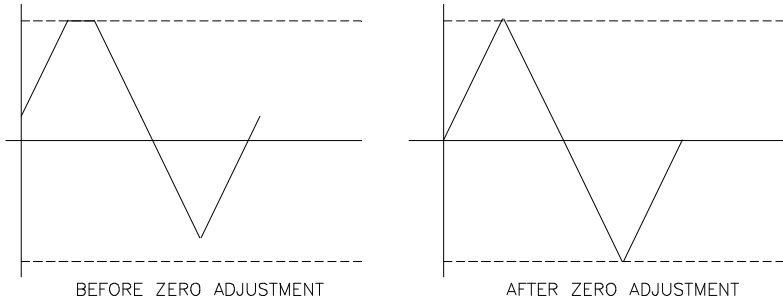

Figure 3-21
Adjusting the DC Offset of the Analog Output

SOURCES OF MEASUREMENT ERRORS

When making flux density measurements there are several conditions that can introduce errors:

- 1) Operating the meter while the LOW BATTERY symbol appears.



Instrument specifications are not guaranteed when a low battery condition exists !

- 2) Failure to zero the error signals from the meter, probe and nearby sources of magnetic interference.

OPERATING INSTRUCTIONS

3) Subjecting the probe to physical abuse.



Handle the Hall probe with care. Do not bend the stem or apply pressure to the probe tip as damage may result. Use the protective cover when the probe is not in use.

4) One of the most common sources of error is the angular position of the probe with respect to the field being measured. As mentioned in Section-1, a Hall generator is not only sensitive to the number of flux lines passing through it but also the *angle* at which they pass through it. The Hall generator produces the greatest signal when the flux lines are perpendicular to the sensor as shown in Figure 3-22.

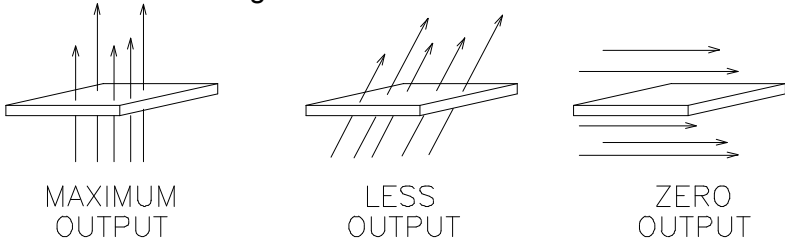

Figure 3-22
Probe Output versus Flux Angle



The probe is calibrated and specified with flux lines passing perpendicularly through the Hall generator.

5) As shown in Figure 3-23 the greater the distance between the magnetic source and the Hall probe the fewer flux lines will pass through the probe, causing the probe's output to decrease.

OPERATING INSTRUCTIONS

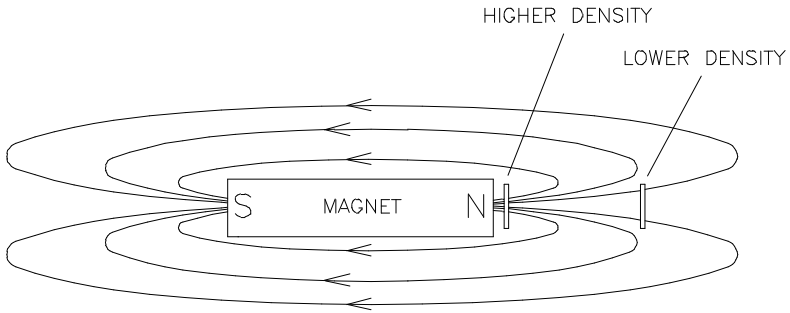

Figure 3-23
Probe Output versus Distance

6) Flux density can vary considerably across the pole face of a permanent magnet. This can be caused by internal physical flaws such as hairline cracks or bubbles, or an inconsistent mix of materials. Generally the sensitive area of a Hall generator is much smaller than the surface area of the magnet, so the flux density variations are very apparent. Figure 3-24 illustrates this situation.

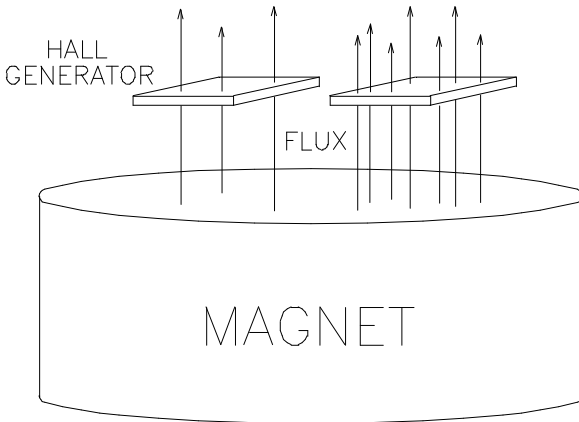

Figure 3-24
Flux Density Variations in a Magnet

OPERATING INSTRUCTIONS

7) Using more than one extension cable can result in measurement errors. In some cases the meter may report an error. Total cable length between the meter and the probe connector should not exceed 2.1 m (7 ft).



The use of more than one extension cable can result in measurement errors and increase susceptibility to radio frequency interference (RFI).

8) The accuracies of the meter and probe are effected by temperature variations. Refer to the *SPECIFICATIONS* section for specific information.

MORE DETAILS ON AC MODE OPERATION

It is possible for the flux density signal to contain both a dc component and an ac component. In the ac mode the value displayed is the true rms value of the waveform with its dc component removed. However if the dc component is too high it may force the peak value of the waveform to exceed the electrical limits of the meter, causing the waveform to clip and introducing errors in the final reading. This can also lead to an overrange condition on the display and can lead to erratic behavior if the AUTO range feature is being used. The presence of a clipped ac signal can be verified by observing the analog output signal.

As stated in the *SPECIFICATIONS* section the accuracy of the true rms reading is only guaranteed for readings greater than about 3.3% of the full scale range. For example this would be 1mT on the 300 mT range. When the reading falls below 3.3% of full scale the "AC" legend on the display will flash, as shown in

OPERATING INSTRUCTIONS

Figure 3-25. This is intended to remind the user that the reading may not be accurate. Select a lower range if possible to regain accuracy.

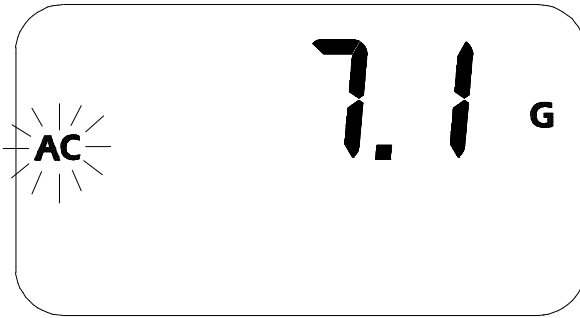

Figure 3-25
Low AC Signal Indication

An ac reading, being a true rms value, has no polarity. However when using the RELATIVE function in the ac mode readings can be negative. A negative ac reading means that the present reading is less than the RELATIVE value. An unsigned value means the present reading is greater than or equal to the RELATIVE value. For example if the original RELATIVE value was 100 mT and the present field is 80 mT the result will be -20 mT.

When using the MIN HOLD function without the RELATIVE function turned on the minimum reading will be 0.0. With the RELATIVE function turned on the minimum reading can reach the negative full scale limit of the meter.

OPERATING INSTRUCTIONS

MORE DETAILS ON DC MODE OPERATION

It is possible for the flux density signal to contain both a dc component and an ac component. In the dc mode this can lead to instable readings. If the peak value of the ac component reaches the electrical limits of the meter, even though the average dc level is within the limits, an overrange condition may appear on the display. This situation can also lead to erratic behavior if the AUTO range feature is being used.

The presence of an ac signal can be verified by observing the analog output signal or by using the ac mode to determine the magnitude of the ac component.

Section 4

Remote Operation

RS-232 INTERFACE PARAMETERS

Prior to using the RS-232 serial port several parameters such as baud rate and character length must be set on the computer or PLC to match that of the meter. The meter's parameters cannot be changed. These are:

BAUD RATE:	2400
CHARACTER LENGTH:	8
PARITY:	NONE
STOP BITS:	1

RS-232 INTERFACE CONNECTION

EMC APPLICATION NOTE:

Use only high quality, double shielded cables for RS-232 connection. Keep the length of the cables less than 3 meters. Long cables (>3m) with insufficient EMI shielding can cause excessive emissions or may be susceptible to external interference.

The interface connector is a standard 9-pin "D" type connector commonly used on personal computers. Five signals are supported as shown in Figure 4-1. One of these is the common (ground) connection. Pins-1,4,6 and 9 are not connected.

REMOTE OPERATION

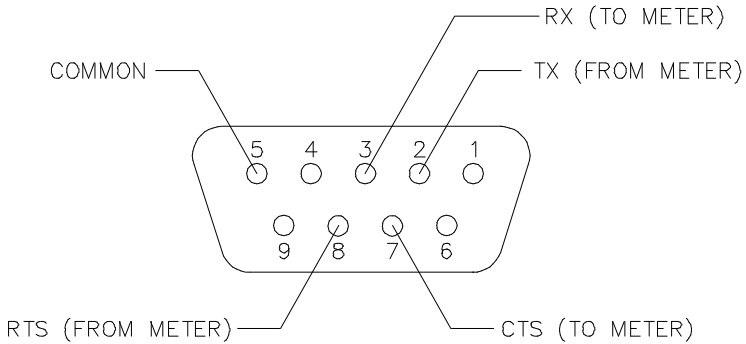

Figure 4-1
9-Pin Interface Connector

Data is transmitted to the meter on the receive (RX) line. Data is transmitted from the meter on the transmit (TX) line. This is known as a “full duplex” link.

In some RS-232 applications two lines called Clear-To-Send (CTS) and Request-To-Send (RTS) are used to control the flow of data between devices. This is often referred to as “hardware handshaking”. However, although these signals are connected electrically within the meter, the signals are not presently used. The user’s computer or PLC should be configured to ignore hardware handshaking lines.

In most cases a straight-through cable can be used between the meter and a personal computer. In other words Pin-1 on the meter would attach to Pin-1 on the computer, Pin-2 to Pin-2, etc. Figure 4-2 depicts two possible connection schemes.

REMOTE OPERATION

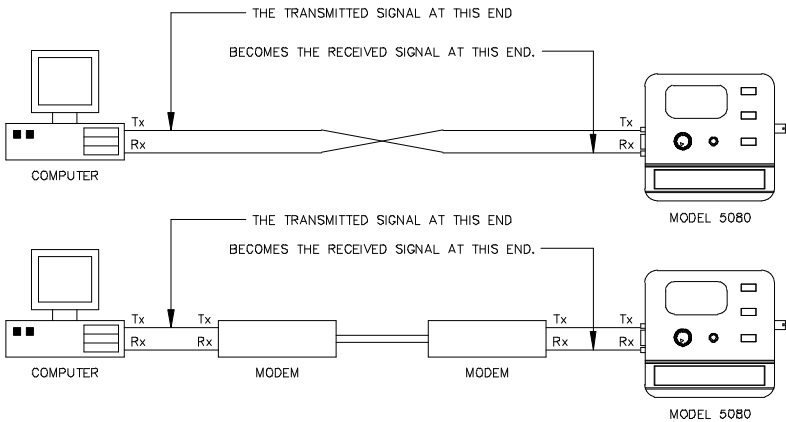

Figure 4-2
Serial Port Connection Schemes

Generally most communications problems are caused by incorrect wiring or failure to match the characteristics (baud rate, parity, etc.). Consult the documentation for the computer or PLC to determine the signal assignments for its communication connector. Again, the hardware handshake lines RTS and CTS are not supported and should be ignored.

REMOTE COMMAND STANDARDS

Prior to 1987 most instruments that featured RS-232 communications interfaces had their own unique commands for exchanging information. Eventually some manufacturers began offering models that recognized other manufacturer's commands so that customers could easily switch over without making extensive changes to their programs.

The IEEE-488-1987.2 standard (also called "IEEE-488.2") was one step toward creating a universal way to communicate with any instrument, regardless of the manufacturer or the type of instrument used. This was later enhanced by the SCPI-1991

REMOTE OPERATION

standard (Software Commands for Programmable Instruments), which defined specific commands and responses that covered a broad range of applications. Though these standards were targeted for use with the IEEE-488 instrumentation bus they are commonly used with serial (RS-232) interfaces as well.

The *Model 5080* supports many of the IEEE-488-1987.2 “common” commands as well as a subset of the SCPI-1991 commands.

COMMAND FORMAT

All commands consist of ASCII character strings. Some commands contain numeric parameters that are used to set or reset individual bits within binary registers. For instance a value of 45 decimal is the same as binary 101101, thus setting bits 5, 3, 2 and 0 in the register and resetting all others. Sending the value “00101101” would be interpreted as the number 101,101.

NOTE: No more than 500 characters can be sent in one command string.

MESSAGE TERMINATORS

When transmitting a string to the instrument the message must be “terminated” properly to notify the instrument that the message is complete. This is done by appending an ASCII line feed (LF) character as the final character in the string, which is a 0A hex or 00001010 binary. Note that 0A hex is equivalent to 10 decimal, but sending the two ASCII characters “10” will not work. It must be the single byte representation of the LF control character.

The meter will always send the LF character every time it transmits a message to the host system.

ERROR BUFFER

Errors are generated by a variety of sources, such as hardware errors or errors in the command syntax. If an error occurs a message is stored in an ERROR BUFFER. The message can be retrieved by a specific command discussed later in this section.

STATUS REGISTERS

There are four register sets that indicate the status of the instrument, such as errors or the present state of the meter. These are 8-bit registers, but in many cases not all of the bits are used. The four register sets are called

MEASUREMENT EVENT
OPERATION EVENT
STANDARD EVENT
QUESTIONABLE EVENT

There is also an 8-bit register that provides a 1-bit summary for each of the four register sets. This is called the STATUS BYTE.

Each register set consists of three individual registers, as depicted in Figure 4-3.

- 1) The CONDITION register is a real time, read-only register that is constantly updated to reflect current operating conditions.
- 2) The EVENT register is fed by the CONDITION register, but operates as a latch. Whenever any bit in the CONDITION register goes to "1", a corresponding "1" is latched into the EVENT register and remains that way until cleared by a specific command.

REMOTE OPERATION

3) The ENABLE register is a mask register that is used to generate the single status bit for the STATUS BYTE. Setting any bit in the ENABLE register to “1” will allow a corresponding “1” in the EVENT register to set the summary bit in the STATUS BYTE.

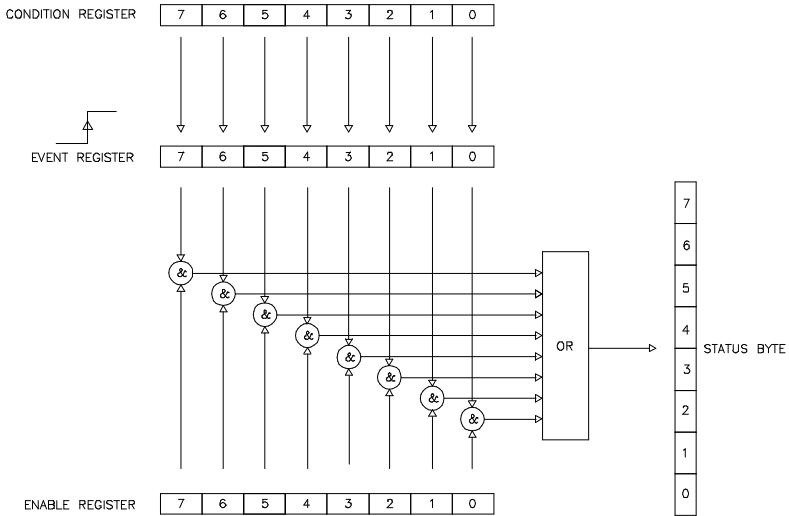

Figure 4-3
Condition, Event and Enable registers

STATUS BYTE AND REQUEST FOR SERVICE (RQS)

A bit in the STATUS BYTE called RQS (request for service) sets whenever an event occurs that requires the attention of the computer. The RQS bit can set if any of the summary bits from the MEASUREMENT EVENT, OPERATION EVENT, STANDARD EVENT or QUESTIONABLE EVENT registers are set, or if an error message exists. The STATUS ENABLE register is a mask register that is used to allow any of these conditions to set the RQS bit. Setting any bit in the STATUS ENABLE register to “1” will allow a corresponding “1” in the STATUS BYTE register to set the RQS bit. These registers are depicted in Figure 4-4.

REMOTE OPERATION

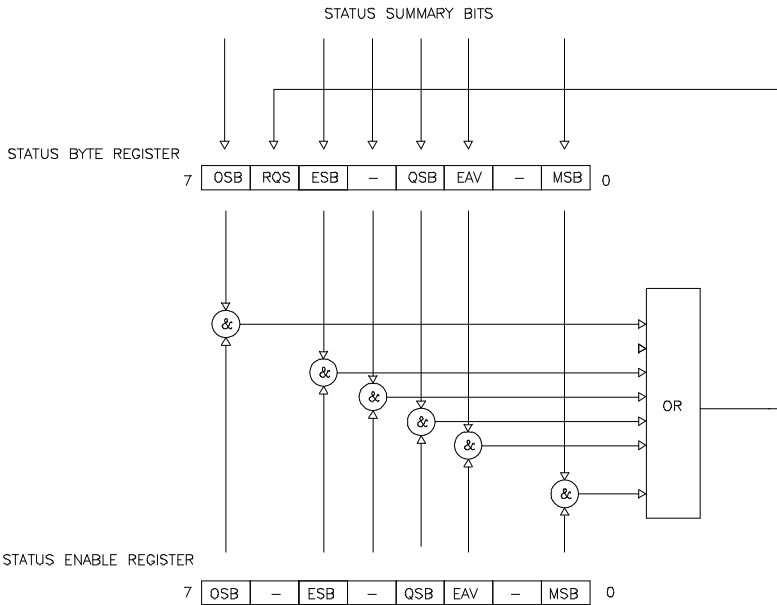

Figure 4-4
Status Byte and Enable registers

OSB -
Operation
Summary Bit:

If any of the bits in the OPERATION EVENT register set, and their respective enable bits are set, the Operation Summary Bit (OSB) will set.

ESB -
Event
Summary Bit:

If any of the bits in the STANDARD EVENT register set, and their respective enable bits are set, the Event Summary Bit (ESB) will set.

QSB -
Questionable

If any of the bits in the QUESTIONABLE EVENT register set, and their respective

REMOTE OPERATION

Summary Bit:	enable bits are set, the Questionable Summary Bit (QSB) will set.
MSB - Measurement Summary Bit:	If any of the bits in the MEASUREMENT EVENT register set, and their respective enable bits are set, the Measurement Summary Bit (MSB) will set.
EAV - Error Available:	This bit sets any time there is an error message available in the error buffer.
RSQ - Request For Service:	If any of the other bits in the STATUS BYTE are set, and their respective enable bits are set in the STATUS ENABLE register, the Request For Service (RQS) will set.

STANDARD EVENT REGISTER

If any of these bits set, and their respective enable bits are set, the Event Summary Bit (ESB) will set in the STATUS BYTE.

7	6	5	4	3	2	1	0
PON	–	CME	EXE	DDE	–	–	OPC

Figure 4-5
Standard Event register

PON -
Power On: Indicates that the meter was turned off and on since the last communication.

CME -
Command Error: Indicates that there was a syntax or spelling error in the command, or the command received is not supported.

EXE -
Execution Error: Indicates that the meter detected an error while attempting to execute a command.

DDE -
Device Dependent Error: Indicates that the meter did not operate properly due to some internal error.

OPC -
Operation Complete: Indicates that all requested operations have been completed.

REMOTE OPERATION

MEASUREMENT EVENT REGISTER

If any of these bits set, and their respective enable bits are set, the Measurement Summary Bit (MSB) will set in the STATUS BYTE.

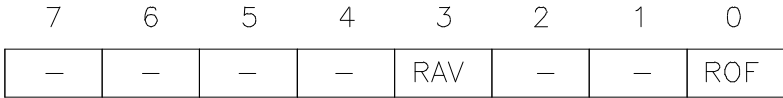

Figure 4-6
Measurement Event register

ROF - Reading Overflow: Indicates that the present reading exceeds the present measurement range.

RAV - Reading Available: Indicates a reading was acquired and processed.

OPERATION EVENT REGISTER

If any of these bits set, and their respective enable bits are set, the Operation Summary Bit (OSB) will set in the STATUS BYTE.



Figure 4-7
Operation Event register

MEAS - Measure mode: Indicates the meter is in the process of acquiring and processing a reading.

QUESTIONABLE EVENT REGISTER

If any of these bits set, and their respective enable bits are set, the Questionable Summary Bit (QSB) will set in the STATUS BYTE.

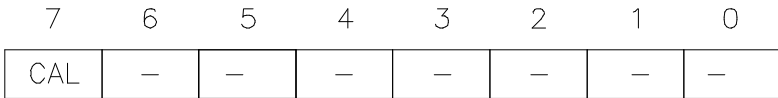

Figure 4-8
Questionable Event register

CAL - Indicates that an invalid calibration constant was detected during power up or when the probe was installed. The instrument will instead use a default parameter. This bit will clear once the meter and probe have been successfully calibrated.

Calibration summary:

NOTE: Meter specifications are not guaranteed when the CAL bit is set !

“COMMON” COMMAND SYNTAX

The “common” commands are recognized and acted upon in a similar manner by all instruments that follow the IEEE-488.2 standard, whether a DVM, scope, frequency meter, gaussmeter, etc. These are the syntax rules:

1) A common command always begins with an asterisk character (*) followed by a three or four character acronym and possibly one other parameter. For instance the command to clear the event registers is *CLS.

REMOTE OPERATION

- 2) The commands are not case sensitive. For instance the *CLS, *cls and *cLS commands are identical.
- 3) If there is a fourth character in the acronym it will always be a question mark (?) and indicates that information is being requested from the instrument. For instance a command to read the model number and manufacturer of the instrument is *IDN?.
- 4) If a parameter follows a command it must be separated from the acronym by one space. The parameter is the ASCII representation of an integer. For instance if the parameter to be sent is binary 1100, the actual parameter sent would be the two ASCII characters 12, since binary 1100 = decimal 12. If you were to send the four ASCII characters 1100 it would be interpreted as decimal 1100 (eleven hundred).
- 5) A number returned from the instrument is an ASCII representation of a number. For instance if the instrument returns the ASCII string 345 the number is decimal 345 (three hundred forty five), which translates to 159 hex.
- 6) Multiple commands can be sent in one string. The commands must be separated by semicolons (;). For instance, *CLS;*IDN? first clears the event registers and then requests model and manufacturer information. If more than one of the commands in the string requests information from the instrument, the instrument's response will also have semicolons separating the responses, such as 345;0;10.

REMOTE OPERATION

“COMMON” COMMANDS

ACRONYM	NAME	BRIEF DESCRIPTION
*CLS	Clear status	Clear all event registers and error buffer.
*ESE <NRf>	Program event enable	Program standard event enable register.
*ESE?	Event enable query	Read standard event enable register.
*ESR?	Event status query	Read standard event register and clear it.
*IDN?	Identification query	Return manufacturer, model number, software version number.
*OPC	Set operation complete	Set the Operation Complete bit in the standard event register after all commands have been executed.
*OPC?	Operation complete query	Returns an ASCII “1” after all commands have been executed.
*OPT?	Option identification query	Returns information about the attached Hall probe.
*SRE <NRf>	Program Status enable	Program STATUS enable register.
*SRE?	Status enable query	Read STATUS enable register.
*STB?	Status byte query	Read status byte register.

Table 4-1
Common command summary

REMOTE OPERATION

- *CLS - CLEAR STATUS** Clears the MEASUREMENT EVENT, OPERATION EVENT, STANDARD EVENT and QUESTIONABLE EVENT registers, but not their enable registers. It also clears the error buffer.
- *ESE <NRf> - PROGRAM STANDARD EVENT ENABLE REGISTER** A set bit in the STANDARD EVENT ENABLE register allows its corresponding event to set the ESB (event summary bit) in the STATUS BYTE register. <NRf> is an ASCII string representing an integer mask. For instance a value of 45 decimal is the same as binary 00101101, thus setting bits 5, 3, 2 and 0 in the enable register.
- *ESE? - STANDARD EVENT ENABLE REGISTER QUERY** Returns the contents of the STANDARD EVENT ENABLE register.
- *ESR? - STANDARD EVENT REGISTER QUERY** Returns the contents of the STANDARD EVENT register.
- NOTE: The STANDARD EVENT register is cleared after an *ESR? command.
- *IDN? - IDENTIFICATION QUERY** Returns the following string: F.W.BELL, MODEL 5080,Rx.x. The Rx.x string is the firmware revision level, where x.x is a decimal number, such as 1.1.
- *OPC - SET OPERATION COMPLETE** Causes the OPC (operation complete) bit to set in the STANDARD EVENT register when all commands have been executed.

REMOTE OPERATION

- *OPC? -**
OPERATION
COMPLETE
QUERY
- Causes the OPC (operation complete) bit to set in the STANDARD EVENT register and returns an ASCII "1" when all commands have been executed.
- *OPT? -**
OPTION
IDENTIFICATION
QUERY
- Returns a string that identifies the model number and serial number of the Hall probe. The model number will always be 12 characters in length including trailing spaces, such as STD58-0404. Following the model number will be a comma (,). Next will be the serial number, which will always be ten characters in length including trailing spaces, such as 9623004. If no probe is attached or can't be identified the string will default to "UNDEFINED ,0".
- *SRE <NRf> -**
PROGRAM
STATUS ENABLE
REGISTER
- A set bit in the STATUS ENABLE register allows its corresponding event to set the RQS (request for service) in the STATUS BYTE register. <NRf> is an ASCII string representing an integer mask. For instance a value of 45 decimal is the same as binary 00101101, thus setting bits 5, 3, 2 and 0 in the enable register.
- *SRE? -**
STATUS ENABLE
REGISTER QUERY
- Returns the contents of the STATUS ENABLE register.

REMOTE OPERATION

***STB?** -
STATUS BYTE
QUERY

Returns the contents of the STATUS
BYTE register.

NOTE: The STATUS BYTE register is not cleared after an *STB? command. Other registers and buffers must be cleared for the bits in the STATUS BYTE register to be cleared.

SCPI COMMAND SYNTAX

The SCPI commands go one step farther than IEEE-488.2 and provide a language protocol and defines a standard set of commands to program every aspect of the instrument. These are the syntax rules:

- 1) The first character of any command string is a colon (:).
- 2) The commands are not case sensitive. For instance the :MEASURE, :measure and :MEASure commands are identical.
- 3) A question mark (?) in a command means that the command is requesting information from the instrument. This is called a query command.
- 4) For any command there is a short and long spelling of the command. Use the following rules for the short version:
 - a) If the length of the command is four letters or less, there is no short version.

REMOTE OPERATION

b) If the command has more than four letters and the fourth letter is a vowel, drop it and all letters that follow it. For instance the command :RESET can be shortened to :RES.

c) If the command has more than four letters and the fourth letter is a consonant, drop all letters that follow it. For instance the command :MEASURE can be shortened to :MEAS.

d) If the command contains a question mark (?) or a non-optional parameter it must be included after the short form version. For instance a query command of :CONDITION? can be shortened to :COND?.

e) The use of anything other than the short or long version of a command is not permitted. For instance both the :MEASURE and :MEAS commands are acceptable, but :MEASU is not.

5) If a parameter follows a command it must be separated from the command by one space.

6) Multiple commands can be sent in one string. The commands must be separated by semicolons (;). A colon (:) must still precede each command. If more than one of the commands in the string requests information from the instrument, the instrument's response will also have semicolons separating the responses, such as 345;0;10.

REMOTE OPERATION

SCPI COMMANDS

In the following discussion the commands are written such that the short form of the command is written in UPPER CASE letters and the remainder of the command is written in lower case letters. Either form can be used.

If parameters are required they will appear within <> brackets. An <n> parameter is a single ASCII digit. <NRf> is usually a multiple digit number.

The meter supports a subset of the available SCPI commands. However, there are some functions that are not supported with standard SCPI commands. In these cases these special commands are patterned after other SCPI commands that are similar in function.

ERROR MESSAGE COMMANDS	DESCRIPTION
:SYSTem:ERRor?	Retrieve error message
:SYSTem:CLEar	Clear error message

STATUS REGISTER COMMANDS	DESCRIPTION
:STATus:MEASurement:EVENT?	Query Measurement Event reg.
:STATus:OPERation:EVENT?	Query Operation Event reg.
:STATus:QUESTionable:EVENT?	Query Questionable Event reg.
:STATus:MEASurement:ENABLE <NRf>	Program Measurement Event Enable reg.

Table 4-2
SCPI Command summary

REMOTE OPERATION

:STATus:OPERation:ENABLE <NRf>	Program Operation Event Enable reg.
:STATus:QUESTionable:ENABLE <NRf>	Program Questionable Event Enable reg.
:STATus:MEASurement:ENABLE?	Query Measurement Event Enable reg.
:STATus:OPERation:ENABLE?	Query Operation Event Enable reg.
:STATus:QUESTionable:ENABLE?	Query Questionable Event Enable reg.
:STATus:MEASurement:CONDition?	Query Measurement Condition reg.
:STATus:OPERation:CONDition?	Query Operation Condition reg.
:STATus:QUESTionable:CONDition?	Query Questionable Condition reg.
:STATus:PRESet	Clear all event registers.

MODE COMMANDS	DESCRIPTION
:UNIT:FLUX:AC:GAUSSs	Program ac gauss mode
:UNIT:FLUX:AC:TESLa	Program ac tesla mode
:UNIT:FLUX:AC:AM	Program ac amp-meter mode
:UNIT:FLUX:DC:GAUSSs	Program dc gauss mode
:UNIT:FLUX:DC:TESLa	Program dc tesla mode

Table 4-2 (cont.)
SCPI Command summary

REMOTE OPERATION

:UNIT:FLUX:DC:AM	Program dc A-M mode
:UNIT:FLUX?	Query mode setting

RANGE COMMANDS	DESCRIPTION
:SENSe:FLUX:RANGe:AUTO	Program auto range
:SENSe:FLUX:RANGe <n>	Program fixed range
:SENSe:FLUX:RANGe?	Query range setting

HOLD COMMANDS	DESCRIPTION
:SENSe:HOLD:STATe <n>	Program hold mode
:SENSe:HOLD:STATe?	Query hold mode setting
:SENSe:HOLD:RESet	Reset presently held value

ZERO / RELATIVE COMMANDS	DESCRIPTION
:SYSTem:AZERo	Initiates an automatic zero operation
:SYSTem:ARELative:STATe <n>	Program relative mode
:SYSTem:ARELative:STATe?	Query relative mode setting

MEASUREMENT COMMANDS	DESCRIPTION
:MEASure:FLUX?	Obtain flux density reading.

ANALOG OUTPUT COMMANDS	DESCRIPTION
:SYSTem:OUT <n>	Enable / disable analog output.

Table 4-2 (cont.)
SCPI Command summary

ERROR MESSAGES AND COMMANDS

If an error occurs a message is placed in the error buffer. The message will contain a number, a comma (,) and a brief description of the error. Negative (-) numbers are used for SCPI defined messages while positive (+) numbers relate specifically to the meter.

Each time the buffer is read the error message is removed from the buffer. If no error exists the message "0, No error" will be returned. However, if the buffer contains any other message, and a new error occurs before the old one is read or cleared, the new message will be lost.

There are certain error status bits that will set in the STANDARD EVENT register. These bits provide general error indications. The error message will provide more detailed information about the errors.

The error buffer can be read and cleared with the following commands:

:SYSTem:ERRor? Returns the error message and clears the error buffer.

:SYSTem:CLEar Clears the error buffer.

If the meter detects an error in the command string (a spelling error, a command that is not supported or a numerical value that is incorrect) the meter will not execute the command. If the error is detected in the middle of a multiple command string the command that contains the error and all commands that follow will not be executed. The user's program should always check the STATUS BYTE to determine if an error has occurred.

The possible error messages are:

REMOTE OPERATION

- 0, NO ERROR
- 201, NOT IN MEASURE MODE
- 120, NUMERIC DATA ERROR
- 224, ILLEGAL PARAMETER ERROR
- 363, INPUT BUFFER OVERRUN
- 103, INVALID SEPARATOR
- 102, SYNTAX ERROR
- 100, COMMAND ERROR

REMOTE OPERATION

STATUS COMMANDS

The STATUS commands control and query the MEASUREMENT EVENT, OPERATION EVENT and QUESTIONABLE EVENT registers.

:STATus:MEASurement:EVENT?	Returns the contents of the specified EVENT register, then <u>clears the register contents.</u>
:STATus:OPERation:EVENT?	
:STATus:QUEStionable:EVENT?	
:STATus:MEASurement:ENABLE <NRf>	Programs the specified EVENT ENABLE register with the value <NRf>. <NRf> is an ASCII string representing an integer mask. For instance a value of 45 decimal is the same as binary 00101101, thus setting bits 5, 3, 2 and 0 in the enable register.
:STATus:OPERation:ENABLE <NRf>	
:STATus:QUEStionable:ENABLE <NRf>	
:STATus:MEASurement:ENABLE?	Returns the contents of the specified EVENT ENABLE register.
:STATus:OPERation:ENABLE?	
:STATus:QUEStionable:ENABLE?	

REMOTE OPERATION

:STATus:MEASurement:CONDition?
:STATus:OPERation:CONDition?
:STATus:QUEStionable:CONDition?

Returns the contents of the specified EVENT CONDITION register. The EVENT CONDITION register is a real-time register reflecting the state of the meter at the time of the read. Some conditions could happen very quickly and could be missed by this query. It is often better to rely on the contents of the EVENT register since it latches the event until cleared by a specific command.

:STATus:PRESet

Clears all EVENT ENABLE registers.

REMOTE OPERATION

MODE COMMANDS

These commands select readings in either GAUSS, TESLA or AMP-METERS, and flux density readings for either static fields (dc) or alternating fields (ac). See Section-3 for more information.

NOTE: These commands will not be executed unless the function selector switch is in the MEASURE position.

:UNIT:FLUX:AC:GAUSS	Specifies ac flux density readings in gauss.
:UNIT:FLUX:AC:TESLa	Specifies ac flux density readings in tesla.
:UNIT:FLUX:AC:AM	Specifies ac flux density readings in amp-meters.
:UNIT:FLUX:DC:GAUSS	Specifies dc flux density readings in gauss.
:UNIT:FLUX:DC:TESLa	Specifies dc flux density readings in tesla.
:UNIT:FLUX:DC:AM	Specifies dc flux density readings in amp-meters.
:UNIT:FLUX?	Returns an ASCII string representing the present mode setting for the meter. The ASCII string can be DC GAUSS, AC GAUSS, DC TESLA, AC TESLA, AC AM or DC AM.

REMOTE OPERATION

RANGE COMMANDS

These commands select either a fixed range or AUTO range. See Section-3 for more information.

NOTE: These commands will not be executed unless the function selector switch is in the MEASURE position.

:SENSe:FLUX:RANGe:AUTO	Selects the AUTO RANGE function.
:SENSe:FLUX:RANGe <n>	Selects a fixed range <n>, where n = 0 for 300 G / 30 mT / 23.88 kAm 1 for 3 kG / 300 mT / 238.8 kAm 2 for 30 kG / 3 T / 2388 kAm
:SENSe:FLUX:RANGe?	Returns an ASCII digit representing the present range setting for the meter, as follows: 0 for 300 G / 30 mT / 23.88 kAm 1 for 3 kG / 300 mT / 238.8 kAm 2 for 30 kG / 3 T / 2388 kAm

REMOTE OPERATION

HOLD COMMANDS

These commands select one of the HOLD modes or resets the presently held reading. See Section-3 for more information.

NOTE: These commands will not be executed unless the function selector switch is in the MEASURE position.

- :SENSe:HOLD:STATe <n>** Selects the HOLD function, where <n> is a single ASCII digit, as follows:
- 0 = All HOLD modes turned off.
 - 1 = MIN HOLD on.
 - 2 = MAX HOLD on.
 - 3 = PEAK HOLD on.
- :SENSe:HOLD:STATe?** Returns an ASCII digit representing the present HOLD mode setting, as follows:
- 0 = All HOLD modes turned off.
 - 1 = MIN HOLD on.
 - 2 = MAX HOLD on.
 - 3 = PEAK HOLD on.
- :SENSe:HOLD:RESet** This command resets the presently held reading.

REMOTE OPERATION

ZERO COMMAND

This command initiates an automatic ZERO operation. See Section-3 for more information.

NOTE: This command will not be executed unless the function selector switch is in the MEASURE position.

:SYSTem:AZERo Automatic zeroing is initiated upon receipt of this command.

RELATIVE COMMANDS

These commands control the RELATIVE function. See Section-3 for more information.

NOTE: These commands will not be executed unless the function selector switch is in the MEASURE position.

:SYSTem:ARELative:STATe <n> The relative function is turned off when <n> is 0. When <n> is 1 the relative function is turned on, using the previously generated relative value, if any. When <n> is 2 the relative function is turned on and an automatic relative operation is initiated.

:SYSTem:ARELative:STATe? Returns a single ASCII digit indicating the on / off state of the relative function. A 0

REMOTE OPERATION

indicates the relative function is turned off. A 1 indicates the relative function is turned on.

MEASUREMENT COMMAND

This command acquires a new flux density reading.

NOTE: This command will not be executed unless the function selector switch is in the MEASURE position.

:MEASure:FLUX? This command returns the latest flux density reading. The returned string will contain a signed real number and a unit indicator (G, T, or Am). If in the ac mode the reading will not contain a polarity character (+ or -).

The ranges of possible readings for the various units of measure are:

0.0G to 29990G
0.00000T to 2.999T
0Am to 2,388,000Am

REMOTE OPERATION

ANALOG OUTPUT COMMAND

This command enables or disables the ANALOG OUTPUT. See Section-3 for more information.

NOTE: This command will not be executed unless the function selector switch is in the MEASURE position.

:SYSTem:OUT <n>

Enables or disables the ANALOG OUTPUT, where <n> is a single ASCII digit, as follows:

0 = Analog output turned off.

1 = Analog output turned on, low frequency mode.

2 = Analog output turned on, high frequency mode.

INTERMIXING “COMMON” AND SCPI COMMANDS

As mentioned earlier a string sent to the instrument can contain more than one command as long as the commands are separated by semicolons(;). “Common” and SCPI commands can be intermixed. For instance the string

```
*CLS;;UNIT:FLUX:DC:TESLA;;MEASure:FLUX?
```

is valid, first clearing the instrument’s event and error registers, then programming it to supply readings in tesla in the dc mode and requesting the latest reading. The host system should be prepared to receive the reading immediately after transmitting this command string to the meter.

USING QUERY COMMANDS

When any query command is issued the meter will send its response back immediately. However if a query command is part of a multiple command string the meter will transmit the response after all commands within the string have been executed. For instance here is such a string:

```
:UNIT:FLUX:DC:GAUSS;;MEAS:FLUX?;;UNIT:FLUX:DC:TESLA;  
:MEAS:FLUX? <LF>
```

In this string the meter is programmed for DC GAUSS mode and a measurement is requested. Then the meter is programmed for DC TESLA mode and another measurement is requested. When the meter has finished executing the entire command string it will transmit a string similar to this:

```
+1892G;+0.1892T;<LF>
```

REMOTE OPERATION

USING THE OPERATION COMPLETE STATUS

There are several ways to determine if the meter has executed a command. If the command string contains a query command the program can simply wait for the meter to transmit its response. But if the query command contains an error the command may never be executed. Further, some commands do not require a response. The best way to handle all situations is to issue the *OPC? command once prior to sending any other commands. This will cause the meter to always transmit an ASCII "1" each time it executes a command string. If the command string contains one or more query commands, the "1" will be appended to the end of the response separated by a semicolon (;). For instance the response to the command string

```
*OPC?;:UNIT:FLUX:AC:GAUSS <LF>
```

would be "1;<LF>", whereas the response to a command string containing a query

```
*OPC?;:MEAS:FLUX? <LF>
```

might be "+221.3G;1;<LF>".

EXAMPLE PROGRAM

Of the many programming languages available such as C, Pascal, BASIC, Fortran, etc., BASIC is probably the best known and understood by the most people. For this reason the following example program was written in Microsoft MS-DOS Q-BASIC for 80x86 style personal computers.

The following program is provided as a guide for programmers who wish to develop their own programs. It was written for clarity and is not necessarily the most efficient in terms of speed or size. Not all of the commands are demonstrated, but enough are used to serve as a general guide for using the other commands.

```
DECLARE SUB METER.I.O (expect.response%, timeout%)
DIM SHARED METER.CMD$, METER.RESP$, METER.ERROR%

CLS
PRINT "*****"
PRINT "          RS-232 DEMONSTRATION PROGRAM FOR"
PRINT "          F.W.BELL MODEL-5080 GAUSS / TESLA METER"
PRINT "*****"
PRINT "This program demonstrates the use of the RS-232 serial port on an"
PRINT " F.W.BELL Model-5080 gauss / tesla meter. This Q-BASIC program"
PRINT " was intended for use on any 80x86 PC using the COM-2 serial port."
PRINT " To use another comm port change the OPEN statement near the start"
PRINT " of the program."
PRINT ""
PRINT "This program can be used to verify the connection between the meter"
PRINT " and computer as well as provide a template for system programmers"
PRINT " who wish to create their own programs. You can use a straight-thru"
PRINT " cable from the meter to the PC. See the user's manual for more"
PRINT " information."
PRINT
PRINT "Turn the meter on and place the function selector to the MEASURE "
PRINT " position. Press any key to continue...";

DO: LOOP UNTIL INKEY$ <> "" : CLS

PRINT "Initializing COM2 port..."
OPEN "COM2:2400,N,8,1,CS,DS,CD" FOR RANDOM AS #1
```

REMOTE OPERATION

*Now that the COM-2 port has been opened an attempt is made to communicate with the meter. The *OPC? command is sent which should cause the meter to send back a "1;". If no response is received an error message is displayed and the program is terminated.*

```
ON ERROR GOTO TRY.AGAIN
```

```
'=====
'Attempt to communicate with meter.
'=====
PRINT "Verifying interface..."
METER.CMD$ = "**OPC?": CALL METER.I.O(1, 1)
```

```
IF METER.ERROR% = 1 THEN
    PRINT "Meter did not respond as requested. Please check your"
    PRINT " interface cable. Make sure it is connected to the COM2"
    PRINT " port on your computer."
    END
END IF
```

Now that the communications link between meter and computer has been established the I.D. information for the meter and probe is requested and displayed.

```
'=====
'Request meter / probe I.D. information and display it.
'=====
PRINT "Retrieving meter I.D. information...": PRINT
METER.CMD$ = "**IDN?;*OPT?": CALL METER.I.O(1, 1)

POS1% = INSTR(METER.RESP$, ";")
PRINT "Manufacturer = "; LEFT$(METER.RESP$, POS1% - 1);
POS2% = INSTR(POS1% + 1, METER.RESP$, ";")
PRINT " Model = "; MID$(METER.RESP$, POS1%+1, (POS2% - POS1% - 1));
POS1% = INSTR(POS2% + 1, METER.RESP$, ";")
PRINT " Revision = "; MID$(METER.RESP$, POS2%+1, (POS1%-POS2%- 1))
POS2% = INSTR(POS1% + 1, METER.RESP$, ";")
PRINT "Probe Model = ";
PRINT MID$(METER.RESP$, POS1% + 1, (POS2% - POS1% - 1));
```

REMOTE OPERATION

```
POS1% = INSTR(POS2% + 1, METER.RESP$, ";")
PRINT " Probe Serial = ";
PRINT MID$(METER.RESP$, POS2% + 1, (POS1% - POS2% - 1))
PRINT
```

```
PRINT "Press any key to continue....."
DO: LOOP UNTIL INKEY$ <> "" : CLS
```

The user is now instructed to insert the probe into the zero flux chamber or any dc field lower than 30 mT (300G). The meter will be instructed to perform an automatic zeroing, which will take several seconds to complete. If the meter reports an error the error message will be displayed.

```
'=====
'Demonstrate the AUTO-ZERO function.
'=====
PRINT "The automatic zeroing function will now be demonstrated."
PRINT
PRINT "Insert the probe into the zero flux chamber or in any magnetic"
PRINT " field less than 30 mT (300 G)."
PRINT
PRINT "Press any key when ready.....": PRINT
```

```
DO: LOOP UNTIL INKEY$ <> ""
```

```
PRINT "AUTO ZERO is in process...please wait...."
METER.CMD$ = ":SYSTEM:AZERO"
CALL METER.I.O(1, 15)
METER.CMD$ = ":SYSTEM:ERR?": CALL METER.I.O(1, 1)
POS1% = INSTR(METER.RESP$, ";")
IF VAL(LEFT$(METER.RESP$, POS1% - 1)) <> 0 THEN
  CLS:BEEP
  PRINT "The meter has reported an error of "; METER.RESP$
  PRINT
  PRINT "Press any key to continue....."
  DO: LOOP UNTIL INKEY$ <> "" : CLS
END IF
```

REMOTE OPERATION

The meter is now set to the dc tesla mode with a fixed range of 300 mT

```
.  
'=====
```

```
'Program meter for DC-TESLA measurement on the 300 mT range.
```

```
'=====
```

```
CLS
```

```
PRINT "Programming meter for DC-TESLA mode, 300 mT range..."
```

```
METER.CMD$ = ":SYSTEM:CLEAR": CALL METER.I.O(1, 1)
```

```
METER.CMD$ = ":UNIT:FLUX:DC:TESLA;;SENSE:FLUX:RANGE 1"
```

```
CALL METER.I.O(1, 2)
```

Flux density readings are acquired and displayed on a continuous basis. The user can move the probe in and out of a magnetic field in order to observe the changes in the flux density readings.

```
'=====
```

```
'Acquire measurements and display them until the user presses a key.
```

```
'=====
```

```
LOCATE 10, 1
```

```
PRINT "Move the probe near a dc magnetic field and observe the  
PRINT " change in the present flux density reading."
```

```
PRINT
```

```
PRINT "Press any key when finished....."
```

```
DO
```

```
  METER.CMD$ = "MEAS:FLUX?": CALL METER.I.O(1, 2)
```

```
  POS1% = INSTR(METER.RESP$, ",")
```

```
  LOCATE 15, 15
```

```
  PRINT "Present flux density = "; LEFT$(METER.RESP$, POS1% - 1)
```

```
  METER.CMD$ = ":SYSTEM:ERR?": CALL METER.I.O(1, 1)
```

```
  POS1% = INSTR(METER.RESP$, ",")
```

```
  IF VAL(LEFT$(METER.RESP$, POS1% - 1)) <> 0 THEN
```

```
    CLS: BEEP
```

```
    POS1% = INSTR(METER.RESP$, ",")
```

```
    PRINT "The meter has reported an error of ";
```

```
    PRINT LEFT$(METER.RESP$, POS1% - 1)
```

```
    PRINT
```

```
    PRINT "Press any key to continue....."
```

REMOTE OPERATION

```
DO: LOOP UNTIL INKEY$ <> ""
EXIT DO
END IF
```

```
LOOP UNTIL INKEY$ <> ""
END
```

```
TRY.AGAIN:
RESUME NEXT                                'Comm error trap.
```

This subroutine handles the communications between the meter and the computer. The header contains specific information.

```
SUB METER.I.O (expect.response%, timeout%)
'=====
'                METER INPUT / OUTPUT SUBROUTINE
'=====
' This subroutine transmits the contents of the global buffer
' <METER.CMD$> to the meter, followed by the line feed terminator.
'
' If the variable <expect.response%> is non-zero, the subroutine will
' wait for a response from the meter and store it in the global buffer
' <METER.RESP$>. The program will wait for <timeout%> seconds for
' a response. If no response is received the command will be issued
' again. If still no response the global variable <METER.ERROR%> will
' be set to 1 and a normal return will be made.
'=====
RETRY = 2: METER.ERROR% = 0                'Clear error flag.

DO UNTIL EOF(1) = -1
METER.RESP$ = INPUT$(LOC(1), #1) 'Remove any residual bytes
LOOP                               ' from the input buffer.

SEND.COMMAND:
METER.RESP$ = ""                    'Null response buffer.
PRINT #1, METER.CMD$ + CHR$(10);    'Send command string
                                     ' followed by a line feed.

IF expect.response% = 0 THEN EXIT SUB 'Return if no response
                                     ' expected.
```

REMOTE OPERATION

RESET.TIMER:

```
START.TIME = TIMER
```

'Store as many characters as are in the input buffer. If one of them ' is the line feed character return to caller with the response in the '<METER.RESP\$> buffer. If no response is received within '<timeout%> seconds, try again. If still no response, set '<METER.ERROR%> to non-zero and return.

LOOK.FOR.INPUT:

```
IF EOF(1) = -1 THEN
  IF (TIMER - START.TIME) > timeout% THEN
    RETRY = RETRY - 1
    IF RETRY <> 0 THEN          'Send command one more time.
      GOTO SEND.COMMAND
    ELSE
      METER.ERROR% = 1        'Report an error if no response.
      EXIT SUB
    END IF
  ELSE
    GOTO LOOK.FOR.INPUT
  END IF

ELSE
  METER.RESP$ = METER.RESP$ + INPUT$(LOC(1), #1)
  IF (INSTR(METER.RESP$, CHR$(10))) = 0 THEN GOTO
    RESET.TIMER
  EXIT SUB
END IF

END SUB
```

WARRANTY

This instrument is warranted to be free of defects in material and workmanship. Sypris Test & Measurement's obligation under this warranty is limited to servicing or adjusting any instrument returned to the factory for that purpose, and to replace any defective parts thereof. This warranty covers instruments which, within one year after delivery to the original purchaser, shall be returned with transportation charges prepaid by the original purchaser, and which upon examination shall disclose to Sypris Test & Measurement's satisfaction to be defective. If it is determined that the defect has been caused by misuse or abnormal conditions of operation, repairs will be billed at cost after submitting an estimate to the purchaser.

Sypris Test & Measurement reserves the right to make changes in design at any time without incurring any obligation to install same on units previously purchased.

THE ABOVE WARRANTY IS EXPRESSLY IN LIEU OF ALL OTHER WARRANTIES EXPRESSED OR IMPLIED AND ALL OTHER OBLIGATIONS AND LIABILITIES ON THE PART OF SYPRIS TEST & MEASUREMENT, AND NO PERSON INCLUDING ANY DISTRIBUTOR, AGENT OR REPRESENTATIVE OF SYPRIS TEST & MEASUREMENT IS AUTHORIZED TO ASSUME FOR SYPRIS TEST & MEASUREMENT ANY LIABILITY ON ITS BEHALF OR ITS NAME, EXCEPT TO REFER THE PURCHASER TO THIS WARRANTY. THE ABOVE EXPRESS WARRANTY IS THE ONLY WARRANTY MADE BY SYPRIS TEST & MEASUREMENT. SYPRIS TEST & MEASUREMENT DOES NOT MAKE AND EXPRESSLY DISCLAIMS ANY OTHER WARRANTIES, EITHER EXPRESSED OR IMPLIED, INCLUDING WITHOUT LIMITING THE FOREGOING, WARRANTIES OF MERCHANTABILITY OR FITNESS FOR A PARTICULAR PURPOSE OR ARISING BY STATUE OR OTHERWISE IN LAW OR FROM A COURSE OF DEALING OR USAGE OR TRADE. THE EXPRESS WARRANTY STATED ABOVE IS MADE IN LIEU OF ALL LIABILITIES FOR DAMAGES, INCLUDING BUT NOT LIMITED TO CONSEQUENTIAL DAMAGES, LOST PROFITS OR THE LIKE ARISING OUT OF OR IN CONNECTION WITH THE SALE, DELIVERY, USE OR PERFORMANCE OF THE GOODS. IN NO EVENT WILL SYPRIS TEST & MEASUREMENT BE LIABLE FOR SPECIAL, INDIRECT OR CONSEQUENTIAL DAMAGES EVEN IF SYPRIS TEST & MEASUREMENT HAS BEEN ADVISED OF THE POSSIBILITY OF SUCH DAMAGES.

This warranty gives you specific legal rights, and you may also have other rights that vary from state to state.

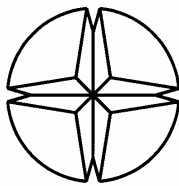

SYPRIS[®]
TEST & MEASUREMENT



6120 Hanging Moss Road
Orlando, FL 32807
Phone: 407-678-6900
Fax: 407-677-5765