



Advanced Test Equipment Corp.

www.atecorp.com 800-404-ATEC (2832)



VALHALLA
S C I E N T I F I C

Alpha 4314 Series

Standard (STD) and Reduced Current (KRC) Models

Digital Igniter Tester

Operations Manual

VALHALLA SCIENTIFIC INC. CERTIFICATION

Valhalla Scientific, Inc. certifies that this instrument was thoroughly tested and inspected and found to meet published specifications when shipped from the factory. Valhalla Scientific, Inc. further certifies that its calibration measurements are traceable to the Nation Institute of Standards and Technology to the extent allowed by NIST's calibration facility.

Due to continuing product refinement and due to possible parts manufacturer changes, Valhalla Scientific, Inc. reserve the rights to change any or all specifications without notice.

VALHALLA SCIENTIFIC INC. WARRANTY STATEMENT

The warranty period for this instrument is stated on your invoice and packing list. Please refer to these to determine appropriate warranty dates.

We will repair the instrument during the warranty period provided it is returned to Valhalla Scientific, Inc. freight prepaid. No other warranty is expressed or implied.

Valhalla Scientific, Inc. is not liable for consequential damages.

Permission and a Return Material Authorization number (RMA) must be obtained directly from the factory for warranty repairs. No liability will be accepted if returned without such permission.

Due to continuing product refinement and due to possible parts manufacturer change, Valhalla Scientific reserves the right to change any or all specifications without notice.

ALPHA 4314 Digital Igniter Tester User Manual
Revision # 65 Edition 3 (2019)
Copyright © 2019 Valhalla Scientific, Inc. All rights reserved



WARNINGS

The following general safety precautions must be observed during all phases of operation, service, and repair of this product. Failure to comply with these precautions or with specific warnings elsewhere in this manual violates safety standards of design, manufacture, and intended use of the product. Valhalla Scientific assumes no liability for the customer's failure to comply with these requirements.

Ground the equipment: For Safety class 1 equipment (equipment having a protective earth terminal), an interrupted safety earth ground must be provided from the main power source to the product input wiring terminals or supplied power cable.

DO NOT operate the product in an explosive atmosphere or in presence of flammable gases or fumes.

For continued protection, replace the line fuse(s) only with fuse(s) of the same voltage and current rating and type. **DO NOT** use repaired fuses or short-circuited fuse holders.

Keep away from live circuits: Operating personnel must not remove equipment covers or shields. Procedures involving the removal of covers or shields are for use service trained personnel only. Under certain conditions, dangerous voltage may exist even with the equipment switched off. To avoid dangerous electrical shock, **DO NOT** perform procedures involving cover or shield removal unless you are qualified to do so.

DO NOT operate damaged equipment: Whenever it is possible that the safety protection features built into this product have been impaired, either through physical damage, excessive moisture, or any reason, **REMOVE POWER** and do not use the product until safe operation can be verified by service-trained personnel. If necessary, return the product to Valhalla Scientific for service and repair to ensure that safety features are maintained.

DO NOT service or adjust alone: Do not attempt internal service or adjustment unless another person, capable of rendering first aid and resuscitation, is present.

DO NOT substitute parts or modify equipment: Because of the danger of introducing additional hazards, do not install substitute parts or perform any unauthorized modification to the product. Return the product to Valhalla Scientific for service and repair to ensure that safety features are maintained.

Measuring high voltage is always hazardous: ALL multimeters input terminals (both front and rear) must be considered hazardous whenever inputs greater than 42V (dc or peak) are connected to ANY input terminal.

Permanent wiring of hazardous voltage or sources capable of delivering greater than 150VA should be labeled, fused, or in some other way protected against accidental bridging or equipment failure.

DO NOT leave measurement terminals energized when not in use.

Table of Contents

Chapter 1 – General Information.....	1
Instrument Description.....	1
Safety Considerations.....	1
Instrument Identification.....	1
Chapter 2 – Unpacking and Installing.....	2
Inspection.....	2
Power Requirements.....	2
Installation.....	2
Chapter 3 – Specifications.....	3
Standard Current Models: Range/Resolution/Test Current/Failsafe Current.....	3
KRC Reduced Current Models: Range/Resolution/Test Current/Failsafe Current.....	3
Accuracy.....	4
Temperature.....	4
General Specifications.....	4
Physical Specifications.....	4
Chapter 4 – Optional Equipment.....	5
Available Options.....	5
Option A: Battery Charger.....	5
Replacement Batteries.....	5
Option CC4: Carrying Case.....	5
Option R4: Rack Mount Adapter.....	5
Test Leads.....	5
Option K: 4-Wire Kelvin Lead Set.....	5
Option MP-S: Single Probe Lead Set.....	5
Option MP-1: Kelvin Micro-Probes.....	5
Option MP-2: Kelvin Mini-Probes.....	5
Option MP-3: Kelvin Micro-Probes.....	6
Option MP-4/MP-5: Surface Probes.....	6
Option KK: 4-Wire Kelvin Lead Set.....	6
Option C: Banana-to-Clip Cable.....	6
Option BBL: Banana-to-Banana Cable.....	6

Option KCS: Kelvin Clips	6
Option JAWS: Heavy-Duty Clips	6
Interface.....	6
Option BCD: Data Output.....	6
Option RS232: Data Output	6
Chapter 5 - Operations.....	7
General.....	7
Front Panel.....	7
Power Switch	7
Range Switch.....	7
Rear Panel	7
Fuse holder.....	7
Charging Jack.....	7
4-Wire Resistance Measurement	8
Connections	9
Interpreting the Display	9
Failsafe Operation.....	9
Battery Monitoring Circuitry.....	10
Range Indicator LEDs	10
Chapter 6 - Troubleshooting.....	11
Localizing the Problem.....	11
Component Replacement.....	11
Chapter 7 - Routine Maintenance.....	12
General.....	12
Required Test Equipment	12
Precision Resistors:	12
Test Leads:	12
Voltage Standard:	12
DMM:	12
Power Supply:	12
Calibration Procedure	13
VOLTAGE SENSE ADJUSTMENTS for STANDARD CURRENT MODELS	13
VOLTAGE SENSE ADJUSTMENTS for KRC REDUCED CURRENT MODELS.....	13

RESISTANCE ADJUSTMENTS	14
FAILSAFE CHECK	14
LOW BATTERY & POWER-UP CHECK	15
Checking the Calibration Results	15
½ Scale and Linearity Check	15
Zero Check.....	15
Battery Replacement Instructions	15
Chapter 8 - Interface Operations	16
BCD Interface	16
Safety Isolated RS-232 Interface.....	17
Connecting the Alpha 4314 via RS232	17
COMMANDS AND SYNTAX	18
DETAILS OF COMMAND REFERENCE.....	18
Chapter 9 - Addendums	23

Chapter 1 – General Information

Instrument Description

The Valhalla Scientific Model Alpha 4314 Digital Igniter Tester is designed to provide extremely safe and reliable resistance testing of explosive or volatile devices. Some of the proven uses include: fuses, squibs, igniters, explosive bolts, automobile airbag initiators and many others.

Essentially, a Model Alpha 4314 is a 4-wire ohmmeter which has been designed to use very low test currents for its measurement. Additional circuitry proprietary to Valhalla Scientific is used to ensure that test current levels do not exceed the specified "failsafe current" even in a worst-case component failure situation. The failsafe feature is tested in every instrument before shipment and the results provided to the customer on a Certificate of Calibration that accompanies the unit.

The Alpha 4314 series consists of more than 35 different versions spanning the measurement range from 0.1m resolution to 200M full scale. The Alpha 4314 may have a maximum of four (4) of nine (9) ranges installed at any one time. Unless otherwise specified when placing the order, the Model Alpha 4314 with the 20, 200, 2k and 20k Ranges is the standard configuration. Instruments with special feature are also available. Please check any addendums that may apply to special Alpha 4314 versions.

Standard feature of the Alpha 4314 is a battery monitoring circuit that alerts the user if the batteries have become or will soon become unusable. Please refer to Chapter 5 for more details.

Front panel LED indicators provide a visual indication of which range are installed and which range is selected. Also refer to Chapter 5 for details.

Safety Considerations

The Alpha 4314 Digital Igniter Tester is a battery operated equipment, for an optimal function of the Failsafe circuitry DO NOT connect the battery charger while the instrument is in an ON position. Always disconnect the battery charger before operating the instrument.

Instrument Identification

Valhalla Scientific instruments are identified by a two part serial number. The Serial Tag is located on the rear or bottom of the instrument. The number is in a form of 00-0000. The first two digits, called the serial number prefix, indicate the model. It changes only when a change is made to the instrument. The last 4 digits, called the serial number suffix, are unique for each individual unit.

Be sure to include the entire serial number, both prefix and suffix, in any correspondence about your instrument.

The serial number can also be found on the Main Board, Calibration Tag and Certificate of Calibration.

Chapter 2 – Unpacking and Installing

Inspection

If the shipping carton is damaged, request that the carrier's agent be present when the unit is unpacked. If the instrument appears damaged, the carrier's agent should authorize repairs before the unit is returned to the factory. Even if the instrument appears undamaged, it may have suffered internal damage in transit that may not be evident until the unit is operated or tested to verify conformance with its specifications. If the unit fails to operate or fails to meet the performance specifications of Chapter 3, notify the carrier's agent and the nearest Valhalla Sales Office. Retain the shipping carton for the carrier's inspection. DO NOT return equipment to Valhalla Scientific or any of its sales offices prior to obtaining authorization to do so.

Power Requirements

The Model Alpha 4314 is powered by an internal rechargeable heavy-duty NiMH battery pack. The battery charge is maintained by an external AC/DC converter that plugs into a standard 100-240Vac 50-60Hz receptacle. The AC adapter provides 6VDC @ 1.25A.

For safety reasons, the Alpha 4314 may not be powered directly from the AC adapter. The Alpha 4314 must be turned off and have the adapter connected in order to charge the batteries.

The battery pack may power the Alpha 4314 for up to 10 hours before requiring a recharge.

Although the batteries are fully charged prior to shipment, it may be desirable to refresh the charge for 24 hours before use. As a rule of thumb, the Alpha 4314 requires twice as much time to fully recharge as the amount of discharge time. For example, if the instrument was used continuously for 2 hours, the AC adapter must be connected for 4 hours in order to fully restore the charge.

To avoid damage, do not turn on the Alpha 4314 while connected to a load.

Installation

The Model Alpha 4314 consumes little power and generates virtually no heat. Consequently, it may be used in any area where the environment does not exceed the temperature specifications of Chapter 3.

A rack mount adapter is available to allow installation of the Alpha 4314 in a standard 19" equipment rack. This option is designated as Option R4. When installing this instrument in a rack environment, avoid exposing the Alpha 4314 to extremes of temperature, which will affect the accuracy and shorten battery life-span. For installation instructions, please refer to the drawing included with the option.

Chapter 3 – Specifications

Standard Current Models: Range/Resolution/Test Current/Failsafe Current

Table 1.A – Standard Current Models

Range #	0	1	2	3	4	5	6	7	8
Range Value	2Ω	20Ω	200Ω	2kΩ	20kΩ	200kΩ	2MΩ	20MΩ	200MΩ
Resolution	100μΩ	1mΩ	10mΩ	100mΩ	1Ω	10Ω	100Ω	1kΩ	10kΩ
Test Current	10mA	10mA	1mA	100μA	10μA	1μA	100nA	10nA	1nA
Fail-Safe Current^[1]	16mA	16mA	1.8mA	180μA	18μA	1.8μA	180nA	18nA	1.8nA

[1] Max Value. The actual measured level is provided on the certificate of calibration.

KRC Reduced Current Models: Range/Resolution/Test Current/Failsafe Current

Table 2.B - Reduced Current Models

Range #	0	1	2	3	4	5	6
Range Value	2Ω	20Ω	200Ω	2kΩ	20kΩ	200kΩ	2MΩ
Resolution	100μΩ	1mΩ	10mΩ	100mΩ	1Ω	10Ω	100Ω
Test Current	5mA	5mA	500μA	50μA	5μA	500nA	50nA
Fail-Safe Current^[1]	8mA	8mA	1.8mA	180μA	18μA	1.8μA	180nA

[1] Max Value. The actual measured level is provided on the certificate of calibration.

Accuracy

Table 3

Range	Accuracy
2Ω	±0.02% of reading ± 0.02% of range
20Ω	±0.02% of reading ± 0.02% of range
200Ω	±0.02% of reading ± 0.02% of range
2kΩ	±0.02% of reading ± 0.02% of range
20kΩ	±0.02% of reading ± 0.02% of range
200kΩ	±0.05% of reading ± 0.05% of range
2MΩ	±1% of reading ± 0.2% of range
20MΩ	±2% of reading ± 0.2% of range
200MΩ	±3% of reading ± 1% of range

Temperature

Temperature Coefficient:	±0.002% per °C (from 0°C-15°C and 35°C-50°C) <i>not applicable for 200kΩ range and above.</i>
Operating Temperature Range:	0°C to 50°C
Storage Temperature Range:	-10°C to 70°C

General Specifications

Display Type:	4 ½ digits Light Emitting Diodes (LED) (19999)
Overload Indication:	Screen displays "O.L."
Conversion Rate:	3 readings per second
Terminal Configuration:	4-Wire Kelvin
Current Source Compliance Voltage:	Clamped at 1.6V
Power:	(4 "D" Cell) 1.2V rechargeable NiMH Batteries 10000mAh
Battery Charger:	100-240Vac 50-60Hz Input. Provides 6VDC at 1.25A nom.

Physical Specifications

Width:	9.5" / 24cm
Depth:	11" / 27cm
Height:	3" / 8cm
Weight:	3 lbs / 1.3kg net; 6lbs / 3kg shipping [2]

[2] Shipping weight may vary.

Chapter 4 – Optional Equipment

Available Options

Listed below are the options available for use with the Alpha 4314 Series Digital Igniter Testers.

Option A: Battery Charger

Option "A" is an AC/DC converter that converts 115VAC line voltage to 6VDC at 300mA. One charger is provided as a standard accessory with every Alpha 4314.

Replacement Batteries

The rechargeable NiMH batteries installed in the Alpha 4314 should provide years of trouble-free operation. Replacement, however, will eventually be necessary. The Alpha 4314 uses four 1.2V cells installed in a reusable battery box. The batteries are held in place by reusable tie-wraps. When ordering replacement batteries, please specify Valhalla Stock #05-10117, quantity four (4).

Option CC4: Carrying Case

Option "CC4" is a meter and accessory carrying case with extra room for test leads, battery charger, etc.

Option R4: Rack Mount Adapter

Option "R4" is an adapter tray that allows the Alpha 4314 to be installed in a standard 19" equipment rack.

Test Leads

Option K: 4-Wire Kelvin Lead Set

Option "K" is the recommended general purpose lead set for all Valhalla Ohmmeters. Option K is a shielded 48" lead set terminating in ½ inch gold plated clips.

Option MP-S: Single Probe Lead Set

Option "MP-S" is a 4-wire lead set terminated in single points. The 4-wire configuration is maintained up to the point of the probe, eliminating most cable resistance effects. Option MP-S may be used where a single probe tip is a must.

Option MP-1: Kelvin Micro-Probes

Option "MP-1" is a 48" shielded lead set (dual banana), handheld pencil type, terminated in spring loaded steel tips with .05" separation (1 amp max.). Special orders or modified versions available upon request.

Option MP-2: Kelvin Mini-Probes

Option "MP- 2" is a 48" shielded lead set, handheld pencil type, terminated in spring loaded steel tips with 0.18" separation. (1 Amp max.)

Option MP-3: Kelvin Micro-Probes

Option "MP-1" is a 48" shielded lead set (dual banana), handheld pencil type, terminated in spring loaded steel tips with .08" separation (1 amp max.). Special orders or modified versions available upon request.

Option MP-4/MP-5: Surface Probes

These probes permit rapid, repeatable bonding testing on a variety of screened or flat surfaces. Test current is evenly distributed through the probe base while sensing is accomplished via a spring loaded center contact. The "MP-4" target area is 1" in diameter. The "MP-5" target area is .4" in diameter.

Option KK: 4-Wire Kelvin Lead Set

Option "KK" is a 48" heavy duty cable set terminated in large "jaws" that have an open span of 2".

Option C: Banana-to-Clip Cable

Option "C" is a 48" shielded cable terminated in dual alligator clips

Option BBL: Banana-to-Banana Cable

Option "BBL" is a 48" shielded cable terminated in dual banana plugs at both ends.

Option KCS: Kelvin Clips

Option "KCS" is the gold plated Kelvin clips used on the Option "K" cable. These clips may be used when making custom cables or when repairing Option "K".

Option JAWS: Heavy-Duty Clips

2" opening for use on large bushings, transformers and motors. The upper/lower jaw teeth (gold plated) provide true 4-wire measurement. Can accommodate up to 150 amps.

Interface

Option BCD: Data Output

This option provides parallel BCD data on p rear-panel 50-pin connector. All outputs are TTL comparable levels with a drive capability of 1 LS load. The Option BCD may be used to drive the Valhalla Model 1248. (See Chapter 8)

Option RS232: Data Output

The interface is isolated to 2.5kV on both power and Data lines and uses iCoupler Technology. Option RS-232 provides a safe way to communicate with the Alpha 4314 via a computer or PLC and allows the transfer of single readings or continuous transmission of data. This interface is for data acquisition only and does not provide range control (See Chapter 8)

Chapter 5 - Operations

General

This section of the manual contains complete operating instructions for the Alpha 4314 Series Digital Igniter Testers. A description of the front panel controls, connection instructions, and the theory behind 4-wire resistance measurement is discussed in this section.

Front Panel

Power Switch

When the front panel power switch is placed in the OFF/CHARGE position, all power is removed from the output terminals, and the battery pack is connected to the charging circuit. When the switch is placed in the ON position, the battery pack is disconnected from the charging circuit. The possibility of a common mode voltage between the device under test and AC Power ground is therefore eliminated.

Range Switch

The Model Alpha 4314 input range is selected by depressing the desired button on a multi-station interlocking pushbutton array located on the right-hand side of the front panel. The pushbutton for the lowest resistance range is nearest to the POWER switch. LED indicators will point out the range and failsafe current selected.

Rear Panel

Fuse holder

The fuse holder is mounted on the rear panel and contains a 2 amp in-line fuse. This fuse is designed to protect the battery pack from excessive charging currents. Customers may request special models with the fuse holder mounted on the front panel. For continued protection, replace the line fuse only with fuse of the same voltage and current rating and type. DO NOT use repaired fuses or short-circuited fuse holders.

Charging Jack

The battery charging jack is a barrel type and is located on the Alpha 4314 rear panel. The center pin of the connector is positive. The charging requirements of the internal battery pack are 6VDC @300mA. The correct charging voltage is supplied by the adapter included with the instrument. Additional adapters are available as Option "A". Customers may request special models with the charger jack mounted on the front panel.

4-Wire Resistance Measurement

The four-terminal configuration of the Alpha 4314 eliminates errors normally caused by test lead and contact resistances. In many applications the contact resistance can exceed the value of the load by several orders of magnitude. The Alpha 4314 bypasses this potential error source by providing two terminals of constant current and an additional two terminals for high impedance voltage measurement. The result is a fast, accurate resistance measurement of the load, independent of the resistance of the current carrying leads.

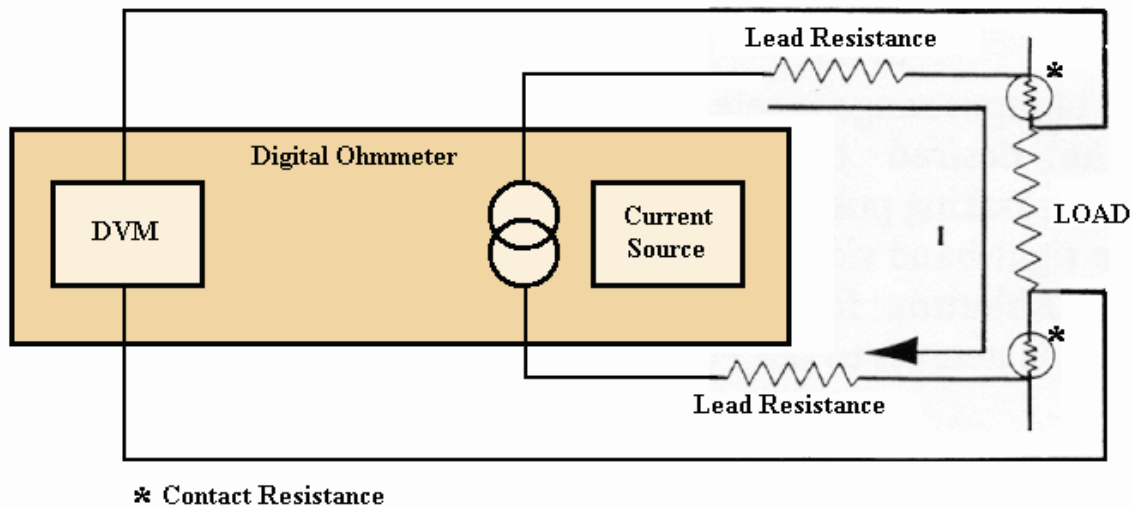

Figure 1 - Error Sources in Resistance Measurements

Figure 1 illustrates how the 4-wire principle is used to eliminate lead, wire and contact resistances as potential error sources. The internal current source inherently overcomes all series resistance (within compliance voltage limits) and delivers a precise constant current.

The internal high-impedance DVM senses the voltage drop across the load. There is negligible contact and lead resistance error created by the voltage measurement because the high input impedance of the DVM limits current flow in the voltage leads.

Connections

Connections are made to the front panel terminals using a 4-wire configuration as described in **4-Wire Resistance Measurement**. When using Valhalla test leads, the tabbed side of the banana jack is plugged into the current terminals. This ensures that the current is carried in the largest conductor and that the voltage input is shielded.

V_{HI} ⚙️ ⚙️ I_{HI} ← Tab
V_{LO} ⚙️ ⚙️ I_{LO} ← Tab

Interpreting the Display

All Valhalla ohmmeters use a high impedance voltmeter as part of the resistance measurement process. This voltmeter is a highly accurate and stable 4 ½ digit analog-to-digital converter (ADC). Unless it is receiving a definite input signal, the output reading of this ADC is ambiguous. The display may indicate a randomly wandering number or it may indicate an over-range condition. This unpredictable display may make it seem to appear that the instrument is experiencing some sort of malfunction. It is, in fact, just a characteristic of the voltmeter circuit and should not be mistaken for a fault in the instrument.

The display indications should be ignored unless there is a definite measurement being taken. If this wandering display is not acceptable, the ohmmeter can be made to indicate an over-range condition whenever the terminals are open by using a 4-wire Kelvin type lead set or by shorting the V_{HI} and I_{HI} terminals together.

The display should indicate a stable reading when the test leads are securely attached to the device under test. If the display appears to be erroneous when connected to a load, recheck the test leads for integrity and cleanliness. If all external items appear to be functioning properly, the problem may be the ohmmeter. In this case, please contact your local Valhalla Scientific Sales Office.

Failsafe Operation

The Alpha 4314 Series Igniter Testers incorporate a proprietary current source design that renders them incapable of delivering excessive voltage or current to the device under test. The typical failsafe current for each range is indicated under the corresponding range LED marker on the Alpha 4314 front panel.

Every Alpha 4314 Series Igniter Tester is thoroughly tested before it leaves the factory. These tests include a failsafe test that simulates a "worst case" failure condition. The resulting output current is recorded and provided on the Certificate of Calibration included with every Alpha 4314.

As a further precaution the Alpha 4314 is isolated from the AC line whenever the POWER switch is in the ON position. The Alpha 4314 receives its power from an internal rechargeable battery pack. The Alpha 4314 must be in the OFF/CHARGING position in order to charge the batteries.

Battery Monitoring Circuitry

A standard feature of Alpha 4314 is a circuit that monitors the output voltage of the internal battery supply. The Battery Status LED for this feature is located to the far left of the display window.

- A green Battery Status LED indicate that the batteries are charged and the device can be used.
- A flashing Battery Status LED between green and red, indicates that the batteries will require recharging within the next ½ hours of continuous use. Readings are still within specified accuracies at this point.
- A Red Battery Status LED indicates that battery is low and that readings should not be trusted. An overnight recharge should be performed before using the Alpha 4314 for critical testing.

NOTE: It is possible for the user to receive a low battery indication on a single range only (particularly the 20Ω range), while the Alpha 4314 remains well within operating limits on other ranges. **Unless the user observes a continuous low battery indication during measurement, readings are still valid.**

Range Indicator LEDs

The Alpha 4314 can have 4 of 8 possible ranges. The ranges installed are indicated on the front panel by a series of lit LEDs. The range that is selected during measurement is indicated by a GREEN LED.

Chapter 6 - Troubleshooting

Malfunctions are often the result of misinterpretation of specifications or due to an incomplete understanding of the instrument. **A thorough review of the operating instructions for this instrument is recommended prior to any component replacement.** Check to be sure that cables and other test equipment are in good working order before attempting to troubleshoot the Alpha 4314.

If the Model Alpha 4314 exhibits problems that cannot be eliminated by reviewing Chapter 3 and 5, the following guidelines have been established to help solve the problem.

Localizing the Problem

The key to successful troubleshooting is to localize the problem as much as possible before trying to pin the problem down to a specific component. Certain questions should be asked such as "Does the problem occur on all ranges or on a specific range only?" The power supplies are also one of the first things that should be checked.

As it is not possible to anticipate all failure modes of the Alpha 4314, servicing personnel should become familiar with this section to gain a complete understanding of the internal workings of the Model Alpha 4314.

Component Replacement

If the problem has been identified as a faulty component, the accuracy of the Alpha 4314 can be maintained only if the following precautions are taken:

- a) Use only the specified component or its exact equivalent. Spare parts can be ordered from your nearest Valhalla Scientific Service Center or directly from the factory by referring to the Valhalla Stock Number.
- b) Use only 63/37 grade rosin core electronic grade solder with a 50W or lower maximum power soldering iron.
- c) When soldering, heat the terminal of the component, not the solder. Apply solder smoothly and evenly. Do not move the component until the solder has cooled. Bad solder joints can cause additional problems!
- d) Static sensitive parts require special handling procedures. Always treat an unknown part as if it were static sensitive.

Chapter 7 - Routine Maintenance

General

This section of the manual contains routine maintenance information regarding the Valhalla Scientific Model Alpha 4314 Digital Igniter Testers. Calibration should be performed regularly to ensure continued instrument accuracy. The recommended calibration interval is one year.

Required Test Equipment

Following is a list of the standard resistors and other equipment required to calibrate the Model Alpha 4314.

Note: The Precision Resistors necessary for the calibration of the Alpha 4314 varies based on the installed ranges.

Precision Resistors:

.1 Ω \pm 0.01% Accuracy

1 Ω \pm 0.005% Accuracy 2 Ω Range

10 Ω \pm 0.005% Accuracy 20 Ω Range

100 Ω \pm 0.005% Accuracy 200 Ω Range

1K Ω \pm 0.005% Accuracy 2k Ω Range

10K Ω \pm 0.005% Accuracy 20k Ω Range

100K Ω \pm 0.005% Accuracy 200k Ω Range

1M Ω \pm 0.005% Accuracy 2M Ω Range

10M Ω \pm 0.005% Accuracy 20M Ω Range

100M Ω \pm 0.005% Accuracy 100M Ω Range

Test Leads:

4-Wire Lead Set

(Valhalla Option "K" or "C")

Voltage Standard:

Voltage Calibrator capable of outputting from 0V to negative 150mV, 0.03% Accuracy or better.

DMM:

Model 3458A or equivalent.

Power Supply:

A power supply capable of outputting from 4.6 to 6VDC.

Calibration Procedure

VOLTAGE SENSE ADJUSTMENTS for STANDARD CURRENT MODELS

Connection:

Apply voltage at Voltage sense Input and short current source and Voltage sense negative Terminals. And select second Range

1. Apply to the Voltage Sense 0.000mV using a precision power supply.
2. Hold down switch SW7 for 1 second. LED D200 will turn on to indicate that calibration has started.
3. Press SW7 again. LED D200 will blink while the range is being calibrated.
4. Once D200 stops blinking and is ON, press SW7 again while still applying 0.000mV at Voltage Sense input. LED D200 will blink while the range is being calibrated.
5. Wait until D200 stops blinking and is ON.
6. Apply negative 15.000 mV at Voltage Sense input.
7. Press SW7. LED D200 will blink while the range is being calibrated.
8. Wait until D200 stops blinking and is ON.
9. Apply negative 150.000 mV at Voltage Sense input.
10. Press SW7. LED D200 will blink while the range is being calibrated.
11. Wait until D200 turns off.
12. Now unit should display 15000 +/-2
13. Disconnect leads.

VOLTAGE SENSE ADJUSTMENTS for KRC REDUCED CURRENT MODELS

Connection:

Apply voltage at Voltage sense Input and short current source and Voltage sense negative Terminals. And select second Range

1. Apply to the Voltage Sense 0.000mV using a precision power supply.
2. Hold down switch SW7 for 1 second. LED D200 will turn on to indicate that calibration has started.
3. Press SW7 again. LED D200 will blink while the range is being calibrated.
4. Once D200 stops blinking and is ON, press SW7 again while still applying 0.000mV at Voltage Sense input. LED D200 will blink while the range is being calibrated.
5. Wait until D200 stops blinking and is ON.
6. Apply negative 7.500 mV at Voltage Sense input.
7. Press SW7. LED D200 will blink while the range is being calibrated.
8. Wait until D200 stops blinking and is ON.
9. Apply negative 75.000 mV at Voltage Sense input.
10. Press SW7. LED D200 will blink while the range is being calibrated.
11. Wait until D200 turns off.
12. Now unit should display 15000 +/-2
13. Disconnect leads.

RESISTANCE ADJUSTMENTS

1. Select 2nd range.
2. Connect a standard resistor ½ scale of the selected range.
Example: If the 200Ω range is selected connect to a 100Ω standard resistor.
3. Adjust R15 for a display reading of “10000” (Decimal point unimportant).
4. Select Range 3rd and connect to the correspondent ½ scale standard resistor.
Example: If 2KΩ range is selected, connect to a 1KΩ standard resistor.
5. Adjust RV1 for a display reading equal to the resistor value.
6. Select Range 4th and connect to the correspondent ½ scale standard resistor.
Example: If 20KΩ range is selected, connect to a 10KΩ standard resistor.
7. Adjust RV2 for a display reading equal to the resistor value.
8. Check all remaining ranges with the appropriate standard resistors. All ranges must be within the specifications outlined in the Cal Certificate Sheet.
9. If the 20Ω range is too low select R27 using the RC Box.

IMPORTANT: If it is necessary to perform step 4.9 go back and forth between the 20Ω and 200Ω range until both are in spec.

FAILSAFE CHECK

Note: Printed next to each range indicator is the nominal fail-safe current.

1. Connect the 3458A in the ammeter mode across the current terminals. Place the Alpha 4314 in the lowest resistance range.
2. Short out the front two legs of Q4 and record the measured current level for future use.
3. Repeat this process for each range. The measured value must be less than the value indicated on the data sheet.
4. For MΩ ranges it will be necessary to connect the appropriate calibration resistor and measure the voltage drop across it. Use Ohm’s Law to calculate the failsafe current.

Range #	0	1	2	3	4	5	6	7	8
Range Value	2Ω	20Ω	200Ω	2kΩ	20kΩ	200kΩ	2MΩ	20MΩ	200MΩ
STD Fail-Safe Current	<16mA	<16mA	<1.8mA	<180μA	<18μA	<1.8μA	<180nA	<18nA	<1.8nA
KRC Fail-Safe Current	<8mA	<8mA	<1.8mA	<180μA	<18μA	<1.8μA	<180nA	N/A	N/A

LOW BATTERY & POWER-UP CHECK

1. Remove the fuse and connect a power supply at 5.4 volts across D1, observing polarity.
2. Connect a 10Ω resistor in the 20Ω range. Dial the power supply down to 4.8 volts. The "Low Battery" indicator should start changing green and red. Below 4.8V should be solid Red. If not, adjust R32 until the LED Turn RED below 4.8V. The display **must** remain stable and must not freeze up.
3. Increase the supply to 4.81 volts and note that the LED Turn Green. Return the supply to 5.4 volts.
4. Turn off the power switch and remove the load. Turn the power switch back on and reconnect the load. The reading must return to the same value as before and not freeze up.
5. Remove the power supply and replace the fuse.

Checking the Calibration Results

½ Scale and Linearity Check

Apply to each range resistor values equal to 50% of range, 5% of range, 0.5% of range and 0.05% of range.

All values should be within the tolerance specified in Chapter 3.

Zero Check

1. Apply a short between VHI and VLO.
2. Apply a short between VLO and ILO.
3. Check the display for 0 ± 3 digits

Battery Replacement Instructions

The rechargeable NiMH batteries used in the Alpha 4314 are very durable and should provide years of trouble-free operation. As with all batteries, a replacement will eventually be necessary. Batteries may be ordered from Valhalla Scientific as stock #05-10117, quantity: (4).

The process of battery replacement is described below:

Remove the four feet screws and the bottom cover.

1. Undo the reusable tie-wraps by pushing down on the locking pin.
2. Remove the old batteries and replace. Observe polarity!
3. Secure the new batteries in place by re-tightening the tie-wraps.
4. Replace the cover and feet screws, taking care not to pinch any wires.

Chapter 8 - Interface Operations

BCD Interface

Option BCD has a rear mounted 50 pin Amphenol connector providing data in a parallel binary-coded-decimal (BCD) format. The outputs are TTL compatible and may drive 1 LS load. The summary of pin functions is provided below and on the schematic number 2053-076 at the back of this manual.

Pin Number	Data
1	1
2	2
3	4
4	8
6	10
7	20
8	40
9	80
11	100
12	200
13	400
14	800
16	1000
17	2000
18	4000
19	8000
21	10000
22, 40	20000 (Over Range)
26	+5VDC Supply
50	0 VDC Common
35	End of Conversion on negative transition (A high signifies "Busy")
45	Display Hold Line (+5V or open = Run; 0V = Hold)

The BCD outputs are fully compatible with the Valhalla Model 1248 BCD Comparator. When connecting to the comparator using the standard IDC-2 interface cable, the end of the cable possessing the wire break-outs is connected to the Model 1248.

Safety Isolated RS-232 Interface

The RS-232 interface of the 4314 Series Igniter Testers is an ultra-safe isolated serial Interface. The digital signals are transmitted across the isolation barrier using iCoupler technology. The interface provides a safe way to communicate with the device via a computer or PLC and allows the transfer of single reading or continues transmission of data.

Connecting the Alpha 4314 via RS232

The RS232 interface capabilities:

The RS232 interface provides a point-to-point connection between two items of equipment such as a computer and the Alpha 4314. There are some parameters you need to set on both sides. Once you have set these parameters, you can communicate with the Alpha 4314 through the RS232 interface.

- Baud rate: 115200 baud.
- Parity bit: none.
- Data bit: 8 bits.
- Stop bit: 1 stop bit.
- Data flow control: none.

Notes for RS232 installation

The Alpha 4314 is a DCE (Data Channel Equipment) device with a 9-pin D-type shell RS232 connector located on the rear panel. Table 1 shows the 9-pin connector (Female) with its pin number assignments.

Pin #	Pin Function
1	No Connection
2	Receive Data (RxD) (input)
3	Transmit Data (TxD) (output)
4	No Connection
5	Signal Ground
6	No Connection
7	No Connection
8	No Connection
9	No Connection

Table 4 - Connector Pin Configuration

Checking Connections

To test whether the RS232 connection is working, you can send a command from the computer. For instance, using a terminal program send the query command

Idn?

The device should return the Manufacturer, model number, firmware version in the following format:

```
Valhalla Scientific Alpha4314 V2.0
```

If you do not receive a proper response from the Alpha 4314, please check if the power is on, and all cable connections are active.

COMMANDS AND SYNTAX

RS232 message terminators

As there is no signal of end message on RS232 bus, therefore, use LF, CR, or CR/LF as message terminator. After the Alpha 4314 processes a command, a CR/LF is placed in the output buffer and delivered. As for query command, the return message of the instrument is also added an LF for PC to judge message terminator.

Entering Commands

The standards that govern the command set for the Alpha 4314 allow for a certain amount of flexibility when you enter commands. The Alpha 4314 does not adhere to any friendly listening standards, so the commands and queries must be typed as specified. The Alpha 4314 is sensitive to the case of command characters. Specifically, the device uses the Camel Case.

DETAILS OF COMMAND REFERENCE

Each command in this chapter will give a detailed description. The examples of each command will be provided, and what query form might return.

Remote mode is entered when a valid printable character is received and is exited with the LOCAL front panel key or LOCAL command.

Command Index

Idn?	LogOn2	RangeV?
Local	LogOff	Reset
LogON	Ohm?	Screen?
LogOn0	Ohms?	
LogOn1	RangeN?	

Idn? QUERY

Returns the RS-232 identification string from non-volatile.

Syntax: Idn?<crlf>

Response: ID string "Valhalla Scientific Alpha4314 v2.0"

Example: Idn? "Valhalla Scientific Alpha4314 v2.0"

```
ID_STRING       :       "Valhalla Scientific"
MODEL           :       "Alpha4314"
VERSION         :       "V2.0"
```

Local **COMMAND**

Returns meter to local mode.

Syntax: Local<crLf>

Returns: <crLf>

Power-on default = LOCAL mode

Notes: REMOTE mode is selected when the meter receives a valid character (not <crLf>).

LogOn **COMMAND**

Turns on continues reading mode synonymous with "Ohms?". Note: if the devices is already Logging, the LogOn command will return "Invalid Command"

Syntax: LogOn<crLf>

Returns: Measurement Value + Multiplier every 300ms.

Example for 2Ω Range:	1.2345
Example for 20Ω Range:	12.345
Example for 200Ω Range:	123.45
Example for 2kΩ Range:	1.2345k
Example for 20kΩ Range:	12.345k
Example for 200kΩ Range:	123.45k
Example for 2MΩ Range:	1.2345M
Example for 20MΩ Range:	12.345M
Example for 200MΩ Range:	123.45M

LogOn0 **COMMAND**

Turns on continues reading mode synonymous with "Ohms?". Note: if the devices is already Logging, the LogOn0 command will return "Invalid Command"

Syntax: LogOn0<crLf>

Returns: Measurement Value + Multiplier every 500ms.

Example for 2Ω Range:	1.2345
Example for 20Ω Range:	12.345
Example for 200Ω Range:	123.45
Example for 2kΩ Range:	1.2345k
Example for 20kΩ Range:	12.345k
Example for 200kΩ Range:	123.45k
Example for 2MΩ Range:	1.2345M
Example for 20MΩ Range:	12.345M
Example for 200MΩ Range:	123.45M

LogOn1 **COMMAND**

Turns on continues reading mode synonymous with "Ohm?". Note: if the devices is already Logging, the LogOn1 command will return "Invalid Command"

Syntax: LogOn1<crLf>

Returns: Measurement Value expressed in Ohms every 500ms.

Example for 2Ω Range: 1.2345
Example for 20Ω Range: 12.345
Example for 200Ω Range: 123.45
Example for 2kΩ Range: 1234.5
Example for 20kΩ Range: 12345
Example for 200kΩ Range: 123450
Example for 2MΩ Range: 1234500
Example for 20MΩ Range: 12345000
Example for 200MΩ Range: 123450000

LogOn2 **COMMAND**

Turns on continues reading mode synonymous with "Screen? + RangeV?". Note: if the devices is already Logging, the LogOn2 command will return "Invalid Command"

Syntax: LogOn2<crLf>

Returns: Screen data + the value of the range every 500ms.

Example for 2Ω Range: 1.2345<crLf>2
Example for 20Ω Range: 12.345<crLf>20
Example for 200Ω Range: 123.45<crLf>200
Example for 2kΩ Range: 1.2345<crLf>2k
Example for 20kΩ Range: 12.345<crLf>20k
Example for 200kΩ Range: 123.45<crLf>200k
Example for 2MΩ Range: 1.2345<crLf>2M
Example for 20MΩ Range: 12.345<crLf>20M
Example for 200MΩ Range: 123.45<crLf>200M

LogOff **COMMAND**

Stops continues measurement mode.

Syntax: LogOff<crLf>

Response: <crLf>

Ohm? QUERY

Responds with the front panel reading formatted in ohms. No leading zeros.

Syntax: Ohm?<crLf>

Returns: Display data in Ohms.

Example for a 1.1 ohm reading on:

2Ω Range:	1.1000
20Ω Range:	1.100
200Ω Range:	1.10
2kΩ Range:	1.1

Ohms? QUERY

Responds with the front panel reading formatted in ohms with multiplier. No leading zeros.

Syntax: Ohms?<crLf>

Returns: Display data in Ohms with multiplier.

Example for a 1.1 ohm reading on:

2Ω Range:	1.1000
20Ω Range:	1.100
200Ω Range:	1.10
2kΩ Range:	0.0011k

RangeN? QUERY

Responds with the range number from 0 to 8

Syntax: RangeN?<crLf>

Returns: R# (0-8)

R0	-	2 Ohms Range
R1	-	20 Ohms Range
R2	-	200 Ohms Range
R3	-	2k Ohms Range
R4	-	20k Ohms Range
R5	-	200k Ohms Range
R6	-	2M Ohms Range
R7	-	20M Ohms Range
R8	-	200M Ohms Range

RangeV? QUERY

Responds with the range value from 2 to 200M

Syntax: RangeV?<crLf>

Returns: 2 - 200M

2 - 2 Ohms Range
20 - 20 Ohms Range
200 - 200 Ohms Range
2k - 2k Ohms Range
20k - 20k Ohms Range
200k - 200k Ohms Range
2M - 2M Ohms Range
20M - 20M Ohms Range
200M - 200M Ohms Range

Reset COMMAND

Executes a soft reset of the system.

Syntax: Reset<crLf>

Response: <crLf>

Screen? QUERY

Responds with the screen image.

Syntax: Screen?<crLf>

Returns: Display data formatted exactly to the screen.

Example for a 1.1 ohm reading on:

2Ω Range: 1.1000
20Ω Range: 01.100
200Ω Range: 001.10
2kΩ Range: 0001.1

Chapter 9 - Addendums

Immediately following this page may be found any notices regarding manual changes, or operating considerations for special Alpha 4314 versions. Please refer to any applicable material before attempting to operate your Model Alpha 4314.

If you have a digital copy of this manual, all available addendums are stored in a folder labeled "Alpha 4314 Series Addendums".

Note that not all of the addendums may apply to your meter.

For questions or comments, please contact:

Valhalla Scientific, Inc.
Engineering Department
12127 Kirkham Rd.
Poway California 92064

Phone: 858/457-5576
Fax: 858/457-0127
E-mail: support@valhallascientific.com

For information on our line of products, please visit our web site at:

www.valhallascientific.com

To reach our sales department:

Phone: 858/457-5576
Fax: 858/457-0127
E-mail: sales@valhallascientific.com or valhalla@valhallascientific.com

ALPHA 4314 Digital Igniter Tester User Manual
Revision # 65 Edition 3 (2019)
Copyright © 2019 Valhalla Scientific, Inc. All rights reserved

