



## Service Guide

Publication Number 54810-97067  
February 2001

This manual applies directly to oscilloscopes with serial numbers having the following prefixes:

- XX3702 through XX4106 and above

for information about serial numbers, see “Instruments Covered by this Guide” in section 1.

The part number for this Service Guide

For Safety information, Warranties, and Regulatory information, see the pages at the back of this book.

© Copyright Agilent Technologies 1997-2001  
All Rights Reserved.

---

**Agilent Models 54810A/15A/20A/25A**

---

# The Agilent Technologies Infiniium Oscilloscope at a Glance

## Ease of use with high performance

The Agilent Technologies Infiniium oscilloscopes combine unprecedented ease-of-use with high-performance digitizing oscilloscope functionality to simplify your design and analysis measurement tasks.

- Traditional oscilloscope front-panel interface provides direct access to the controls needed for most troubleshooting tasks
- Graphical user interface with menus, windows, dialogs, and toolbars provides easy access to dozens of configuration and analysis tools, ensuring you can set up and make the most complex measurements

## Different scopes to meet your needs

- 54810A with 2 channels, 1 GSa/s sampling rate, 500 MHz bandwidth
- 54815A with 4 channels, 1 GSa/s sampling rate, 500 MHz bandwidth
- 54820A with 2 channels, 2 GSa/s sampling rate, 500 MHz bandwidth
- 54825A with 4 channels, 2 GSa/s sampling rate, 500 MHz bandwidth

## Display shows waveforms and graphical user interface

- Graphical interface allows direct interaction with waveforms, including drag-and-drop positioning and instant waveform zoom
- Waveforms displayed in color, making correlation easy
- Current configuration parameters displayed near the waveform display and are color-coded to make identification easy
- Graphical interface menus and toolbars simplify complex measurement setups

## Horizontal controls set sweep speed and position

- Main sweep speeds from 500 ps/div to 5 s/div
- Delayed sweep speeds from 100 ps/div to main time base setting
- Intensified waveforms on main sweep window make it easy to see what will appear in delayed sweep window

## Acquisition and general controls start and stop the scope and do basic setup

- Run and stop controls for continuous or single-shot acquisitions
- Clear display before one or more acquisitions
- Default setup and Autoscale set initial configuration

## Hard disk drive and floppy disk drive for saving and restoring setups and measurement results

- Store measurement displays for inclusion in reports and test setup guides
- Store oscilloscope setups to repeat tests another time
- Hard disk stores oscilloscope operating system

## Trigger setup controls set mode and basic parameters

- Select Edge, Glitch, or Advanced Modes
- Choose input source and slope
- Set coupling for trigger
- Use graphical user interface to simplify configuration of pattern, state, delay, violation, and video triggers
- Use External trigger (two-channel models) and auxiliary trigger in (four-channel models) to increase triggering flexibility

## Vertical controls set input coupling, impedance, attenuation, and position

- AC or DC input coupling
- 1 M $\Omega$  or 50 $\Omega$  input impedance
- Input attenuation adjustable from 1 mV/div to 5 V/div
- Color-coded knobs make it easy to find the controls that affect each waveform

## Marker and quick measurements help measure waveform parameters

- Waveform markers A and B to check voltage or  $\Delta$ -time at any point on the displayed waveform
- Quick Meas executes up to four predefined measurements instantly

## Service Policy

The service policy of this instrument requires replacing defective assemblies. Some assemblies can be replaced on an exchange basis. Items such as the vertical attenuators, which are subject to wear and tear based on frequency of use, are a maintenance item that may need occasional replacement.

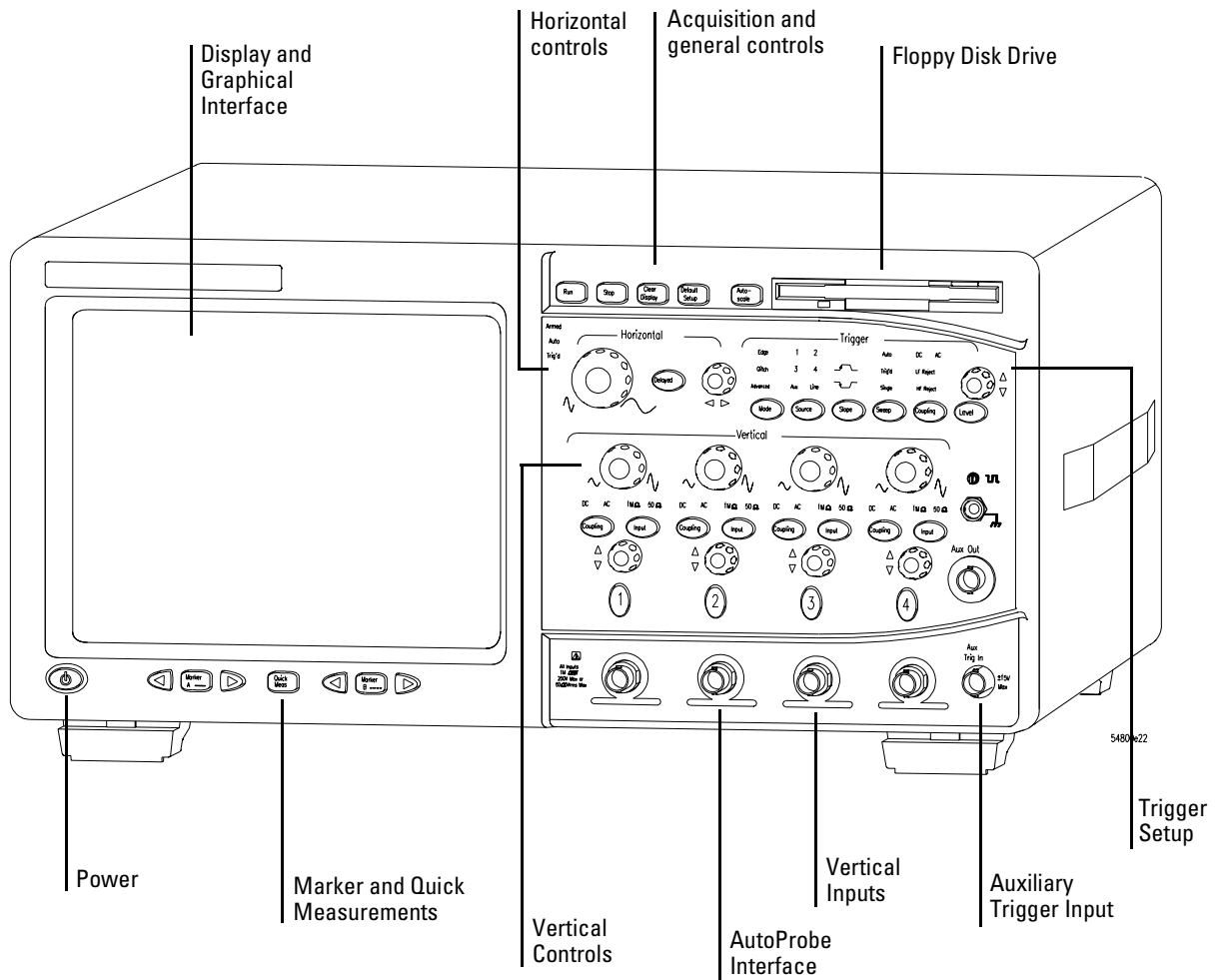

---

## In This Book

This book provides service documentation for the Agilent Technologies 54810A/15A/20A/25A oscilloscopes. It is divided into eight chapters.

Chapter 1 provides general information and specifications.

Chapter 2 shows you how to prepare the oscilloscopes for use.

Chapter 3 gives performance tests.

Chapter 4 covers calibration and adjustment procedures, how to do them, and how often they need to be done.

Chapter 5 provides troubleshooting information.

Chapter 6 gives the procedures and techniques for replacing assemblies and other parts.

Chapter 7 includes a list of exchange assemblies and other replaceable parts, part ordering information, and shipping information.

Chapter 8 briefly covers the internal operation of the oscilloscopes.

At the back of the book you will find Safety information, Warranties, and Regulatory information.

---

# Contents

## Contents 1

### 1 General Information 1-2

- Instruments covered by this service guide 1-2
- Accessories supplied 1-3
- Options available 1-4
- Accessories available 1-5
- Specifications & characteristics 1-7
- Agilent Technologies 54810A/15A/20A/25A general characteristics 1-14
- Recommended test equipment 1-16

### 2 Preparing for Use 2-2

- Setting Up the Oscilloscope 2-3
  - To inspect the instrument 2-3
  - To connect power 2-4
  - To connect the mouse or other pointing device 2-5
  - To attach the optional trackball 2-5
  - To connect the keyboard 2-7
  - To connect to the LAN card 2-7
  - To connect oscilloscope probes 2-8
  - To connect a printer 2-9
  - To connect an external monitor 2-10
  - To connect the GPIB cable 2-10
  - To tilt the oscilloscope upward for easier viewing 2-11
  - To power on the oscilloscope 2-12
  - To verify basic oscilloscope operation 2-13
  - To clean the instrument 2-14
  - To clean the display monitor contrast filter 2-14

### 3 Testing Performance 3-2

- Testing Interval 3-2
- Equipment Required 3-2
- Self-Test Verification 3-2
- Test Record 3-3
- Operating Hints 3-3
- Specifications 3-3
- Performance Test Procedures 3-3
  - To test the dc calibrator 3-4
  - To test input resistance 3-6
  - To test voltage measurement accuracy 3-7
  - To test offset accuracy 3-11
  - To test bandwidth 3-13
  - To test time measurement accuracy 3-15
  - To test trigger sensitivity 3-22

### 4 Calibrating and Adjusting 4-2

- Equipment Required 4-2
- Self Calibration Interval and Hardware Adjustments 4-2

## Contents

- Mainframe Cal Factor Memory Error 4-2
- Operating Hints 4-3
- Loading Default Instrument Settings 4-3
- Loading New Software 4-3
- Calibration and Adjustment Procedures 4-3
  - To check the power supply 4-4
  - To check the 715 Hz auxiliary output (probe compensation square wave) 4-5
  - To check the flat panel display (FPD) 4-6
  - To adjust the high-frequency pulse response 4-9
  - To run the self-calibration 4-11

## 5 Troubleshooting 5-2

- Safety 5-2
- Tools Required 5-2
- ESD Precautions 5-2
- Keystroke Conventions 5-2
- Default Setup 5-3
  - To install the fan safety shield 5-3
  - To troubleshoot the instrument 5-3
- Primary Trouble Isolation 5-5
  - No Display Trouble Isolation 5-8
  - Power Supply Trouble Isolation 5-12
    - To check probe power outputs 5-15
    - To check the keyboard 5-16
    - To check the LEDs 5-18
    - To check the motherboard, CPU, and RAM 5-20
    - To check the SVGA display board video signals 5-21
    - To check the backlight inverter voltages 5-22
  - POST Code Listing (AMI Motherboard only) 5-23
    - To configure the motherboard jumpers and set up the BIOS 5-28
    - To troubleshoot the acquisition system 5-46
    - To troubleshoot attenuator failures 5-53
- Software Revisions 5-55

## 6 Replacing Assemblies 6-2

- ESD Precautions 6-2
- Tools Required 6-2
  - To return the instrument to Agilent Technologies for service 6-3
  - To remove and replace the cover 6-4
  - To disconnect and connect Mylar flex cables 6-5
  - To remove and replace the AutoProbe assembly 6-6
  - To remove and replace the probe power and control assembly 6-8
  - To remove and replace the backlight inverter board 6-9
  - To remove and replace the front panel assembly 6-9
  - To remove and replace the keyboard, flat-panel display, and backlight assemblies 6-12
  - To remove and replace the acquisition board assembly 6-14
  - To remove and replace the LAN interface board 6-16
  - To remove and replace the GPIB interface board 6-16
  - To remove and replace the scope interface board and SVGA display board 6-17
  - To separate the scope interface board and SVGA display board 6-18
  - To remove and replace the Option 200 sound card 6-19

- To remove and replace the hard disk drive 6-20
- To remove and replace the floppy disk drive 6-21
- To remove and replace the motherboard 6-21
- To remove and replace the power supply 6-23
- To remove and replace the fan 6-24
- To remove and replace the CPU 6-25
- To remove and replace RAM SIMMs or SDRAM DIMMs 6-26
- To remove and replace an attenuator 6-27
- To reset the attenuator contact counter 6-29
- To remove and replace an acquisition hybrid 6-31

**7 Replaceable Parts 7-2**

- Ordering Replaceable Parts 7-2
- Power Cables and Plug Configurations 7-3
- Exploded Views 7-4
- Replaceable Parts List 7-15

**8 Theory of Operation 8-3**

- Block-Level Theory 8-3
- Attenuator and Preamp Theory 8-7
- Acquisition Theory 8-7





Instruments covered by this service guide	1-2
Accessories supplied	1-3
Options available	1-4
Accessories available	1-5
Specifications & characteristics	1-7
Agilent Technologies 54810A/15A/20A/25A general characteristics	1-14
Recommended test equipment	1-16

---

# General Information

This chapter of the Agilent Technologies Infiniium Oscilloscopes Service Guide gives you general information about the instrument. The following topics are covered in this chapter.

- Instrument identification
- Options
- Accessories
- Specifications and characteristics
- Test equipment requirements

---

## Instruments covered by this service guide

On the rear panel of the instrument is a serial number label and a VIN # label. The serial number is in the form of XX00000000 while the VIN # is in the form of VIN # 0XX. The serial number is composed of two parts: the first two letters and the first four numbers are the serial prefix, while the last four numbers are the suffix. The prefix is normally the same for all identical oscilloscopes and changes only when a change has been made to the oscilloscope. However, the suffix is sequentially assigned and is different for each oscilloscope. The contents of this manual applies to oscilloscopes with serial number prefixes listed on the title page.

An oscilloscope manufactured after the printing of this manual may have a newer serial number prefix. This newer serial prefix indicates that the oscilloscope may be different from those described in this manual. The manual for this oscilloscope will be revised as needed. If you have an oscilloscope with a newer serial prefix, please refer to the Agilent Technologies website and download a newer manual edition in Adobe Acrobat (pdf) format. The Agilent Technologies URL is: “[www.agilent.com](http://www.agilent.com)”. It will be necessary to search on a key word such as “Infiniium Service Guide”, and follow the links.

For additional information on configuration differences see the following sections in this service guide:

- “To configure the motherboard jumpers and setup the BIOS” in the Troubleshooting section 5 for information on determining:
  - which computer configuration is contained in your oscilloscope
  - setting up the BIOS correctly for that configuration
  - setting the motherboard jumpers if the PC motherboard is changed.
- Replaceable Parts section 7.

This section contains exploded views for the different motherboard configurations, cabling schemes, and outside hardware versions. The Replaceable Parts List also contains the assembly part numbers for the different oscilloscope configurations.

Table 1-1

**Oscilloscopes Covered by this Service Guide**

Model	Description
Agilent 54810A	Two-channel digitizing oscilloscope with 1 GSa/s sample rate, 500 MHz bandwidth
Agilent 54815A	Four-channel digitizing oscilloscope with 1 GSa/s sample rate, 500 MHz bandwidth
Agilent 54820A	Two-channel digitizing oscilloscope with 2 GSa/s sample rate, 500 MHz bandwidth
Agilent 54825A	Four-channel digitizing oscilloscope with 2 GSa/s sample rate, 500 MHz bandwidth

Each oscilloscope can be identified by the product number appearing on the back panel. See the *Infiniium Oscilloscope Service Guide for the Agilent Model 54835A/45A/46A* for information on the 54835A, 54845A, and 54846A.

**Accessories supplied**

The following accessories are supplied.

- Mouse, P/N C3751-60201
- Mouse Pad, P/N 54810-85903
- Keyboard (E2610A)
- (2) 1160A 10:1 10 M $\Omega$  passive probes (Agilent 54810A, 54820A)
- (4) 1160A 10:1 10 M $\Omega$  passive probes (Agilent 54815A, 54825A)
- User's Hard Drive Recovery Disks
- Accessory Pouch (P/N 54810-68701)
- 1 US Power cord (see chapter 7, "Replaceable Parts," for available power cords)
- *User's Quick Start Guide*
- *Programmer's Guide* and *Programmer's Quick Reference*
- *Infiniium Oscilloscopes Service Guide for Agilent Models 54810A/15A/20A/25A*

---

## Options available

The following options are available for the Infiniium oscilloscopes.

**Table 1-2**

---

### Infiniium Oscilloscope Options

---

<b>Option Number</b>	<b>Description</b>
090	Delete standard probes
001	Add 2 standard probes—Agilent 1160A probes for the 54810A/15A/20A/25A
002	Add 1 Agilent 1162A 1:1 passive probe
003	Add 1 Agilent 1163A 10:1 500 $\Omega$ , low-C passive probe
008	Add 1 Agilent 1153A 200 MHz differential probe
100	Communication Mask Test Kit
1BP	MIL-STD-45662A and ANSI/NCSS Z540 calibration with test data
1CM	Add 1 Rackmount kit (E2609A)
200	VoiceControl Option
UL6	Add 1 Clip-on trackball pointing device (E2611A)
UL5	Add 1 touchpad pointing device (E2612A)
W32	3 years calibration service
W34	3 years return standards comp cal service
W50	5 years return repair service (additional 2 years)
W52	5 years return calibrations service
W54	5 years return standards comp cal service

Other options are available. See your Agilent Technologies Sales Representative. You can order multiple options, or you can order most of these options separately, using the model number or part number.

---

## Accessories available

The following accessories are available for use with the Infiniium oscilloscopes.

**Table 1-3**

---

### Accessories for the Infiniium Oscilloscopes

---

Agilent 1144A	800 MHz Active Probe Requires Agilent 1142A power supply—1144-61604 probe power extender also required when using 2 or more Agilent 1144A active probes
Agilent 1144-61604	Power Probe Extender
Agilent 1145A	2-channel 750 MHz SMT active probe Requires Agilent 1142A power supply
Agilent 1146A	Oscilloscope AC/DC Current Probe
Agilent 1152A	2.5 GHz, 10:1, 100 k $\Omega$ , 0.6 pF Active Probe
Agilent 1153A	200 MHz Differential Probe
Agilent 1155A	750 MHz 2-Channel, Low-Mass Active Probe
Agilent 1160A	Standard probes for the Agilent 54810A/15A/20A/25A
Agilent 1162A	1:1 Passive Probe
Agilent 1163A	10:1 500- $\Omega$ , low-C Passive Probe
Agilent 1170A	500 MHz Low-Mass, Miniature 10:1 10 M $\Omega$ Passive Probe
Agilent 1171A	500 MHz Low-Mass, Miniature 10:1 10 M $\Omega$ Passive Probe
Agilent 1172A	500 MHz Low-Mass, Miniature 20:1 10 M $\Omega$ Passive Probe
Agilent 1173A	500 MHz Low-Mass, Miniature 20:1 10 M $\Omega$ Passive Probe
Agilent 1182A	Testmobile
Agilent 10020A	Resistive Divider Probe Kit
Agilent 10240B	BNC Blocking Capacitor
Agilent 10833A	GPIB cable, 1 m
Agilent 10833B	GPIB cable, 2 m
Agilent 10833C	GPIB cable, 4 m
Agilent 10833D	GPIB cable, 0.5 m
Agilent 11094B	75 $\Omega$ Feedthrough Termination
Agilent 34398A + Agilent 34399A	RS-232-C printer cable + adapter kit
Agilent 54006A	6 GHz, 10:1 (500 $\Omega$ ) or 20:1 (1 k $\Omega$ ), .25 pF
Agilent 01144-61604	1:2 probe power fan-out (for use with Agilent 1144A and 1145A)
Agilent C2950A	Parallel printer cable, 2 m
Agilent C2951A	Parallel printer cable, 3 m
Agilent 54810-68703	Service Kit (includes service software and fan safety shield)
Agilent E2610A	Keyboard
Agilent E2609A	Rackmount Kit
Agilent E2611A	Clip-on track ball pointing device
Agilent E2612A	Touchpad pointing device

---

Chapter 1: General Information  
**Accessories available**

---

Agilent E2625A	Communication Mask Test Kit
Agilent 54801-00601	Fan Safety Shield (clips onto side of chassis with cover removed); part of Service Kit.
Agilent E2635A	Voice Control Retrofit Kit
Agilent E2636A	Microphone Replacement

## Specifications & characteristics

The following tables list the performance specifications and operating characteristics for the Agilent 54810A/15A/20A/25A oscilloscopes. Asterisks (\*) denote warranted specifications, all others are typical. Specifications are valid after a 30-minute warm-up period, and within  $\pm 10$  °C from the self-calibration temperature.

### Acquisition

	Maximum Sample Rate	Real Time	Agilent 54810A/54815A: 1 GSa/s on each channel Agilent 54820A/54825A: 2 GSa/s on each channel
	Maximum Effective Sample Rate	Equivalent Time	100 GSa/s
	Memory Depth	32,768 points/channel	
	Memory Depth Modes	Auto	Optimized for best combination of update rate and display quality.
		Manual	Selectable from 16 to 32,768 points in increments of 1 point.
	Sampling Modes	Real Time	Successive single shot acquisitions.
		Equivalent Time	Random repetitive sampling (higher time resolution at fast sweep speeds).
		Peak Detect	Captures and displays narrow pulses or glitches 1 ns or wider at sample rates of 250 MSa/s or less.
	Filters	9-bit Bandwidth Limit filter: $BW = (\text{Sample Rate})/20$  (Sin x)/x Interpolation: On/Off selectable FIR digital filter. Digital signal processing adds points between acquired data points to enhance measurement accuracy and waveform display quality. BW= Sample Rate/4	
	Averaging	Selectable from 2 to 4096.	

---

**Vertical**

---

Number of Channels	Agilent 54810A/20A: 2 (simultaneous acquisition) Agilent 54815A/25A: 4 (simultaneous acquisition)	
Bandwidth	Analog Bandwidth (-3dB)*	500 MHz
	System Bandwidth	Agilent 1160A 10:1 passive probe: 500 MHz Agilent 1162A 1:1 passive probe: 25 MHz Agilent 1163A 10:1, 500 Ω passive probe: 500 MHz Agilent 1152A 2.5 GHz, 0.6 pF active probe: 500 MHz Agilent 1153A 200 MHz differential probe: 200 MHz
	Real Time bandwidth*	Agilent 54810A/54815A: 250 MHz Agilent 54820A/54825A: 500 MHz
Rise Time <sup>1</sup>	Agilent 54810A/15A: 700 ps (Equivalent Time), 1.4 ns (Real Time) Agilent 54820A/25A: 700 ps	
Sensitivity <sup>2</sup>	1 MΩ Coupling: 1 mV/div to 5 V/div 50 Ω Coupling: 1 mV/div to 5 V/div	
Input Impedance*	1 MΩ ± 1% (≅8 pf), or 50 Ω ± 1%	
Input Coupling	dc, ac (7 Hz, available in 1 MΩ only)	
Maximum Input Voltage	1 MΩ: ±250 V (dc + ac) [ac<10 kHz], CAT I 50 Ω: 5 V <sub>rms</sub> , CAT I	
Hardware Bandwidth Limit (-3 dB)	On/Off selectable, 30 MHz	
Channel-to-channel Isolation (with channels at equal sensitivity)	dc to 50 MHz: 50 dB 50 MHz to 500 MHz: 40 dB	
Offset Range	Vertical Sensitivity	Available Offset
	1 mV to 49 mV/div	± 2 V
	> 49 mV to 249 mV/div	± 10 V
	> 249 mV to 1.24 V/div	± 50 V
	> 1.24 V to 5.0 V/div	± 250 V
Full-resolution channel scales	All volts/division settings ≥ 7 mV/div	
Dynamic Range	± 12 div from center screen	
dc Gain Accuracy <sup>*2,3</sup>	± 1.25% of full scale at full resolution channel scale.	
Resolution <sup>2</sup>	Real Time	8 bits (0.4% of full scale), 12 bits with averaging (0.024% of full scale)
	Equivalent Time	8 bits (0.4% of full scale), 12 bits with averaging (0.024% of full scale)
Offset Accuracy <sup>*2</sup>	± (1.25% of channel offset + 2% of full scale) at full-resolution channel scale.	
dc Voltage Measurement Accuracy <sup>*2,3</sup>	Dual Cursor	±[(dc gain accuracy)+(resolution)] (When averaging is off, this is equivalent to: ± (1.25% of full-resolution channel scale + 0.4% of full scale). When averaging is on, this is equivalent to: ± (1.25% of full-resolution channel scale + 0.024% of full scale) after 32 averages.)



dc Voltage Measurement Accuracy (Cont'd)	Single Cursor	$\pm[(\text{dc gain accuracy})+(\text{offset accuracy})+(\text{resolution}/2)]$ (When averaging is off, this is equivalent to: $\pm(1.25\%$ of full-resolution channel scale + offset accuracy + 0.2% of full scale). When averaging is on, this is equivalent to: $\pm(1.25\%$ of full-resolution channel scale + offset accuracy + 0.012% of full scale) after 32 averages.)
--	---------------	--



**AutoProbe Interface**

AutoProbe is an intelligent communication and power link between compatible probes and Infiniium scopes. AutoProbe completely configures the scope for the attached probe. For instance, it identifies the probe type and sets up the proper input impedance, attenuation ratio, probe power and offset range, as needed.

**Horizontal**

Main Time Base Range	500 ps/div to 20 s/div	
Horizontal Position Range	pretrigger	0 to -1 s or one full screen width, whichever is larger.
	posttrigger	0 to 1 s or one full screen width, whichever is larger.
Delayed Sweep Range	1 ps/div to current main time base setting.	
Delayed Sweep Delay Range	Within main time base acquisition record.	
Resolution	10 ps	
Timebase Accuracy	50 ppm (.005%)	
$\Delta t$ Accuracy*	Real Time mode <sup>4</sup>	$\pm[(.005\%)(\Delta t)+(0.2)(\text{sample period})]$
	Equivalent Time mode	$\pm[(.005\%)(\Delta t)+(\text{full scale}/(2 \times \text{memory depth})) + 60 \text{ ps}]$ (Example: for $\geq 16$ avgs, 9 ns signal, 1 ns/div, 1 channel, then accuracy = $\pm[(.005\%)(9 \text{ ns})+(10 \text{ ns}/(2 \times 32,768)) + 60 \text{ ps}] = 61 \text{ ps}$ )
	Peak Detect Acq. mode	$\pm[(.005\%)(\Delta t)+(1 \text{ sample period})]$

Chapter 1: General Information  
**Specifications & characteristics**

---

**Trigger**

---

Sensitivity*2	dc to 100 MHz	100 MHz to 500 MHz
Internal (normal)	0.5 div	1.0 div
Internal (noise reject)	1.0 div	1.5 div
External (Agilent 54810/20A)	0.0225 x (signal range)	0.045 x (signal range)
Auxiliary (Agilent 54815/25A)	dc to 500 MHz: 300 mV <sub>pp</sub>	
Maximum Input Voltage*	External (Agilent 54810/20A)	1 MΩ: ± 250 V (dc + ac) [ac < 10 kHz], CAT I 50 Ω: 5 V <sub>rms</sub> , CAT I
	Auxiliary (Agilent 54815/25A)	± 15 V, CAT I
Minimum Pulse Width (internal, external)	1 ns at > 1.0 div	
Level Range	Internal	± 12 div from center screen
	External (Agilent 54810/20A)	± 1 V, ± 5 V, ± 25 V
	Auxiliary (Agilent 54815/25A)	± 5 V
Sweep Modes	Auto, triggered, single	
Trigger Coupling	dc, ac (7 Hz), low-frequency reject (50 kHz), high frequency reject (50 kHz).	
Trigger Holdoff Range	60 ns - 320 ms	
Trigger Modes	Edge, Glitch, Pattern, State, Delay by Time, Delay by Events, Violation (Setup/ Hold Time, Pulse Width, Transition), Video, Line.	
Glitch	Select positive or negative polarity, width. Captures glitches as narrow as 500 ps.	
Pattern	Select inputs as High, Low or X (don't care) to create pattern. Trigger when pattern is entered, exited, present >t, present <t, or present over a range of time. Captures patterns as narrow as 500 ps.	
State	Select one channel as clock, specify other inputs as High, Low or X. Logic Type: AND or NAND	
Delay by Time	Time: 30 ns to 160 ms. The trigger is qualified by an edge. After the delay, a rising/falling edge on any one selected input will generate the trigger.	
Delay by Events	Events: 1 to 16,000,000 rising or falling edges. The trigger is qualified by an edge. After the delay, a rising/falling edge on any one selected input will generate the trigger.	
Violation Trigger	Setup/Hold	Modes: Setup, Hold or Setup and Hold. Select Clock, Thresholds, setup and/or hold time.
	Pulse Width	Triggers on pulse width >t, or <t. Captures pulses as narrow as 500 ps.
	Transition	Select Rise Time or Fall Time, present >t or present <t, thresholds.
Accuracy (time) for glitch, pulse width, and time-qualified pattern	1.5 ns - 20 ns: ±(20% setting + 500 ps) 20 ns - 160 ms: ±(3 % setting + 2 ns)	
Video Triggering	525 lines/60 Hz (NTSC), 625 lines/50 Hz (PAL), 875 lines/60 Hz. Trigger on Field 1 or Field 2, any line. User defined triggering: User can specify sync pulse level, width and polarity, edge number.	

<b>Display</b>		
Display	8.4-inch diagonal color active matrix LCD module incorporating amorphous silicon TFTs.	
Active Display Area	171mm x 128 mm (21,888 sq. mm)	
Waveform Viewing Area	104 mm x 159 mm (16,536 sq. mm) in Full screen mode (graphical user interface off)	
Display Resolution	640 pixels horizontally x 480 pixels vertically	
Waveform Colors	Select from 100 hues, 0-100% saturation and 0-100% luminosity.	
Dual Intensity Infinite Persistence	Previous sweeps are stored in half bright display and most recent sweep in full bright. This allows easy differentiation of current and historic information.	
Waveform Overlap	When two waveforms overlap, a third color distinguishes the overlap area.	
Full screen mode	On/Off selectable.	
Connect-the-dots	On/Off selectable.	
Persistence	Minimum, Variable (100 ms to 40 s), Infinite. Up to 6 levels of grey scale.	
Graticule	On/Off (Grid or Frame).	
Grid Intensity	0 to 100%	
Display Update Rate (for instruments equipped with AMD-K6-2™400 MHz processors)	Measurement Conditions	Real Time sampling mode, minimum persistence, triggered sweep, no interpolation, markers off, math off, connect the dots off, 1 channel acquisition, 50 ns/div, statistics off.
	512 point record (2 GSa/s)	Waveforms/sec: > 2,100 V <sub>pp</sub> Measurements/sec: > 130

<b>Measurements</b>		
Automatic Parametrics	33 automatic measurements: V <sub>pp</sub> , V <sub>min</sub> , V <sub>max</sub> , V <sub>avg</sub> , V <sub>amptd</sub> , V <sub>base</sub> , V <sub>top</sub> , V <sub>rms</sub> , Preshoot, Overshoot, V <sub>upper</sub> , V <sub>middle</sub> , V <sub>lower</sub> , Rise Time, Fall Time, Period, Frequency, Positive Width, Negative Width, Duty Cycle, Delta Time, T <sub>max</sub> , T <sub>min</sub> , FFT Frequency, FFT Magnitude, FFT Delta Frequency, FFT Delta Magnitude, Eye Height, Eye Width, Jitter, Crossing %, Q-factor, Duty Cycle Distortion. Over GPIB only: VTime, TVolts.	
	Threshold Definition	Selectable 10%, 50%, 90% or 20%, 50%, 80% or Custom (% or absolute voltage).
	Top-Base Definition	Standard or Custom (in absolute voltage).
	Statistics	On/Off selectable. Current measurement, mean, and standard deviation
Measurement Toolbar	16 Drag and Drop automatic measurement icons.	
QuickMeas	Activates 4 preselected automatic measurements.	
Markers Modes	Manual Markers, Track Waveform Data, Track Measurements.	
Waveform Math	4 function waveforms f1-f4. Select from Add, Subtract, Multiply, Divide, Invert, Magnify, Vs, Min, Max, Integral, Differentiate, FFT Magnitude.	

Chapter 1: General Information  
**Specifications & characteristics**

---

**FFT**

Frequency Range <sup>5</sup>	Agilent 54820A/54825A Agilent 54810A/54815A	dc to 1 GHz (Sample rate/2) dc to 500 MHz (Sample rate/2)
Frequency Resolution		
Best Resolution	15.3 $\mu$ Hz (Sample rate <sub>min</sub> /32,768 pts)	
Best Resolution at SR <sub>max</sub>	Agilent 54820A/54825A Agilent 54810A/54815A	61.0 kHz (Sample rate <sub>max</sub> /32,768 pts) 30.5 kHz (Sample rate <sub>max</sub> /32,768 pts)
Freq. Accuracy	(1/2 frequency resolution)+(5x10 <sup>-5</sup> )(signal frequency)	
Amplitude Display	Power in dBm	
Signal-to-noise ratio	70 dB at 32K memory depth. Noise floor varies with memory depth and with averaging.	
Window Modes	Hanning, Flattop, Rectangular.	

---

**Computer System/ Storage**

CPU	AMD-K5™ PR133 Microprocessor (instrument serial numbers US37349999 and below) or AMD-K6™ 200 MHz Microprocessor or AMD-K6/300™ or AMD-K6-2/300™ 300 MHz Microprocessor	
Disk Drive	1.4 GByte, 2.1 GByte, or higher internal hard drive depending upon the vintage. Storage capacity is limited only by disk space. 3.5", 1.44 Mbyte MS-DOS™-compatible high density floppy disk drive or LS-120 MS-DOS 120 MByte floppy disk drive.	Store and recall setups, waveforms, and store screen images to both the hard drive and the floppy drive.
File types	Waveforms	Internal Y values; X and Y values in ASCII or Microsoft Excel formats.
	Images	BMP, EPS, GIF, PCX, PS (Postscript), TIF.
Mouse	Standard mouse supplied—supports any Microsoft® mouse compatible pointing device, serial or PS/2.	
Operating System	Microsoft Windows 95 or Microsoft Windows 98	
Waveform Memories	4 nonvolatile waveform reference memories.	

---

**I/O**

LAN	Enables data/setup file transfers and use of network printers; supports popular network operating systems including Novell NetWare, Microsoft, Banyan VINES, SCO UNIX and IBM; 10 Mbps operation that complies with IEEE 802.3 Ethernet and ISO/IEC 8802-3 Ethernet standards; TCP/IP protocol; and RJ-45.	
GPIB	Fully programmable, complies with IEEE 488.2.	
RS-232 (serial)	2 ports: COM1, COM2. Printer and pointing device support.	
Centronics	ECP parallel communication, configurable only as a printer port.	
USB	Two pinheads link with Universal Serial Bus connectors (USB1 and USB2) peripheral devices via either a dual-port USB cable or a single-port USB cable on some configurations with serial prefixes US39480000 and above.	
Printers and Plotters	Supports all printers and plotters compatible with Microsoft Windows95®. Includes but is not limited to Hewlett-Packard Deskjet and Laserjet series printers. GPIB devices not supported.	

---

PS/2 port	For PS/2 mouse.
Keyboard port	For optional keyboard.
Video Output	15 pin VGA, full color.

---

**Notes**

---

- 1 Rise Time figures are calculated from :  $tr = .35 / \text{Bandwidth}$ .
- 2 Magnification is used below 7 mV/div range. Below 7 mV/div, full scale is defined as 56 mV.
- 3 The dc gain accuracy decreases 0.08% of full scale per degree C from the firmware calibration temperature.
- 4 For bandwidth limited signals,  $tr \geq 1.4 \times \text{sample interval}$ .
- 5 FFT amplitude readings are affected by input amplifier roll-off (-3 dB at 500 MHz, with amplitude decreasing as frequency increases above 500 MHz).

**CAT I and CAT II Definitions**

Installation category (overvoltage category) I: Signal level, special equipment or parts of equipment, telecommunication, electronic, etc., with smaller transient overvoltages than installation category (overvoltage category) II.

Installation category (overvoltage category) II: Local level, appliances, portable equipment, etc., with smaller transient overvoltages than installation category (overvoltage category) III.

---

## Agilent Technologies 54810A/15A/20A/25A general characteristics

The Infiniium oscilloscopes meet the Agilent Technologies Environmental Specification (section 750) for class B-1 products with exceptions as described for temperature.

---

### General Characteristics

Environmental	Temperature	Operating: 0°C to +50°C Nonoperating: -40°C to 70°C Indoor use only
	Humidity	Operating: Up to 95% relative humidity (noncondensing) at +40°C Nonoperating: Up to 90% relative humidity at +65°C
	Altitude	Operating: Up to 4 600 meters Nonoperating: Up to 15 300 meters
	Vibration	Operating: Random vibration 5-500 Hz, 10 minutes per axis, 0.3g (rms) Nonoperating: Random vibration 5-500 Hz, 10 minutes per axis, 2.41g (rms)  Resonant search 5-500 Hz, swept sine, 1 octave/minute sweep rate, (0.75g), 5-minute resonant dwell at 4 resonances per axis.
Physical	Size (excluding handle)	Height: 216 mm Width: 437 mm Depth: 440 mm
	Weight	Net: approximately 10.6 kg Shipping: approximately 13.6 kg
Power	Line voltage selection	None, PFC (Power Factor Correction)
	Line voltage range	100-240VAC, ± 10% CAT II
	Line frequency	47 to 440 Hz
	Maximum power consumption	390 W
Safety	Meets IEC1010-1 +A1, CSA certified to C22.2 No. 1010.1, Self certified to UL 3111.	

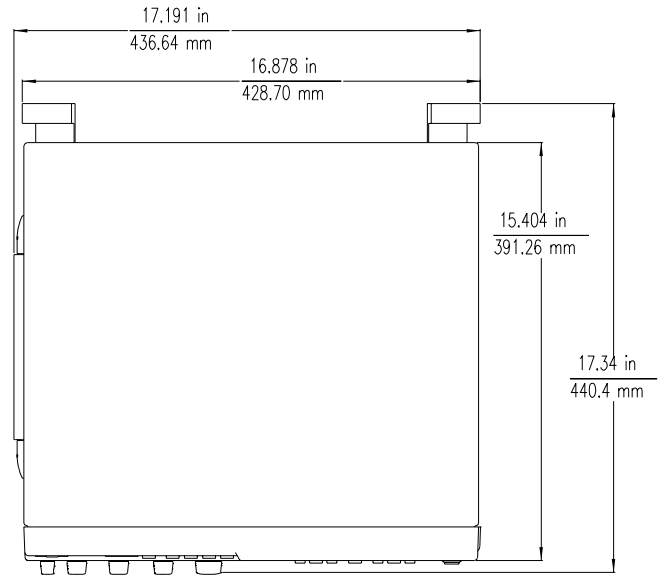
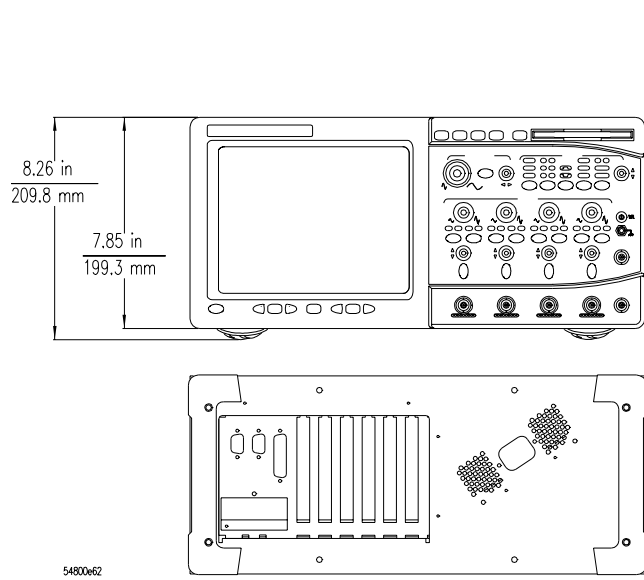

## Recommended test equipment

The following table is a list of the test equipment required to test performance, calibrate and adjust, and troubleshoot this instrument. The table indicates the critical specification of the test equipment and for which procedure the equipment is necessary. Equipment other than the recommended model may be used if it satisfies the critical specification listed in the table.

### Recommended Test Equipment

Equipment Required	Critical Specifications	Recommended Model	Use *
Signal Generator	1 - 500 MHz, sine wave, amplitude 30 - 200 mV <sub>rms</sub> , time base accuracy 0.25 ppm	Agilent 8656B, Opt 001	P
RF Amplifier	22 dB gain at 10 MHz, 1.3 GHz bandwidth	Agilent 8447D/F	P
Power Meter/Power Sensor	1 - 500 MHz, -70 dBm to +44 dBm, ±3% accuracy	Agilent EPM-441A / Agilent 8482A	P
DMM	6 1/2 digit (0.1 mV) resolution, dcV accuracy 8 ppm/year, 4-wire resistance acc. ±0.25%	Agilent 34401A	P, A, T
Power Supply	7 mV - 30 V dc, 0.1 mV accuracy and resolution	Agilent 6114A	P
Pulse Generator	t <sub>r</sub> < 175 ps	Picosecond Pulse Labs 1110B Driver, 1107B Head	A
Power Splitter	50 Ω type N, outputs differ by <0.15 dB	Agilent 11667A	P
Oscilloscope	General-purpose	Agilent 54622A	P, T
Blocking Capacitor	0.18 μF	Agilent 10240B	P
Cable	Type N (m)(m) - 3 foot	Agilent 11500A or B	P
Cable (2)	BNC - 3 foot	Agilent 10503A	P, A, T
Cable (3)	BNC - 9 inch	Agilent 10502A	P, A, T
Adapter	N (m) to BNC (m)	Agilent 1250-0082	P
Adapter	N (m) to BNC (f)	Agilent 1250-0780	P
Adapter	N (f) to BNC (m)	Agilent 1250-0077	A
Adapter	SMA (m) to BNC (m)	Agilent 1250-1787	A
Adapter (2)	BNC tee (m)(f)(f)	Agilent 1250-0781	P, T
Adapter	BNC (f)(f)	Agilent 1250-0080	T
Adapter (2)	BNC (f) to dual banana (m)	Agilent 1251-2277	P
Shorting cap	BNC	Agilent 1250-0774	P
Resistor (2)	5 Ω, 5 W	Agilent 0812-0047	T
Video monitor	Accepts VGA-standard video signals		T
Keyboard	PC-compatible, AT 5-pin connector	Agilent E2610A	T
Mouse	PS/2 compatible	Agilent C3751-60201	P, T
POST Card	Power-on self test card compatible with PC-compatible systems		T
Fan Safety Shield	Clips onto side of chassis with cover removed	Agilent 54801-00601	A, T
Service software	No substitution	Agilent 54810-68700	T

Note: the Fan Safety Shield and Service software are part of the Service Kit, Agilent P/N 54810-68703.

\* P = Performance Tests, A = Adjustments, T = Troubleshooting



- Setting Up the Oscilloscope 2-3
  - To inspect the instrument 2-3
  - To connect power 2-4
  - To connect the mouse or other pointing device 2-5
  - To attach the optional trackball 2-5
  - To connect the keyboard 2-7
  - To connect to the LAN card 2-7
  - To connect oscilloscope probes 2-8
  - To connect a printer 2-9
  - To connect an external monitor 2-10
  - To connect the GPIB cable 2-10
  - To tilt the oscilloscope upward for easier viewing 2-11
  - To power on the oscilloscope 2-12
  - To verify basic oscilloscope operation 2-13
  - To clean the instrument 2-14
  - To clean the display monitor contrast filter 2-14

---

# Preparing for Use

This chapter shows you how to prepare the Agilent Technologies 54810A/15A/20A/25A oscilloscopes for use. The following areas are covered in this section.

- Inspection
- Setup
- Connecting a signal
- Cleaning

Following instrument setup is a brief section covering oscilloscope operation. If you are unfamiliar with this oscilloscope's operation, refer to the *User's Quick Start Guide*. The topics covered include:

- Using the front panel
- Using the graphical interface
- Starting and stopping acquisition
- Adjusting oscilloscope configuration
- Making measurements

The Infiniium Oscilloscope is designed to make it easy for you to use a high-performance digitizing oscilloscope.

- The familiar front-panel oscilloscope interface with knobs and buttons is optimized for the most common kinds of troubleshooting tasks and basic measurements.
- The graphical interface with menus, windows, dialogs, and toolbars provides easy logical access to dozens of configuration and analysis tools, making it easy for you to set up and make the most complex measurements.

---

## Setting Up the Oscilloscope

This section will help you get the instrument ready to use. Included are procedures for:

- Inspection
- Connecting power
- Connecting probes and accessories
- Connecting peripherals
- Verifying basic operation
- Cleaning

---

## To inspect the instrument

- ❑ Inspect the shipping container for damage.

Keep a damaged shipping container or cushioning material until the contents of the shipment have been checked for completeness and the instrument has been checked mechanically and electrically.

- ❑ Check the accessories.

Accessories supplied are listed in chapter 1 of this service guide.

- If the contents are incomplete or damaged notify your Agilent Technologies Sales Office.

- ❑ Inspect the instrument.

- If there is mechanical damage or defect, or if the instrument does not operate properly or pass performance tests, notify your Agilent Technologies Sales Office.
- If the shipping container is damaged, or the cushioning materials show signs of stress, notify the carrier as well as your Agilent Technologies Sales Office. Keep the shipping materials for the carrier's inspection. The Agilent Technologies office will arrange for repair or replacement at Agilent Technologies' option without waiting for claim settlement.

## To connect power

The instrument Power Factor Correction (PFC) circuitry in the oscilloscope's power supply operates over a line voltage in the range of 100 to 240 Vac  $\pm 10\%$  (the power supply is autoranging to the input voltage and frequency). Line frequency must be in the range 47 to 440 Hz. Power consumption is 390W maximum.

- 1 Position the instrument where it will have sufficient clearance for airflow around the top, back, and sides.

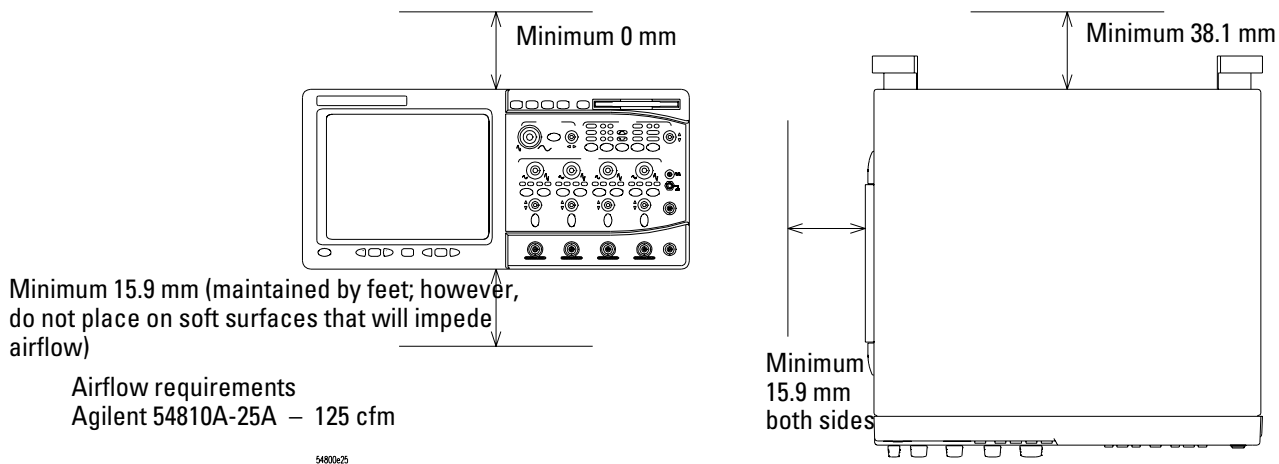

- 2 Connect the power cord to the rear of the oscilloscope, then to a suitable ac voltage source.

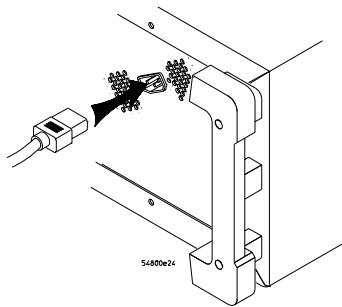

The line cord provided is matched by Agilent Technologies to the country of origin of order. Ensure that you have the correct line cord. See “Power Cables and Plug Configurations” in Chapter 7.

### WARNING

#### SHOCK HAZARD!

BEFORE YOU CONNECT THIS INSTRUMENT TO MAINS POWER OR LIVE MEASURING CIRCUITS, you must provide a protective earth ground. Failure to provide a protective earth ground could result in a shock hazard if there is a failure in this instrument or equipment connected to it.

The mains plug must be inserted in a socket outlet provided with a protective earth contact. Do not use an extension cord (power cable) without a protective conductor (grounding). Grounding one conductor of a two-conductor outlet does not provide an instrument ground.

#### A Three-wire Power Cable is Provided

This instrument is provided with a three-wire power cable. When connected to an appropriate ac power outlet, this cable grounds the instrument cabinet.

---

## To connect the mouse or other pointing device

- Plug the mouse into the matching connector on the back panel of the oscilloscope.

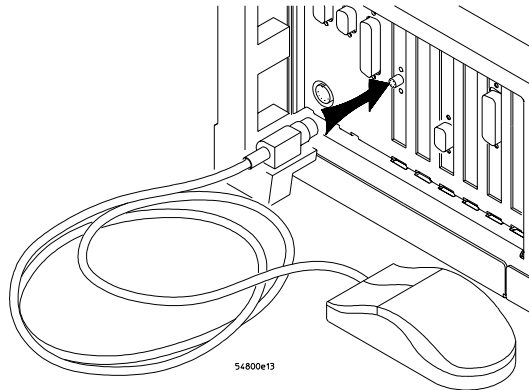

The mouse is included with the oscilloscope, but using it is optional. While you can operate many oscilloscope functions with only the front-panel keys and knobs, you will need the mouse to access advanced oscilloscope functions through the graphical interface, or to find out more about the oscilloscope through the built-in information system.

The optional touchpad pointing device connects in exactly the same way as the mouse.

The supplied mousepad provides the correct surface for smooth mouse operation. To modify the mouse configuration, see the *User's Quick Start Guide*.

---

## To attach the optional trackball

- 1 Push in the latch on the trackball baseplate to extend the metal tabs. Insert the lower tab into the frontmost slot on the side of the oscilloscope. You can only install the trackball on the right side of the oscilloscope.

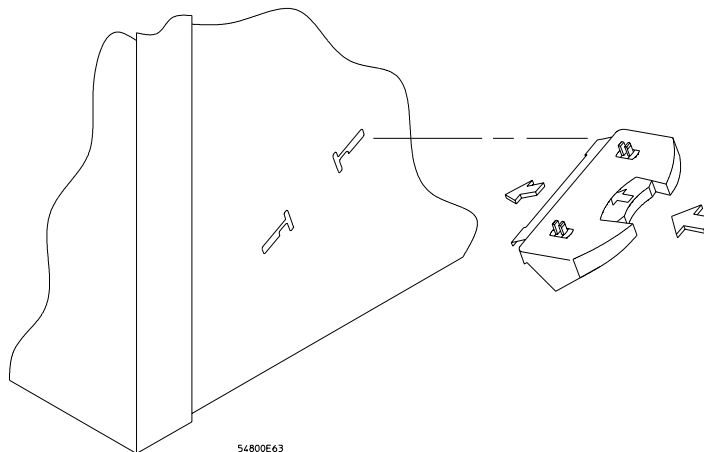

Chapter 2: Preparing for Use  
**To attach the optional trackball**

- 2** While holding the latch in, slide the metal tabs up and to the rear of the oscilloscope until they fully engage the slot.

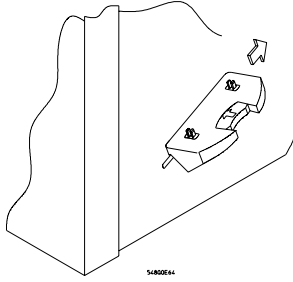

- 3** Release the latch. The trackball baseplate should now be secure against the side of the oscilloscope.

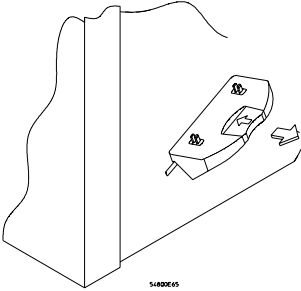

- 4** Snap the trackball assembly onto the pins of the baseplate. The trackball and buttons should face up and toward the front of the oscilloscope.

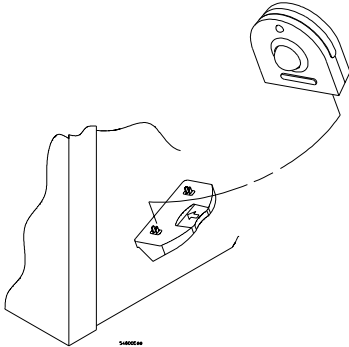

- 5** Connect the 9-pin “D” connector on the trackball cable to the COM1 port on the back panel. Tighten the retaining screws.

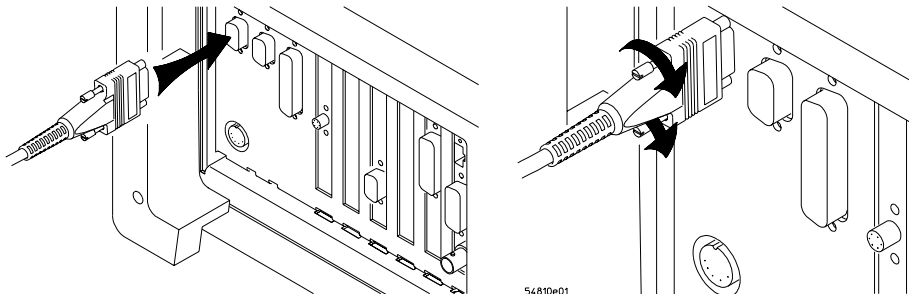

For information on changing the trackball settings, see the *User's Quick Start Guide*.

---

## To connect the keyboard

- Plug the keyboard cable into the matching connector on the back panel of the oscilloscope.

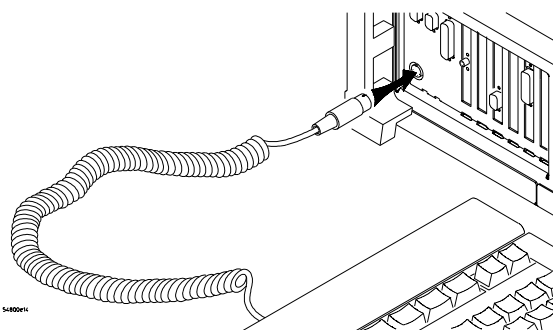

The keyboard simplifies access to some oscilloscope functions, such as entering file names when you store waveforms and setups to the disk. If you need to free desk space, place the keyboard on top of the instrument. Do not stack other objects on the keyboard; this will cause self-test failures on power-on.

---

## To connect to the LAN card

- Connect your LAN cable to one of the connectors on the LAN card. Make sure the connection is secure. Two connections are possible on the LAN card: the RJ-45 connection and a BNC connection. Units with 10/100Base-T LAN cards have an RJ-45 connector only.

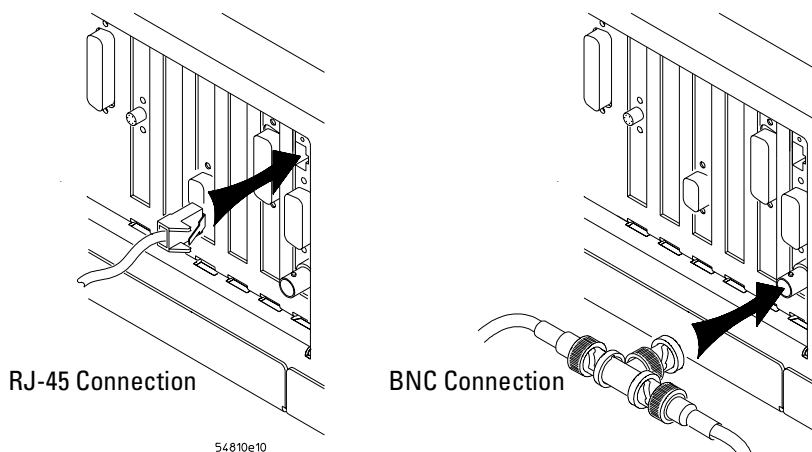

Each Infiniium Oscilloscope now ships with a LAN card installed. If you want a LAN connection, but have an older Infiniium Oscilloscope model that does not have a LAN card installed, contact your Agilent Technologies Sales and Service Office. An Agilent LAN Card Installation Kit with instructions is available from Agilent Technologies, and describes how to add a LAN card to your Infiniium Oscilloscope. After you have connected to the LAN card, you must set up the network as described in the *User's Quick Start Guide*.

---

## To connect oscilloscope probes

- 1 Attach the probe BNC connector to the desired oscilloscope channel or trigger input. Push it straight on until it latches into place.

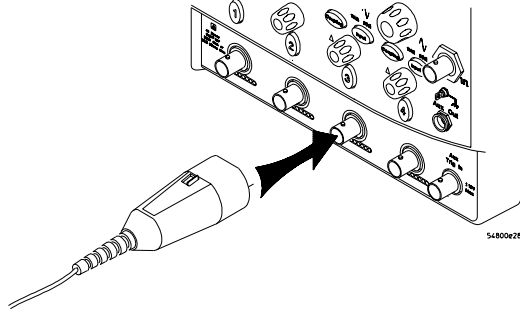

- 2 Connect the probe to the circuit of interest using grabbers or other probing aids.

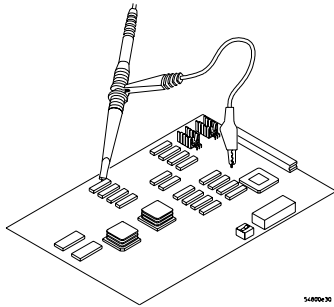

- 3 To disconnect the probe, push the small latch on top of the probe connector to the left, then pull the connector body away from the front panel of the oscilloscope without twisting it.

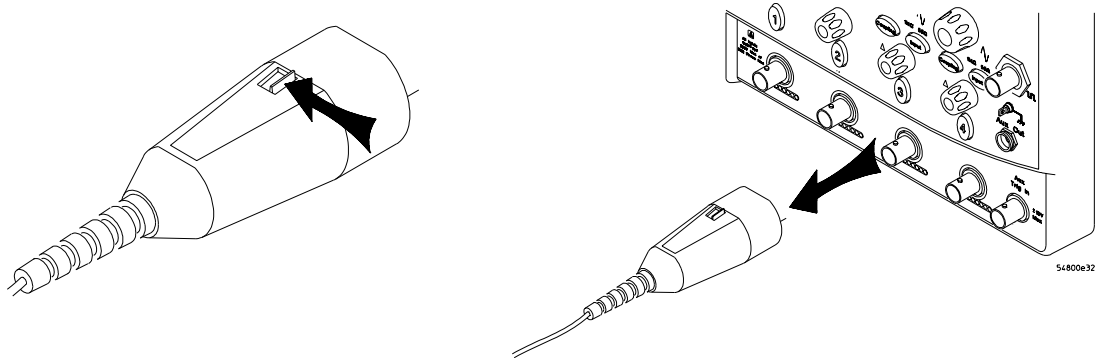

---

### CAUTION

**AVOID DAMAGE TO THE PROBE CONNECTOR!**

Do not attempt to twist the snap-on probes on or off the oscilloscope's BNC connector. Twisting the probe connector body will damage it.

---

### CAUTION



**DO NOT EXCEED THE MAXIMUM INPUT VOLTAGE!**

Do not exceed the maximum input voltage rating of the oscilloscope inputs! The maximum input voltage for 50- $\Omega$  inputs is 5 V<sub>rms</sub>, CAT I. The maximum input voltage for 1 M $\Omega$  inputs is  $\pm 250$ V (dc+ac) [ac < 10 kHz], CAT I. (Probes may have different ratings. See the probe documentation.)



---

## To connect a printer

If you have a parallel (Centronics) printer, you will need a parallel printer cable, such as an Agilent C2950A (2 m) or Agilent C2951A (3 m) cable. Go to step 1.

If you have a serial printer, you will need a 9-pin to 25-pin serial printer cable, such as an Agilent 34398A cable plus the Agilent 34399A adapter kit. Some printers may require other cable configurations, but the oscilloscope has a 9-pin serial connector. Go to step 4.

- 1 Attach the 25-pin small “D” connector to the printer output connector on the rear of the oscilloscope. Tighten the thumbscrews to secure the cable.

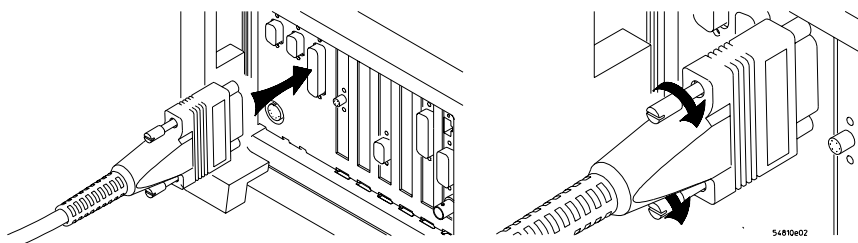

- 2 Attach the larger 36-pin “D” connector to the printer. Latch the wire bails into the tabs on each side of the connector.

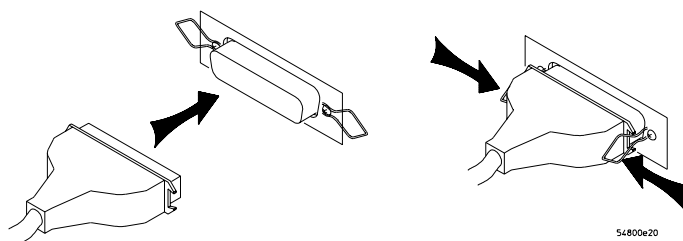

- 3 Set the printer configuration to use the “Centronics” or “Parallel” interface, if necessary. Refer to the *User’s Quick Start Guide* for software installation instructions. See the documentation for your printer if you have questions about configuring the printer to use the parallel interface.
- 4 Connect the 9-pin “D” connector of the serial printer cable to the serial output port on the rear panel of the oscilloscope. Tighten the thumbscrews to secure the cable.

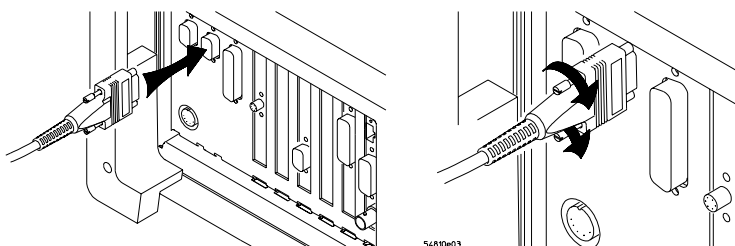

Chapter 2: Preparing for Use  
**To connect an external monitor**

- 5 Attach the 25-pin “D” connector to the serial input port of the printer. Tighten the thumbscrews to secure the cable.

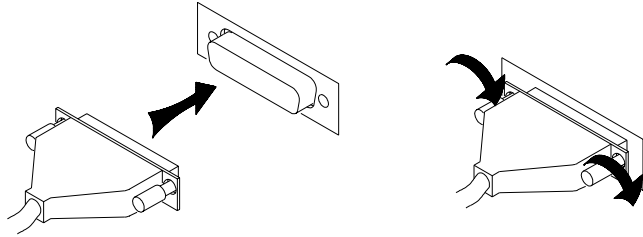

54800e23

- 6 Set the printer configuration to use the serial interface. Refer to the *User's Quick Start Guide* for software installation instructions.

See the documentation for your printer if you have questions about configuring the printer to use the serial interface.

---

## To connect an external monitor

You can connect a VGA-compatible monitor to the Infinium oscilloscope to provide a larger viewing area.

- Connect the monitor cable to the display board video connector at the rear panel of the oscilloscope. Tighten the retaining screws.

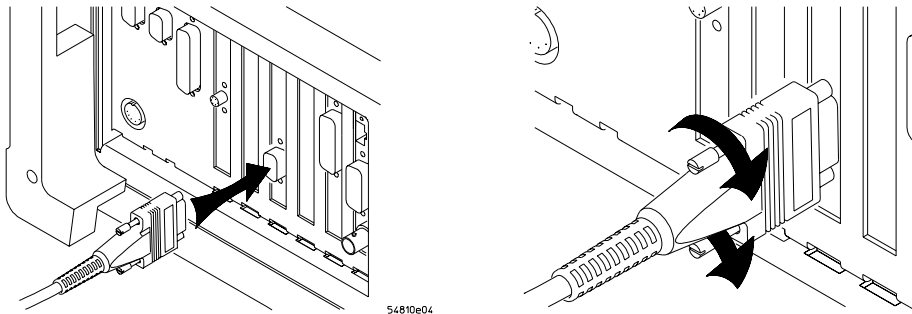

54810e04

---

## To connect the GPIB cable

- Attach the GPIB connector to the GPIB interface card connector at the rear of the oscilloscope. Tighten the thumbscrews on the connector.

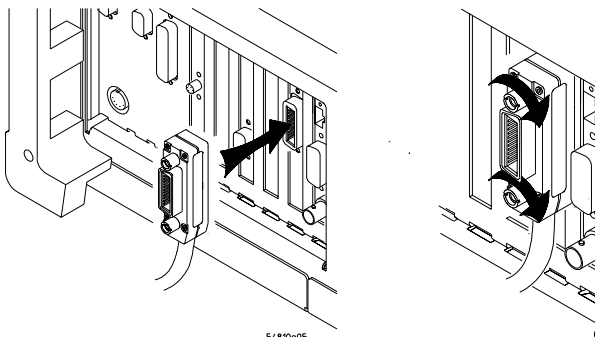

54810e05

---

## To tilt the oscilloscope upward for easier viewing

- If your oscilloscope has front feet with individual wire bails, lift up the front of the oscilloscope, grasp one of the wire bails under the front corner, and pull it down and forward until it latches into place. Repeat for the other wire bail.

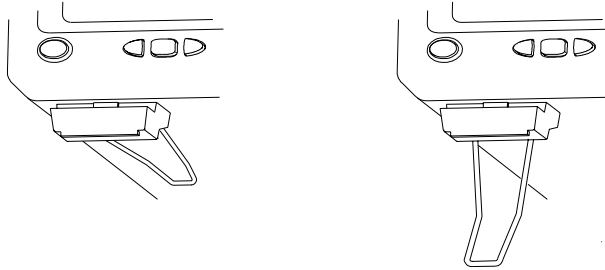

- If your oscilloscope has front feet with a wire bail between the two feet, lift up the front of the oscilloscope, grasp the bail near the center, and pull it down and forward until it latches into place.

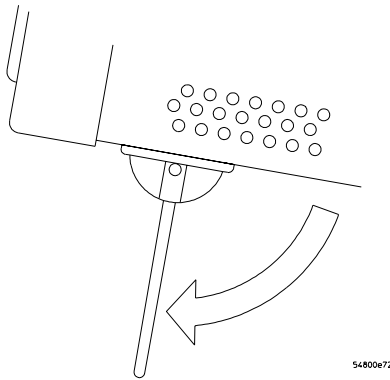

54800672

---

## To power on the oscilloscope

- Depress the power switch at the lower left-hand corner of the oscilloscope front panel.

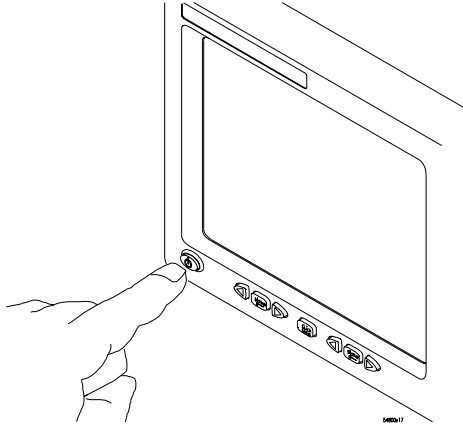

After a short initialization period, the oscilloscope display appears. The oscilloscope is ready to use.

Hook up all cables and accessories before applying power. You can connect and disconnect probes while the oscilloscope is powered-on.

### **You Can Configure the Backlight Saver**

The oscilloscope display has a backlight saver that turns off the backlight when there has been no interface activity for a pre-determined period. The default time is 8 hours and is configurable through the Display Setup dialog in the graphical interface. You can turn the display on by moving the mouse, typing on the optional keyboard, pressing a front-panel key, or turning a front-panel knob.

## To verify basic oscilloscope operation

- 1 Connect an oscilloscope probe to channel 1.
- 2 Attach the probe to the calibration output on the front panel of the oscilloscope.  
Use a probe grabber tip so you do not need to hold the probe. The calibration output is marked with a square wave symbol.

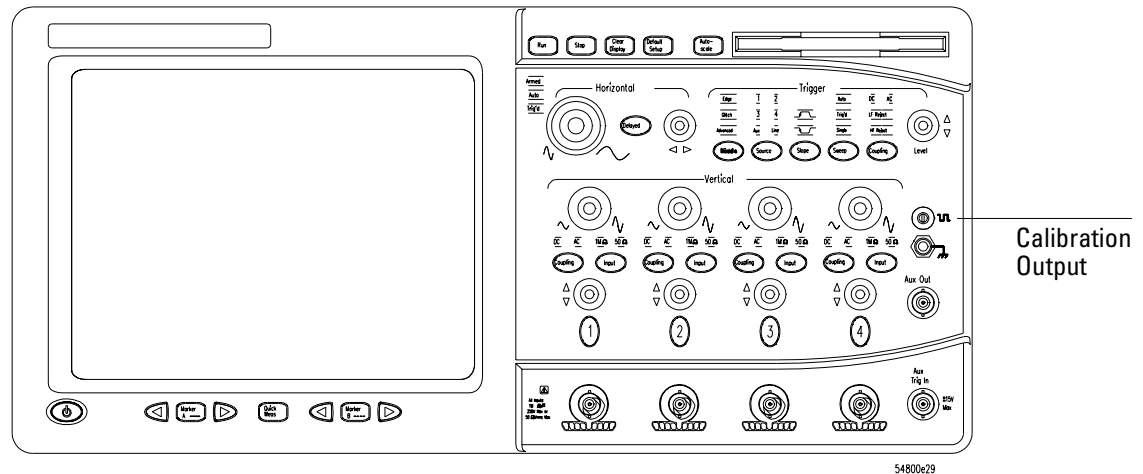

- 3 Press the Default Setup key on the front panel.  
The display will pause momentarily while the oscilloscope is configured to its default settings.
- 4 Press the Autoscale key on the front panel.  
The display will pause momentarily while the oscilloscope adjusts the sweep speed and vertical scale. You should then see a squarewave with peak-to-peak amplitude approximately 5 divisions and a period of almost 3 divisions. If you do not see the waveform, ensure your power source is adequate, the oscilloscope is properly powered-on, and the probe is connected securely to the front-panel channel input BNC and to the probe calibration output.
- 5 Move the mouse pointer to the graphical interface enable button and click once.  
The graphical interface enable button is in the upper-right corner of the display.
- 6 Move the mouse around the mouse pad and verify that the pointer follows on the screen.  
If the pointer does not move, ensure that the mouse is properly connected, that you have clicked the correct button to enable the graphical interface, and that the mouse is on a medium-friction surface such as the mouse pad supplied with the oscilloscope.

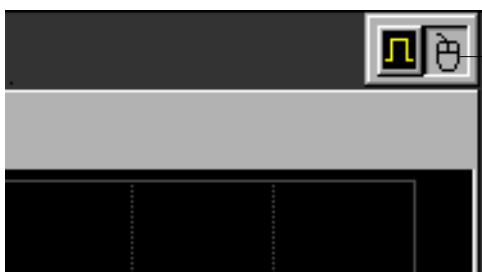

With the mouse pointer on the right-hand button, click the mouse to enable the graphical interface

Graphical Interface Enable Button

---

## To clean the instrument

- Clean the oscilloscope with a soft cloth dampened with a mild soap and water solution.

---

### **CAUTION**

BE CAREFUL TO AVOID DAMAGING COMPONENTS!  
Do not use too much liquid when cleaning the oscilloscope. Water can enter the front panel keyboard, damaging sensitive electronic components.

---

---

## To clean the display monitor contrast filter

- Clean the display monitor contrast filter using glass cleaner and lens tissue or a soft cloth.

Testing Interval 3-2  
Equipment Required 3-2  
Self-Test Verification 3-2  
Test Record 3-3  
Operating Hints 3-3  
Specifications 3-3  
Performance Test Procedures 3-3  
    To test the dc calibrator 3-4  
    To test input resistance 3-6  
    To test voltage measurement accuracy 3-7  
    To test offset accuracy 3-11  
    To test bandwidth 3-13  
    To test time measurement accuracy 3-15  
    To test trigger sensitivity 3-22  
Performance Test Record 3-27

---

# Testing Performance

The procedures in this section test the instrument's measurement performance using Performance Specifications given in chapter 1 as performance standards. Specifications applicable to individual tests are noted at the test for reference.

## Testing Interval

The performance test procedures may be performed for incoming inspection of the instrument and should be performed periodically thereafter to ensure and maintain peak performance. The recommended test interval is yearly or every 2,000 hours of operation.

### Testing Interval Dependencies

The test interval depends on frequency and severity of use and the environmental conditions under which the instrument is used. In recording test results, you may find that the test interval could be shortened or lengthened; however, such a decision should be based on substantial quantitative data.

### See Also

Chapter 4, "Calibrating and Adjusting," for information about the calibration cycle.

## Equipment Required

A complete list of equipment required for the performance tests is in the Recommended Test Equipment table in chapter 1. Equipment required for individual tests is listed in the test. Any equipment satisfying the critical specifications listed may be substituted for the recommended model. The procedures are based on the model or part number recommended.

## Self-Test Verification

To verify system operation with high confidence, without the test equipment and time required for performance tests, perform the self-tests. These internal tests verify many functions of the oscilloscope.

To run the self-tests, enable the graphical interface, then select Self Test from the Utilities menu. The Self Test drop down list box allows you to select Scope Self Tests, Key and Knob Test, or LED Test. A message is displayed with the instruction to remove all inputs to the instrument. During execution of the self-tests, the oscilloscope displays diagnostic messages indicating the status of each test.

If one of the self-tests fails, FAILED is displayed rather than PASSED, and a 16-bit diagnostic code is displayed. This code is used by factory service personnel when troubleshooting the main assembly. Failure of a self-test indicates either an assembly failure or the need to run the self-calibration. The assembly must be replaced before you attempt performance verification. For more troubleshooting information, refer to chapter 5, "Troubleshooting."



### **Test Record**

You can record the results of the performance tests in the Performance Test Record provided at the end of this chapter. The Performance Test Record lists the performance tests and provides an area to mark test results. You can use the results recorded at incoming inspection for later comparisons during periodic maintenance, troubleshooting, and after repairs or adjustments.

### **Operating Hints**

Some knowledge of operating the oscilloscope is helpful; however, these procedures are written so that little experience is necessary. The following two hints will speed progress of the testing.

#### **Clear Display**

When using many averages, it often takes awhile for a waveform display to stabilize after a change. When a control on the oscilloscope is changed, averaging automatically restarts. When just the input signal is changed, the instrument must average new data with the old so it takes longer for the waveform to stabilize.

Press the Clear Display key while changing input signals. The instrument will restart averaging and give a quick indication of the result of the signal change.

#### **Averaging**

Averaging is used to assure a stable signal for measurements. It is not necessary to wait for complete stability of the signal (averaging complete), as long as the measurement is well within the limits of the test.

### **Specifications**

The specifications that apply to a particular test are given with the test procedure. The specification as given with the test may be abbreviated for clarity. In case of any questions, refer to the complete specifications and characteristics in chapter 1, “General Information.”

### **Performance Test Procedures**

Performance test procedures start with the next paragraph. Procedures may be done individually and in any order.

#### **Let the Instrument Warm Up Before Using**

Allow the instrument to warm up for at least 30 minutes prior to beginning performance tests. Failure to allow warm-up may cause the instrument to fail tests.

---

## To test the dc calibrator

The Aux Out BNC on the front panel is used for self-calibration and probe calibration. Though calibrator accuracy is not specified in the performance specifications, it must be within limits in order to provide accurate self-calibration.

**Test Limits** -2.5 v to +2.5 v, Accuracy  $\pm 0.2\%$  of delta voltage output

---

### Equipment Required

Equipment	Critical Specifications	Recommended Model/Part
Digital Multimeter	0.1 mV resolution, better than 0.1 % accuracy	Agilent 34401A
Cable	BNC	Agilent 10503A
Adapter	BNC (f) to banana (m)	Agilent 1251-2277

### Procedure

- 1 Connect the multimeter to the front panel Aux Out BNC.  
Use the BNC cable and the BNC to banana plug adapter.
- 2 Enable the graphical interface.  
Use the mouse to click on the button in the upper right-hand corner of the display. See figure 3-1.

Figure 3-1



### Enabling the graphical interface

- 3 Press Default Setup to set the oscilloscope to default conditions.
- 4 Select Calibration from the Utilities menu.
- 5 Select DC from the Aux Output drop-down list box.  
See figure 3-2.

Figure 3-2

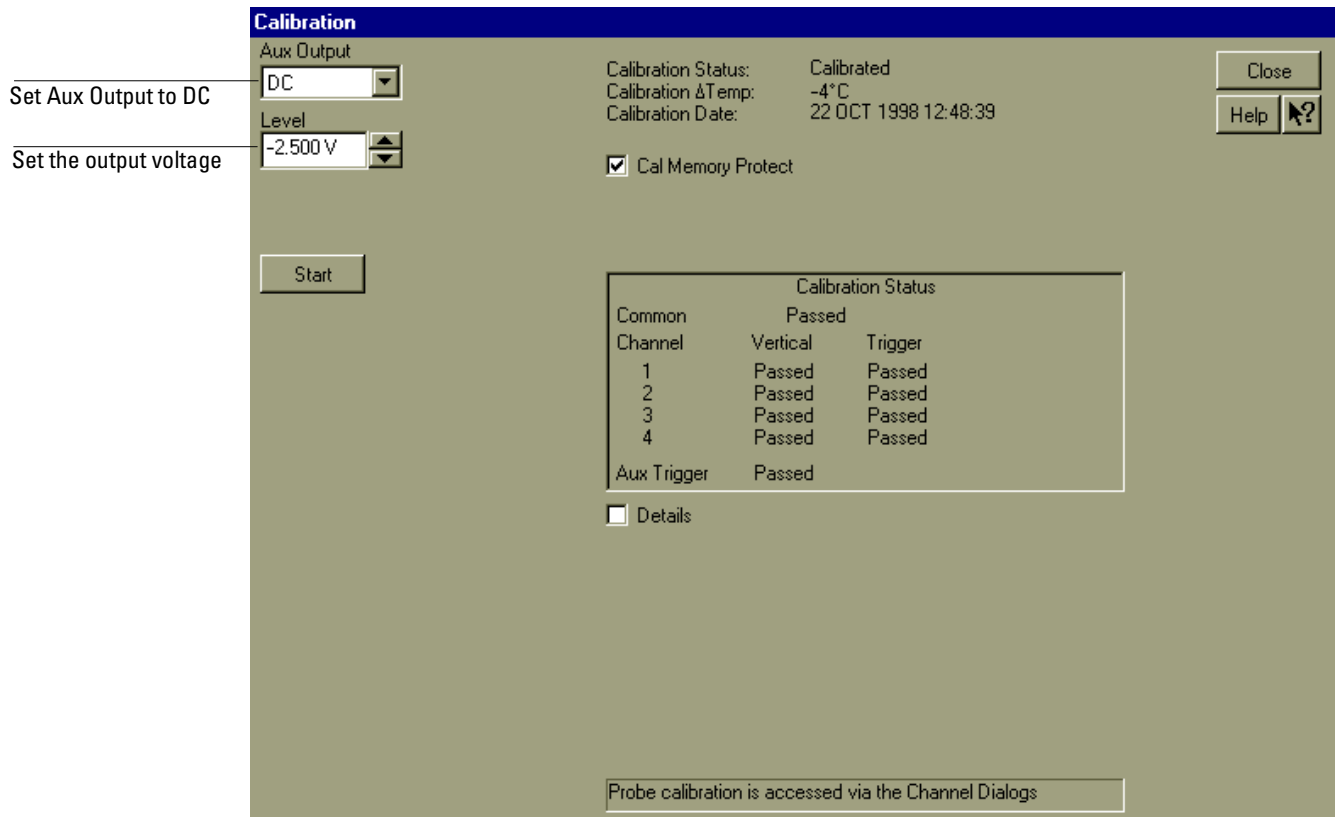

**Selecting DC in the Calibration Dialog**

- 6 Set the dc output voltage to +2.500 V using the Level spin box or the numeric keypad dialog.  
You can access the numeric keypad dialog by clicking on the value in the Level box. Enter the values by clicking on digits, signs, and exponents in the keypad. Click Close when finished.
- 7 The DVM should read near +2.500 V. Record the reading to four significant digits. V1 = \_\_\_\_\_.
- 8 Set the level to -2.500 V using the Level spin box or the numeric keypad dialog.
- 9 The DVM should read near -2.500 V. Record the reading. V2 = \_\_\_\_\_.
- 10 Subtract the second reading from the first reading, then divide the result by 5.  
For example, if the first reading is +2.498 V and the second reading is -2.497 V, then  

$$\frac{V1 - V2}{5} = \frac{2.489 - (-2.497)}{5} = 0.999$$
- 11 The final result should be between 0.998 and 1.002. Record the result in the Performance Test Record at the end of the chapter.
- 12 Click Close to exit the calibration screen.

**If the test fails**  
Repair is necessary. See chapter 5, "Troubleshooting."

---

## To test input resistance

This test checks the input resistance of the vertical inputs. A four-wire measurement is used to accurately measure the  $50\Omega$  and  $1\text{ M}\Omega$  inputs.

**Specification:**  $1\text{ M}\Omega \pm 1\%$  and  $50\ \Omega \pm 1\%$

---

### Equipment Required

Equipment	Critical Specifications	Recommended Model/Part
Digital Multimeter	Measure resistance (4-wire) at better than 0.25% accuracy	Agilent 34401A
Cables (2)	BNC	Agilent 10503A
Adapter	BNC Tee (m)(f)(f)	Agilent 1250-0781
Adapters (2)	BNC (f) to dual banana (m)	Agilent 1251-2277

### Procedure

- 1 Set up the multimeter to make a four-wire resistance measurement.
- 2 Assemble the test cables.
  - a Use the two BNC-to-banana adapters to connect one end of each BNC cable to the four-wire resistance connections on the multimeter.
  - b Connect the free ends of the cables to the BNC tee.

See the following figure.

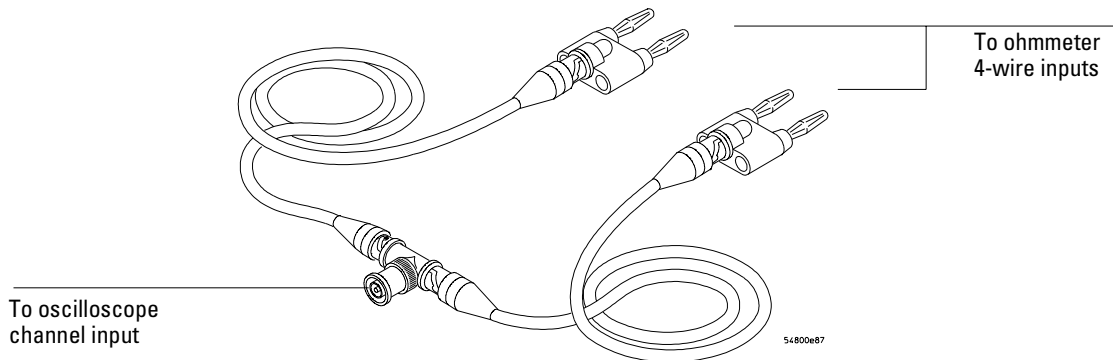

- 3 Connect the male end of the BNC tee to the channel 1 input of the oscilloscope.
- 4 Press Default Setup to set the oscilloscope to default conditions.
- 5 Press the Input key for Channel 1 to select  $1\text{ M}\Omega$ , then  $50\Omega$ , and verify resistance readings of  $1\text{ M}\Omega \pm 10\text{ k}\Omega$  and  $50\ \Omega \pm 0.5\ \Omega$  respectively.
- 6 Record the readings in the Performance Test Record.
- 7 Repeat steps 3 through 6 on the remaining channels and on the Ext trigger of the Agilent 54810A and 54820A.

---

## To test voltage measurement accuracy

This test verifies the voltage measurement accuracy of the instrument. The measurement is made using dual-cursor automatic measurement so that offset errors are not a factor.

A power supply provides a reference voltage to check voltage measurement accuracy. The actual supply voltage is monitored for accuracy using a NIST-traceable voltmeter (especially at low voltages). A dc blocking capacitor and a BNC short are used to filter any noise generated by the power supply so it does not appear at the oscilloscope input.

### Specification

Only the dual-cursor specification is tested.

**Single Cursor Measurement:**  $\pm(\text{gain accuracy} + \text{offset accuracy} + \text{resolution}/2)$

**Dual Cursor Measurement:**  $\pm(\text{gain accuracy} + \text{resolution})$

**Gain Accuracy:**  $\pm 1.25\%$  of full scale at full resolution channel scale

**Resolution:** 8 bits, (0.4% of full scale without averaging); or 12 bits, (0.024% of full scale with 32 averages) at full resolution scale

**Offset Accuracy:**  $\pm(1.25\%$  of channel offset + 2% of full scale) at full-resolution scale

---

### Equipment Required

Equipment	Critical Specifications	Recommended Model/Part
Power Supply	7 mV to 30 Vdc, 0.1 mV resolution	Agilent 6114A
Digital Multimeter (DVM)	Better than 0.1% accuracy	Agilent 34401A
Cables (2)	BNC	Agilent 10503A
Adapters (2)	BNC (f) to banana (m)	Agilent 1251-2277
Adapters (2)	BNC tee (m)(f)(f)	Agilent 1250-0781
Blocking capacitor	0.18 $\mu\text{F}$	Agilent 10240B
Shorting cap	BNC	Agilent 1250-0774

### Procedure

#### 1 Connect the equipment.

See figure 3-3.

- a Use a BNC-to-banana adapter to connect a BNC cable to the power supply.
- b Connect a BNC tee to the other end of the cable and connect the tee to channel 1 of the oscilloscope.
- c Connect another BNC cable to the tee at the oscilloscope and connect a BNC tee to the other end of the cable.
- d Connect the blocking capacitor to the BNC tee and connect the BNC short to the blocking capacitor.
- e Connect a BNC-to-banana adapter to the same BNC tee and connect the adapter to the DVM input.

**Figure 3-3**

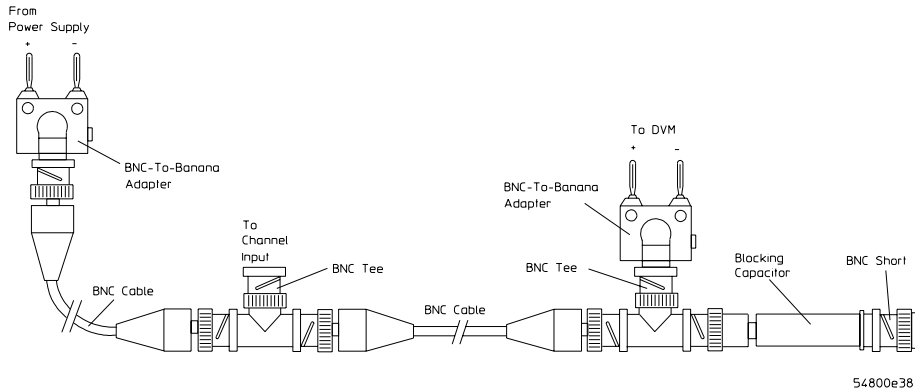

**Voltage Measurement Accuracy Equipment Setup**

- 2 Press Default Setup to set the oscilloscope to default conditions.
- 3 Set all channels to dc using the Coupling key and to 1 MΩ input impedance using the Input key.
- 4 Using the mouse, enable the graphical interface.
- 5 Select Acquisition from the Setup menu.
- 6 Select Equivalent Time sampling mode. Enable Averaging. Set the # Points to 32, either using the spin box or the numeric keypad dialog. Click Close.

See figure 3-4.

**Figure 3-4**

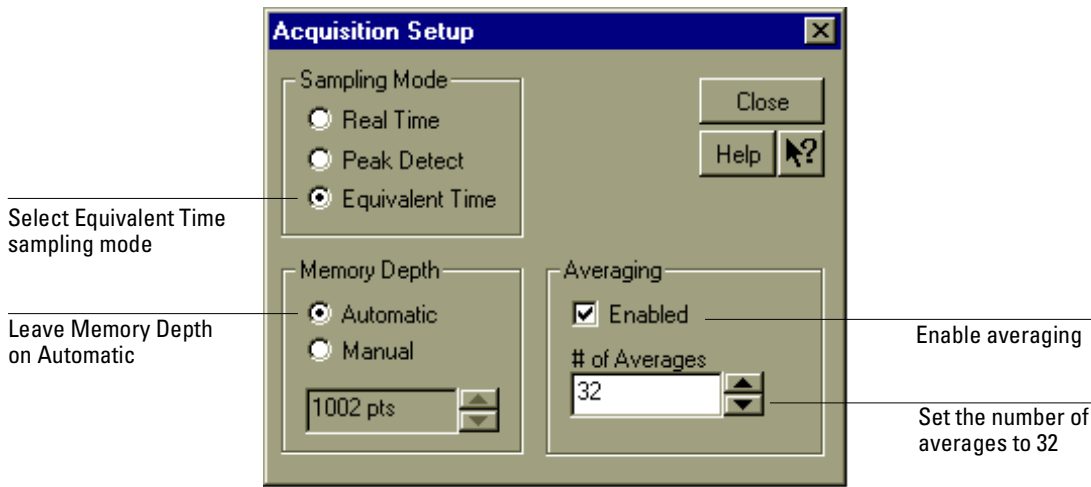

**Acquisition Setup for Voltage Accuracy Measurement**

- 7 Use the following table for steps 8 through 15.

Volts/div	Position	Supply	Tolerance	Limits	
				minimum	maximum
5 V	17.5 V	35 V	+/- 510 mV	34.490 V	35.510 V
2 V	7 V	14 V	+/- 204 mV	13.796 V	14.204 V
1.25 V	4.375 V	8.75 V	+/- 127 mV	8.623 V	8.877 V
500 mV	1750 mV	3.5 V	+/- 51 mV	3.449 V	3.551 V
250 mV	875 mV	1750 mV	+/- 25.48 mV	1724.52 mV	1775.48 mV
100 mV	350 mV	700 mV	+/- 10.19 mV	689.808 mV	710.19 mV
50 mV	175 mV	350 mV	+/- 5.096 mV	344.904 mV	355.096 mV
20 mV	70 mV	140 mV	+/- 2.038 mV	137.962 mV	142.038 mV
10 mV	35 mV	70 mV	+/- 1.019 mV	68.981 mV	71.019 mV
7 mV	24.5 mV	49 mV	+/- 0.713 mV	48.287 mV	49.713 mV

Below 7 mV/div expansion is used and full scale is defined as 56 mV. The ranges from 1 to 6 mV/div are handled in firmware, and will be within specifications when the 7 mV/div range is within specifications.

- 8 Select Vavg from the Voltage submenu of the Measure menu. Ensure that Channel 1 is selected in the Source dialog and click Close.

See figure 3-5.

**Figure 3-5**

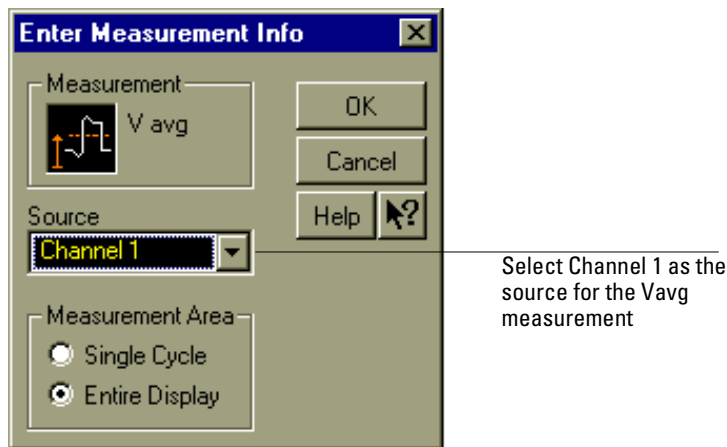

**Source Selection for Vavg Measurement**

- 9 Select Channel 1 from the Setup menu.
- 10 Set the vertical scaling for Channel 1 to the volts/div value from the first row of the table in step 7. Set the Offset value to the Position value from the first row of the same table. Click Close.

See figure 3-6.

Figure 3-6

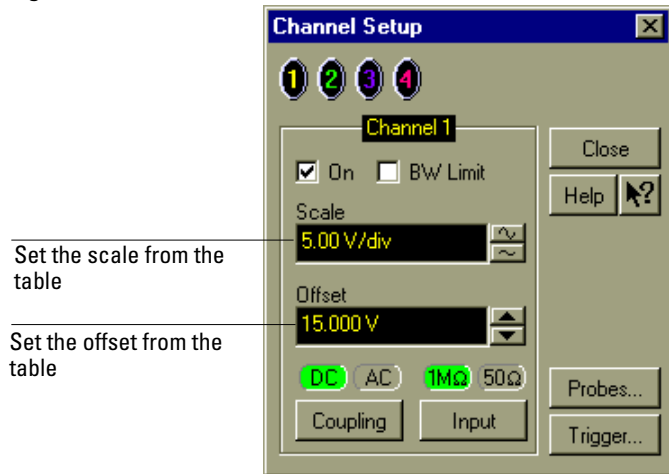

### Vertical Scaling and Offset for Voltage Accuracy Measurement

#### To Set Vertical Scale and Position

You can also use the knobs to set the vertical scale and position, but it is usually easier to use the dialog box, particularly for the fine position setting.

- 11 With the supply disconnected from the channel input, note the  $V_{avg}$  mean reading. \_\_\_\_\_ V  
It may take a moment for this value to settle because of averaging.
- 12 Set the power supply voltage from the first line of the table. Use the voltmeter to adjust the power supply for the most accurate output.
- 13 Connect the power supply to the channel input and note the  $V_{avg}$  reading. \_\_\_\_\_ V  
Press Clear Display and wait a moment to read the value (so that averaging is complete).
- 14 Subtract the value in step 11 from the value in step 13. Record the difference in the Performance Test Record.
- 15 On the same channel, repeat steps 10 through 14 for the rest of the rows in the table.
- 16 With the channel keys, set the active channel OFF and the next ON.  
A channel is ON if its key is illuminated and OFF if it is not illuminated.
- 17 Move the BNC tee to the next channel and repeat steps 8 through 15 for that channel.
- 18 Repeat steps 8 through 17 for the rest of the channels.

#### If the test fails

Voltage measurement errors can be caused by the need for self-calibration. Before troubleshooting the instrument, perform self-calibration. See "To run the self-calibration" in chapter 4, "Calibrating and Adjusting." If self-calibration fails to correct the problem, the cause may be the attenuator or main assembly.



## To test offset accuracy

This test checks the vertical offset accuracy.

**Specification:**  $\pm(1.25\%$  of channel offset +  $2\%$  of full scale) at full-resolution channel scale

### Equipment Required

Equipment	Critical Specifications	Recommended Model/Part
Power Supply	0.5 V to 2 Vdc, $\pm 1$ mV accuracy	Agilent 6114A
Digital Multimeter (DVM)	Better than 0.1% accuracy	Agilent 34401A
Cables (2)	BNC	Agilent 10503A
Adapters (2)	BNC (f) to banana (m)	Agilent 1251-2277
Adapters (2)	BNC tee (m)(f)(f)	Agilent 1250-0781
Blocking capacitor	0.18 $\mu$ F	Agilent 10240B
Shorting cap	BNC	Agilent 1250-0774

### Procedure

**1** Connect the equipment.

The cabling is the same as that used for the voltage measurement accuracy test. See figure 3-3.

- a** Use a BNC-to-banana adapter to connect a BNC cable to the power supply.
- b** Connect a BNC tee to the other end of the cable and connect the tee to channel 1 of the oscilloscope.
- c** Connect another BNC cable to the tee at the oscilloscope and connect a BNC tee to the other end of the cable.
- d** Connect the blocking capacitor to the BNC tee and connect the BNC short to the blocking capacitor.
- e** Connect a BNC-to-banana adapter to the same BNC tee and connect the adapter to the DVM input.

**2** Press Default Setup to set the oscilloscope to default conditions.

**3** Select Acquisition from the Setup menu.

**4** Select Equivalent Time under Sampling Mode. Enable Averaging, and set the # Points for averaging to 32. Click Close.

Setup is the same as that for the voltage measurement accuracy test. See figure 3-4.

**5** Use the following table for steps 6 through 12.

Volts/div	Position	Supply	Tolerance	Limits	
				minimum	maximum
200 mV	2.00000 V	2.00 V	$\pm 57$ mV	1.943	2.057 V
100 mV	1.00000 V	1.00 V	$\pm 28.5$ mV	0.9715	1.0285 V
50 mV	500.000 mV	500 mV	$\pm 14.25$ mV	485.75	514.25 mV

**6** Select Channel 1 from the Setup menu.

**7** Set the vertical Scale to the Volts/div value from the first row of the table. Set the Offset to the Position value from the first row of the table. Click Close.

**To test offset accuracy**

- 8 Set the supply voltage to 2.00 V as in the first row of the table. Use the DVM to verify the setting.
- 9 Re-adjust the vertical position, if necessary, so the trace is as close to the horizontal center line of the grid as possible after it has settled (averaging complete).
- 10 Read the position voltage. It should be equal to the DVM reading, within the limits given in the table. Record the reading in the Performance Test Record.  
To find the current position setting, select Channel 1 from the Setup menu and read the Offset field. Click Close when finished.
- 11 Repeat steps 6 through 10 for the other lines in the table.
- 12 With the channel keys, set the active channel OFF and the next ON.
- 13 Move the BNC from one channel to the next.
- 14 Repeat steps 6 through 13 for each channel, setting the parameters of the channel being tested where appropriate.

**If the test fails**

Offset errors can be caused by the need for self-calibration. Perform self-calibration (see chapter 4, "Calibrating and Adjusting") before troubleshooting the instrument.

## To test bandwidth

This test checks the bandwidth of the oscilloscope.

### Specification

**Equivalent Time (all models):** dc to  $\geq 500$  MHz

**Real Time:**

**Agilent 54810A and 54815A:** dc to  $\geq 250$  MHz

**Agilent 54820A and 54825A:** dc to  $\geq 500$  MHz

### Equipment Required

Equipment	Critical Specifications	Recommended Model/Part
Signal Generator	1—500 MHz at $\approx 200$ mVrms	Agilent 8656B
Power Meter/Sensor	1—500 MHz $\pm 3\%$ accuracy	Agilent 436A/8482A
Power Splitter	outputs differ by $< 0.15$ dB	Agilent 11667A
Cable	Type N (m) 24 inch	Agilent 11500B
Adapter	Type N (m) to BNC (m)	Agilent 1250-0082

### Equivalent Time Test

- 1 Connect the equipment.
  - a With the N cable, connect the signal generator to the power splitter input. Connect the power sensor to one output of the power splitter.
  - b With an N-to-BNC adapter, connect the other splitter output to the channel 1 input.
- 2 Press Default Setup to set the oscilloscope to default conditions.
- 3 Select Acquisition from the Setup menu. Select Equivalent Time sampling mode. Enable averaging and set the # Points to 32. Click Close.
- 4 Set the vertical scale for Channel 1 to 100 mV/div using the knob. Select 50 $\Omega$  input impedance.
- 5 Set the sweep speed to 50 ns/div using the horizontal sweep speed knob.
- 6 Set the signal generator for 10 MHz at +5.0 dBm.  
 The signal on the oscilloscope screen should be about five cycles at six divisions amplitude.

#### Bandwidth Check Limits

Do not exceed 6 divisions when making the bandwidth check.

- 7 Select  $V_{\text{amptd}}$  from the Voltage submenu of the Measure menu.
- 8 After the measurement settles (when averaging is complete, about 10 seconds), note the  $V_{\text{amptd}}(1)$  reading at the bottom of the screen.  $V_{10\text{MHz}} = \underline{\hspace{2cm}}$  mV.
- 9 Set the power meter Cal Factor % to the 10 MHz value from the calibration chart on the power sensor. Then press dB[REF] on the power meter to set a 0 dB reference. This establishes the baseline output power at 10 MHz as a reference for the bandwidth measurement.

**To test bandwidth**

- 10** Change the signal generator output frequency to 500 MHz and set the power meter Cal Factor % to the 500 MHz value from the calibration chart on the power sensor.

This step compensates the power meter reading for changes in the power sensor output at 500 MHz with respect to 10 MHz.

- 11** Adjust the signal generator output amplitude for a power reading as close as possible to 0.0 dB[REL]. Write down the actual reading. Reading = \_\_\_\_\_ dB [REL].

The reading on the power meter will be used to correct the final bandwidth value.

- 12** Set the sweep speed to 1 ns/div using the horizontal sweep speed knob.

- 13** After the measurement settles (averaging complete), note the  $V_{\text{amptd}(1)}$  reading.

$V_{500\text{MHz}} = \text{_____ mV}$ .

- 14** Calculate the response using the formula:

$$\text{response(dB)} = 20 \log_{10} \frac{V_{500\text{MHz}}}{V_{10\text{MHz}}} = 20 \log_{10} \text{_____} = \text{_____ dB}$$

For example:

$$20 \log_{10} \frac{487 \text{ mV}}{559 \text{ mV}} = 20 \log_{10} 0.871 = -1.19 \text{ dB}$$

- 15** Correct the result from step 14 with any difference in the power meter from step 11. Observe signs. For example:

Result from step 14 = -1.19 dB

Power meter reading = -0.5 dB(REL)

then true response = (-1.19) - (-0.5) = -0.69 dB

( \_\_\_\_\_ ) - ( \_\_\_\_\_ ) = \_\_\_\_\_ dB

- 16** The result from step 15 should be between +3.0 dB and -3.0 dB. Record the result in the Performance Test Record.

- 17** Switch the power splitter from the channel 1 to the channel 2 input.

- 18** Turn off the current channel and turn on the next channel using the channel keys.

- 19** Repeat steps 4 through 18 for the remaining channels, setting the parameters of the channel being tested where appropriate.

**Real Time Test**

- 20** Select Acquisition from the Setup menu.

- 21** Select Real Time sampling mode, turn off Averaging, then click Close.

- 22** Repeat steps 4 through 19, testing all vertical channels with the upper frequency limit as follows:

Agilent 54810A and 54815A; 250 MHz

Agilent 54820A and 54825A; 500 MHz

**If the test fails**

Failure of the bandwidth test can be caused by a faulty attenuator or main assembly, or the need for high-frequency pulse response adjustment.

---

## To test time measurement accuracy

This test uses a precise frequency source to check the accuracy of time measurement functions.

### Specification Delta-t accuracy

**Equivalent Time:** ( $\geq 16$  averages)

$$\pm[(0.005\% \times \text{delta-t}) + (\text{full scale}/(2 \times \text{memory depth})) + 60 \text{ ps}]$$

**Real Time:** \*  $\pm[(0.005\% \times \text{delta-t}) + (0.2 \times \text{sample period})]$

\* The specification applies to bandwidth limited signals ( $t_r \geq 1.4 \times \text{sample period}$ ).  
 The sample period is defined as  $1/(\text{sample rate})$ . The specification also applies to those automatic measurements computing time intervals on identical slope edges (like pos-pos, neg-neg).

---

### Equipment Required

Equipment	Critical Specifications	Recommended Model/Part
Signal Generator	1-40 MHz, timebase accuracy - 0.25 ppm	Agilent 8656B Opt. 001
RF Amplifier	40 MHz to 1 GHz, 20 dB gain	Agilent 8447D
Cable	Type-N 24 inch	Agilent 11500B
Cable	BNC	Agilent 10503A
Adapter	Type N (f) to BNC (m)	Agilent 1250-0077

The Agilent 8447D RF Amplifier is used as a saturation amplifier to create a very low-jitter squarewave from the sinewave output of the signal generator. You adjust the signal generator output level to change the risetime of the squarewave.

### Equivalent Time Mode Procedure

This test checks time measurement in equivalent time mode with averaging.

- 1 Set the Agilent 8656B signal generator for a 40-MHz sine wave (25.0 ns period) at  $250 \text{ mV}_{\text{rms}}$ .
- 2 Connect the output of the signal generator to the INPUT of the Agilent 8447D RF amplifier.
- 3 Connect the OUTPUT of the RF amplifier to the channel 1 input of the oscilloscope.
- 4 Press Default Setup to set the oscilloscope to default conditions.
- 5 Press Input to select  $50 \Omega$ . Press Coupling to select dc.
- 6 Press Autoscale.
- 7 Set the vertical scale to 500 mV per division.

- 8 Select horizontal from the setup menu. Set the scale to 5 ns/div, position at -5.0 ns, and reference to the left.

Figure 3-7



**Horizontal Setup for Equivalent Time Procedure**

- 9 Adjust the signal generator output voltage to obtain a waveform with a risetime of approximately 1.4-2.0 ns.  
You can measure the risetime by selecting the Risetime command from the Time submenu of the Measure menu. See figure 3-8.

Figure 3-8

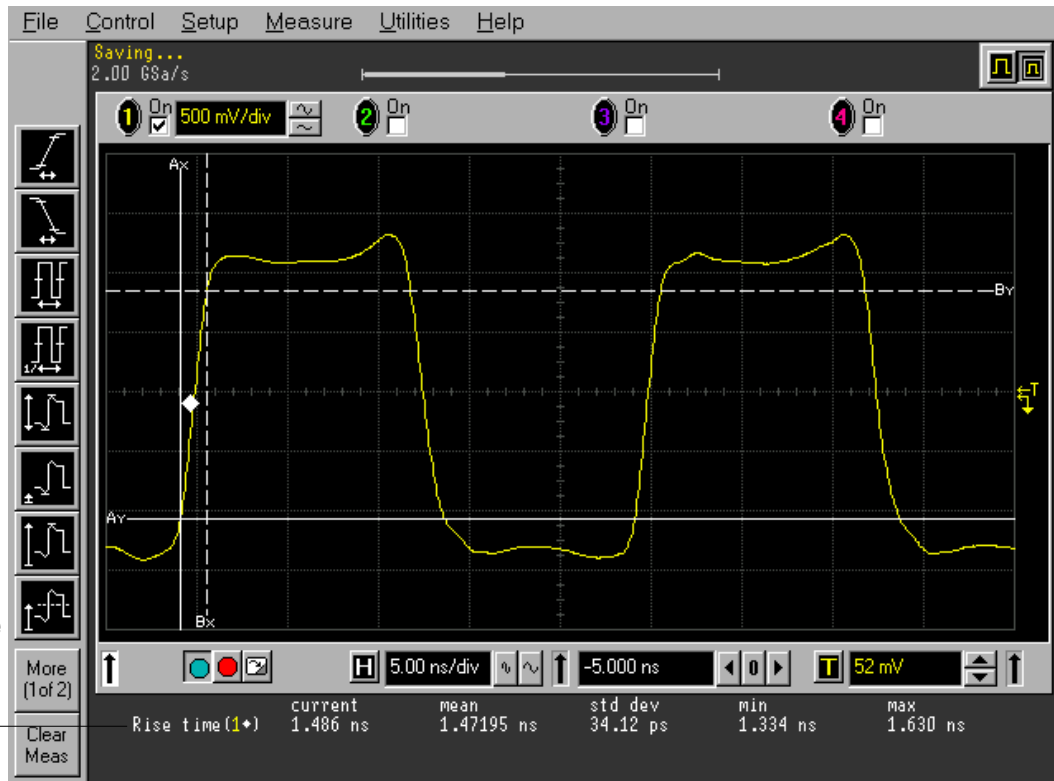

Use the risetime measurement to verify correct waveform shape for the time measurement accuracy check

**Waveform for Time Measurement Accuracy Check**

- 10 Select Acquisition from the Setup menu.

- 11 Select Equivalent Time sampling mode. Enable Averaging and set the # Points to be averaged to 16. Select Manual Memory Depth. Set the memory depth to 2004 points. Click Close.

See figure 3-9.

Figure 3-9

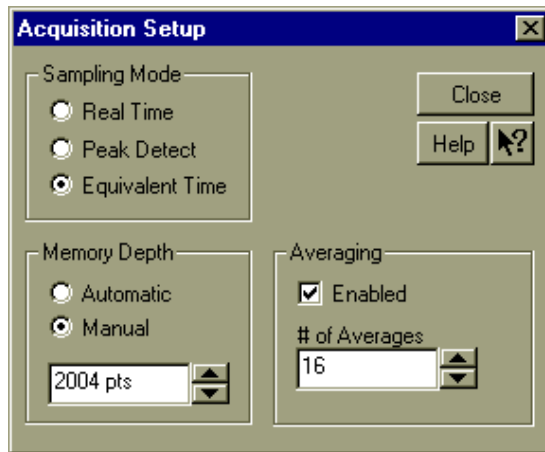

**Acquisition Setup for Equivalent Time Procedure**

- 12 Select Delta Time from the Time submenu of the Measure menu. Select Channel 1 as the source in the dialog that appears and click Close.

See figure 3-10.

Figure 3-10

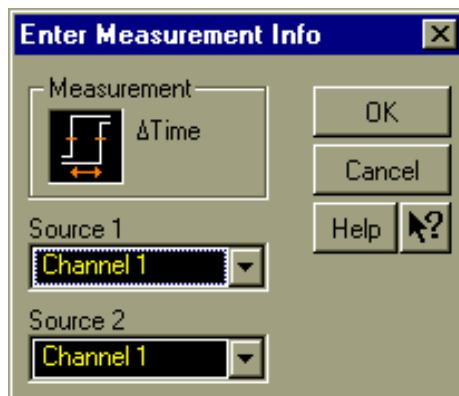

**Source Selection for Delta Time Measurement**

- 13 Select Measurement Definitions from the Customize submenu of the Measure menu. (If you have code Revision A.03.00 or higher, select Delta Time from the Measurements Definitions submenu of the Measure menu.)
- 14 Set From Edge # to 1 with Direction Rising and Threshold Middle. Set To Edge # to 2 with Direction Rising and Threshold Middle. Click Close.

See figure 3-11.

Figure 3-11

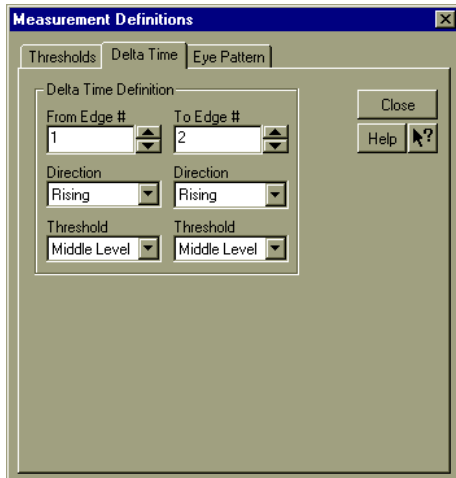

#### Measurement Settings for Time Interval Measurement

##### For Valid Statistical Data

In equivalent time mode, measurement specifications are valid with sixteen or more acquisitions averaged. Statistics accumulated before the required number of averaged acquisitions may show the instrument to fail the specification. This is particularly true for minimum and maximum in this case since they are set by measurements taken with the fewest averages.

If the procedure above is followed exactly, the required number of acquisitions are averaged before statistics are turned on. Therefore, if you clear and restart measurements, averaging and statistics are restarted simultaneously and the result is erroneous data collected from the early averages.

If in doubt about the statistical data, after #Avg is complete select Clear Measurements or Clear All from the Measure tool bar, then repeat the custom measurement again. This restarts the statistics without restarting averaging and the result is valid statistical data.

- 15 Verify the period is  $25 \text{ ns} \pm 74 \text{ ps}$ , minimum  $24.926 \text{ ns}$  and maximum  $25.074 \text{ ns}$ . Record the minimum and maximum readings in the Performance Test Record.
- 16 Change the signal generator frequency to  $100 \text{ MHz}$  ( $10 \text{ ns}$  period).
- 17 Select horizontal from the setup menu. Set the position to  $-11 \text{ ns}$ .
- 18 Clear measurement statistics.  
Do this by clicking Clear Meas (Clear All) on the measurement toolbar, then selecting Delta time from the Time submenu of the measure menu.
- 19 The delta time reading should be  $10 \text{ ns} \pm 73 \text{ ps}$ , minimum  $9.927 \text{ ns}$  and maximum  $10.073 \text{ ns}$ . Record the minimum and maximum readings in the Performance Test Record.
- 20 Change the signal generator frequency to  $20 \text{ MHz}$  ( $50 \text{ ns}$  period).
- 21 Select horizontal from the setup menu. Set the scale to  $100 \text{ ns/div}$ , position to  $-11 \text{ ns}$ .
- 22 Clear measurement statistics as in step 18, and restart the measurement.
- 23 The delta time reading should be  $50 \text{ ns} \pm 312 \text{ ps}$ ; minimum  $49.69 \text{ ns}$  and maximum  $50.31 \text{ ns}$ . Record the minimum and maximum readings in the Performance Test Record.
- 24 Change the signal generator frequency to  $1 \text{ MHz}$  ( $1 \mu\text{s}$  period).
- 25 Select horizontal from the setup menu. Set the scale to  $1 \mu\text{s/div}$ , position to  $-11 \text{ ns}$ .



- 26 Clear measurement statistics as in step 18, and restart the measurement.
- 27 The delta time reading should be  $1 \mu\text{s} \pm 2.6 \text{ ns}$ , minimum 997.4 ns and maximum 1.0026  $\mu\text{s}$ . Record the minimum and maximum readings in the Performance Test Record.
- 28 Select Measurement Definitions from the Customize submenu of the Measure menu. (If you have code Revision A.03.00 or higher, select Delta Time from the Measurements Definitions submenu of the Measure menu.)
- 29 Set the To Edge # to 6 with Direction Rising and Threshold Middle. Click Close. See figure 3-12.

Figure 3-12

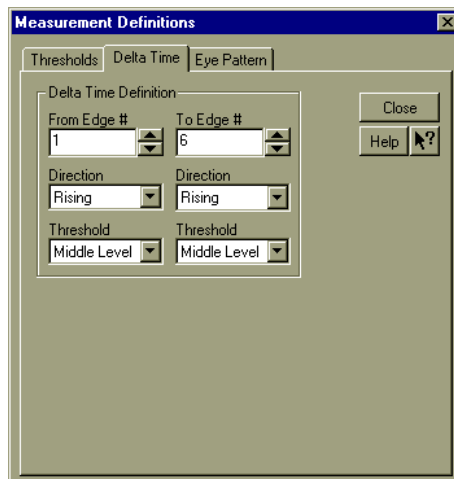

**New Measurement Settings for Delta Time Measurement**

- 30 Clear measurement statistics as in step 18 and restart the measurement.
- 31 The delta time readings should be  $5 \mu\text{s} \pm 2.805 \text{ ns}$ , minimum 4.9972  $\mu\text{s}$  and maximum 5.0028  $\mu\text{s}$ . Record the minimum and maximum readings in the Performance Test Record.

### Real-Time Mode Procedure

This procedure continues from the previous one.

- 1 Change the signal generator frequency to 25.31646 MHz (39.49999 ns period).
- 2 Select Acquisition from the Setup menu.
- 3 Select Real Time sampling mode. Set Sampling Rate to Manual, 1 GSa/s. Disable Averaging and set Memory Depth to Automatic. Click Close.

See figure 3-13.

Figure 3-13

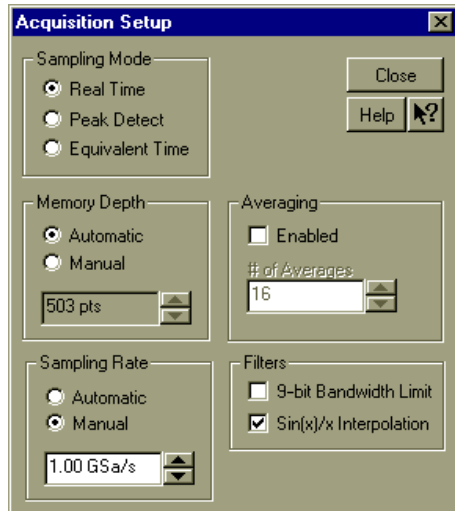

### Acquisition Setup for Real Mode Procedure

- 4 Set sweep speed to 50 ns/div with horizontal position at 0.0 s.
- 5 Select Measurement Definitions from the Customize submenu of the Measure menu. (If you have code Revision A.03.00 or higher, select Delta Time from the Measurements Definitions submenu of the Measure menu.)
- 6 Set To Edge # to 11 with Direction Rising and Threshold Middle. Click Close.

See figure 3-14.

Figure 3-14

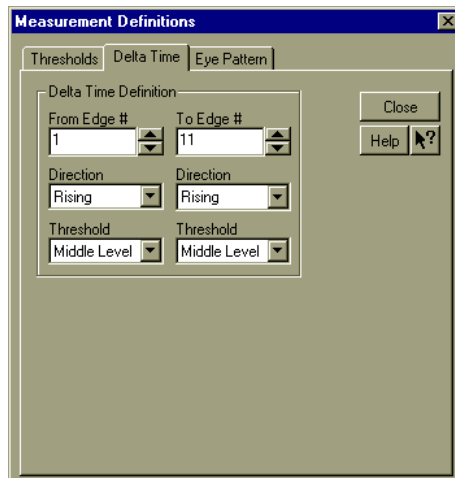

### Measurement Definitions for Real Mode Procedure

- 7 Clear measurements.
- 8 Select Period from the Time submenu of the Measure menu.
- 9 Period should be  $39.5 \text{ ns} \pm 201.97 \text{ ps}$ , minimum 39.298 ns, maximum 39.702 ns. Record the minimum and maximum readings in the Performance Test Record.
- 10 Select Delta Time from the Time submenu of the Measure menu.
- 11 Delta time should read  $395 \text{ ns} \pm 219.75 \text{ ps}$ , minimum 394.780 ns, maximum 395.220 ns. Record the minimum and maximum readings in the Performance Test Record.
- 12 Press the Stop key on the front panel.
- 13 Press the Sweep key (in the Trigger section of the front panel) to highlight the LED labeled "Single."
- 14 Press the Clear Display key.
- 15 Set the timebase to  $1 \mu\text{s}/\text{div}$ .
- 16 Press the Run key once.
- 17 Select Measurement Definitions from the Customize submenu of the Measure menu. (If you have code Revision A.03.00 or higher, select Delta Time from the Measurements Definitions submenu of the Measure menu.)
- 18 Set the To Edge # to 101 with Direction Rising and Threshold Middle. Click Close.
- 19 Delta time mean should read  $3.94999 \mu\text{s} \pm 397 \text{ ps}$ , minimum  $3.94959 \mu\text{s}$ , maximum  $3.95039 \mu\text{s}$ . Record the reading in the Performance Test Record.
- 20 Select Measurement Definitions from the Customize submenu of the Measure menu. (If you have code Revision A.03.00 or higher, select Delta Time from the Measurements Definitions submenu of the Measure menu.)
- 21 Set the To Edge # to 201.
- 22 The Delta time mean should read  $7.89998 \mu\text{s} \pm 595 \text{ ps}$ , minimum  $7.89938 \mu\text{s}$  and maximum  $7.90057 \mu\text{s}$ . Record the reading in the Performance Test Record.

**If the test fails**

Before troubleshooting the oscilloscope, be sure to verify your test setup and the waveform shape, then repeat the procedure. Try the measurement on different channels. If you still encounter problems, there may be a problem with the acquisition board. You may need to adjust the pulse overshoot response. See chapter 4 for adjustment information on the pulse response. See chapter 5 for troubleshooting information.

- 23 Click Close.

## To test trigger sensitivity

This test checks channel and external triggers for sensitivity at rated bandwidth.

Specification	dc to 100 MHz	100 MHz to 500MHz
<b>Internal:</b>	0.5 div	1.0 div
<b>External (Agilent 54810/20A):</b>	0.0225 × signal range	0.045 × signal range
<b>Auxiliary:</b>	dc to 500 MHz, 300 mV <sub>p-p</sub>	

### Equipment Required

Equipment	Critical Specifications	Recommended Model/Part
Signal Generator	100 and 500 MHz, 30-80 mVrms output	Agilent 8656B
Power Splitter	outputs differ by <0.15 dB	Agilent 11667A
Termination	BNC feedthrough, 50 Ω	Agilent 10100C
Cable	Type N (m) 24 inch	Agilent 11500B
Cable	50 Ω BNC 36 inch	Agilent 10503A
Adapter	Type N (f) to BNC (m)	Agilent 1250-0077
Adapter	Type N (m) to BNC (m)	Agilent 1250-0082
Adapter	Type N (m) to BNC (f)	Agilent 1250-0780
Adapter	BNC tee (m)(f)(f)	Agilent 1250-0781

### Internal Trigger Test

Perform this test on all vertical channels.

- 1 Press Default Setup.
- 2 Select Acquisition from the Setup menu.
- 3 Select Equivalent time sampling mode. Enable Averaging and set the number of points to 16. Click Close.

See figure 3-15.

**Figure 3-15**

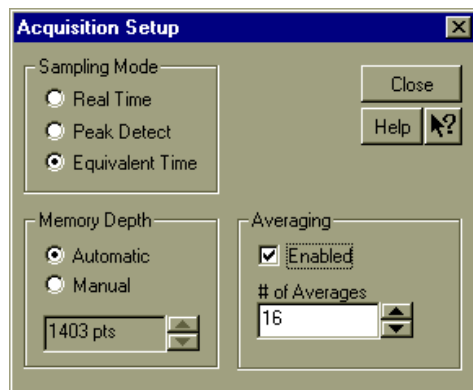

### Acquisition Setup for Trigger Sensitivity Test

- 4 Set horizontal time/div to 5 ns/div.

**5 Turn on Channel 1 and turn off all other channels.**

You can do this by using the channel keys above each input BNC or by using the check boxes at the top of the waveform display area.

**6 Set vertical scale for channel 1 to 200 mV/div. Select dc coupling and 50Ω input impedance.**

**7 With an N cable and N-to-BNC adapter, connect the signal generator to the channel 1 input.**

**8 Set the signal frequency to 100 MHz and output level for 0.5 divisions of vertical deflection.**

You can use the markers to set a 0.5 division reference. Select Markers from the Measure menu and select Manual Placement in the dialog that appears. Both Markers should be set to the same channel. Set the Y value for Marker A to +50.0 mV and the Y value for Marker B to -50.0 mV, then click Close. (If the markers do not appear on the screen, press the Marker A and Marker B keys on the front panel.) See figure 3-16.

**Figure 3-16**

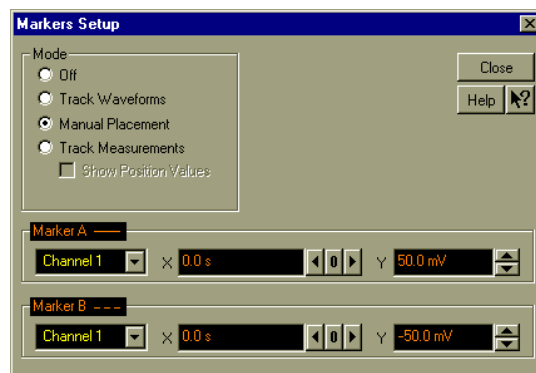

**Setting the Markers for a 0.5 Division Reference**

**9 Press the Sweep key (Trigger section of the front panel controls) to select Trig'd.**

The scope's Armed and Trig'd LEDs (in the Horizontal section of the front panel) should flash. However, the waveform display may not be stable.

**10 Adjust the trigger level control for a stable display.**

**11 The test passes if triggering is stable. Record the result in the Performance Test Record.**

**12 Set the signal frequency to 500 MHz and the output level for 1 division of vertical deflection.**

Again, you can use the markers to check the deflection, with one set to +100 mV and the other to -100 mV.

**13 Adjust the horizontal sweep speed to 1 ns/div.**

**14 Adjust the trigger level for a stable display.**

**15 The test passes if triggering is stable. Record the result in the Performance Test Record.**

**16 Connect the signal generator to the channel 2 input.**

**17 Repeat steps 4 through 16 for the remaining channels.**

**Procedure—External Trigger Test (2-channel models only)**

This test is necessary only on the Agilent 54810A and Agilent 54820A.

- 1** Connect the equipment.
  - a** With the N cable, connect the signal generator to the power splitter input.
  - b** Using an N-to-BNC adapter and BNC cable, connect one splitter output to the channel 1 input.
  - c** Press the channel 1 button to turn the channel on. Set the channel to  $50\Omega$ , DC coupling.
  - d** Connect the second splitter output to the Ext Trig input.
- 2** Set the signal generator frequency to 100 MHz and the output level to  $32\text{ mV}_{\text{rms}}$  ( $90\text{ mV}_{\text{pp}}$  from the generator,  $45\text{ mV}_{\text{pp}}$  into the trigger).
- 3** Press Autoscale.
- 4** Use the Ext Trig Input Range knob to set the range to  $\pm 1\text{ V}$ . Set Input to  $50\Omega$  and coupling to dc.
- 5** Press the Source key to select Ext.
- 6** Press the Sweep key to select Trig'd.
- 7** Adjust the trigger level for a stable display.
- 8** The test passes if triggering is stable. Record the result in the Performance Test Record.
- 9** Set the signal generator frequency to 500 MHz and output level to  $64\text{ mV}_{\text{rms}}$  ( $180\text{ mV}_{\text{pp}}$  from the generator,  $90\text{ mV}_{\text{pp}}$  into the trigger).
- 10** Adjust the trigger level for a stable display.
- 11** The test passes if triggering is stable. Record the result in the Performance Test Record.

**Procedure—Auxiliary Trigger Test (4-channel models only)**

This test is necessary only on the Agilent 54815A and Agilent 54825A.

The auxiliary trigger input is on the front panel of the oscilloscope near the vertical inputs. The dc input resistance of the aux trigger is 2.58k $\Omega$ , so to avoid reflections, the trigger source is back-terminated with 50  $\Omega$ .

- 1 With an N-to-BNC adapter and BNC cable, connect the signal generator to the input of the power splitter. Connect one output of the power splitter to the Aux Trig input through a 50  $\Omega$  feedthrough termination. Connect the other output of the power splitter to channel 1.
- 2 Set the signal generator for 500 MHz, approximately 0 dBm.
- 3 Set the channel 1 input to 50- $\Omega$  input impedance and press Autoscale.
- 4 Set the channel 1 scaling to 50 mV/div. Then set the signal generator for 6 divisions of signal (300 mV<sub>pp</sub>).
- 5 Press the Source key (Trigger section of front panel) to highlight Aux.
- 6 Set the trigger level to 0.000 V.
- 7 Slowly adjust the Trigger Level knob slightly around the 0 V setting to obtain a stable trigger. Otherwise, the test fails. Record the result in the Performance Test Record.

**If a test fails**

Failure of the internal trigger or external trigger sensitivity tests can be caused by a defective main assembly or attenuator. Failure of the auxiliary trigger sensitivity is caused by a problem on the main assembly or a bad input cable. If you need further troubleshooting information, go to chapter 5, "Troubleshooting."





# Agilent Technologies

**Agilent 54810A/54815A/54820A/54825A Oscilloscopes**

Model Number \_\_\_\_\_

Tested by \_\_\_\_\_

Serial Number \_\_\_\_\_

Work Order No. \_\_\_\_\_

Recommended Test Interval - 1 Year/2000 hours

Date \_\_\_\_\_

Recommended next testing \_\_\_\_\_

Ambient temperature \_\_\_\_\_

Test	Limits (Vmax - Vmin)/5 =Limits			Results			
<b>dc Calibrator Amplitude</b>	1.000	0.998 to 1.002					
<b>Input Resistance</b>	50 Ω	49.5 Ω to 50.5 Ω		<b>Channel 1</b>	<b>Channel 2</b>	<b>Channel 3</b>	<b>Chan 4/Ext</b>
	1 MΩ	990 kΩ to 1.010 MΩ					
<b>Voltage Measurement Accuracy</b>	<b>Range</b>	<b>Supply</b>	<b>Limits</b>				
	5 V/div	35 V	34.490 V to 35.510 V				
	2 V/div	14 V	13.796 V to 14.204 V				
	1.25 V/div	8.75 V	8.623 V to 8.887 V				
	500 mV	3.5 V	3.449 V to 3.551 V				
	250 mV	1750 mV	1724.52 mV to 1775.48 mV				
	100 mV	700 mV	689.808 mV to 710.19 mV				
	50 mV	350 mV	344.904 mV to 355.096 mV				
	20 mV	140 mV	137.962 mV to 142.038 mV				
10 mV	70 mV	68.981 mV to 71.019 mV					
7 mV	49 mV	48.287 mV to 49.713 mV					
<b>Offset Accuracy</b>	<b>Range</b>	<b>Offset</b>	<b>limits</b>				
	200 mV/div	2.0 V	1.943 to 2.057 V				
	100 mV/div	1.0 V	0.9715 to 1.0285 V				
50 mV/div	500	485.75 to 514.25 mV					
<b>Bandwidth</b>		<b>Down from reference:</b>		<b>Channel 1</b>	<b>Channel 2</b>	<b>Channel 3</b>	<b>Channel 4</b>
	<b>Equivalent Time</b>	<3.0 dB at 500 MHz					

Test	Limits		Results			
<b>Bandwidth (Cont'd)</b>	<b>Realtime</b>					
	Agilent 54810A/54815A	<3.0 dB at 250 MHz	_____	_____	_____	_____
	Agilent 54820A/54825A	<3.0 dB at 500 MHz	_____	_____	_____	_____
<b>Time measurement accuracy — equivalent time mode</b>	<b>ΔTime</b>	<b>Limits</b>	<b>Minimum</b>	<b>Maximum</b>		
	25 ns	24.926 to 25.074 ns	_____	_____		
	10 ns	9.927 to 10.073 ns	_____	_____		
	50 ns	49.69 to 50.31 ns	_____	_____		
	1 μs	997.4 to 1.0026 μs	_____	_____		
	5 μs	4.9972 to 5.0028 μs	_____	_____		
<b>Time measurement accuracy — real time mode</b>	<b>Period</b>	<b>Limits</b>				
	39.5 ns	39.298 to 39.702 ns	_____	_____		
	<b>ΔTime(edge#11)</b>	<b>Limits</b>				
	395 ns	394.780 to 395.220 ns	_____	_____		
	<b>ΔTime (edge#101)</b>	<b>Limits</b>				
	3.94999 μs	3.94959 to 3.95039 μs	_____	_____		
	<b>ΔTime (edge#201)</b>	<b>Limits</b>				
	7.89998 μs	7.89938 to 7.90057 μs	_____	_____		
<b>Trigger Sensitivity</b>	<b>Mode</b>	<b>Stable Trigger On:</b>	<b>Pass/Fail</b>			
	<b>Internal Trigger</b>	0.5 div at 100 MHz	<b>Channel 1</b>	<b>Channel 2</b>	<b>Channel 3</b>	<b>Channel 4</b>
		1.0 div at 500 MHz	_____	_____	_____	_____
	<b>External Trigger (Agilent 54810A and 54820A only)</b>					
on ±1 V range:	45 mV <sub>pp</sub> at 100 MHz	_____	_____			
	90 mV <sub>pp</sub> at 500 MHz	_____	_____			
<b>Auxiliary Trigger (Agilent 54815A and 54825A only)</b>						
	300 mV <sub>pp</sub> at 500 MHz	_____	_____			

Equipment Required	4-2
Self Calibration Interval and Hardware Adjustments	4-2
Mainframe Cal Factor Memory Error	4-2
Operating Hints	4-3
Loading Default Instrument Settings	4-3
Loading New Software	4-3
Calibration and Adjustment Procedures	4-3
To check the power supply	4-4
To check the 715 Hz auxiliary output (probe compensation square wave)	4-5
To check the flat panel display (FPD)	4-6
To adjust the high-frequency pulse response	4-9
To run the self-calibration	4-11

---

# Calibrating and Adjusting

This chapter provides firmware and hardware calibration and adjustment procedures for the Agilent Technologies 54810A/15A/20A/25A oscilloscopes.

- Power Supply Check
- Oscillator Check
- Flat-Panel Display Check
- Acquisition Assembly Calibration and Adjustment (Pulse Response)
- Self-Calibration

## Equipment Required

Equipment required for adjustments is listed in the Recommended Test Equipment table in chapter 1 of this manual. Any equipment that satisfies the critical specification listed in the table may be substituted for the recommended model. Equipment for individual procedures is listed at the procedure.

## Self Calibration Interval and Hardware Adjustments

The firmware calibration is the self cal (self calibration). Self calibration should be done every year, or every 2,000 hours of operation, whichever comes first. The hardware adjustment consists of checking the power supply, 715 Hz calibration output (probe compensation square wave), and flat-panel display. These adjustments only need to be done under circumstances set by certain needs, which are explained in other areas of this guide.

The self calibration uses signals generated in the oscilloscope to calibrate channel sensitivity, offsets, and trigger parameters. You should run the self calibration

- yearly, or according to your periodic needs,
- when you adjust or replace the acquisition assembly or acquisition hybrids,
- when you replace the hard drive or any other assembly,
- when the delta temperature is more than  $\pm 5$  °C different than the last calibration, or
- after performing incoming performance verification and before performing outgoing performance verification.

The need for self calibration will also depend on your experience and on the environment in which you use the oscilloscope.

## Mainframe Cal Factor Memory Error

If power is applied to the instrument and the message “Mainframe cal factor memory error: Please perform calibration” is displayed, you must calibrate the oscilloscope. See “To run the self-calibration” in this chapter.

If the instrument does not pass the self-calibration, repair is necessary.

### Operating Hints

Some knowledge of operating the Agilent Technologies 54810A/15A/20A/25A oscilloscopes is helpful. However, procedures are written so that little experience is necessary. The following hints will speed progress of the procedures.

When using many averages, it often takes awhile for a waveform display to stabilize after a change. When a front panel control on the oscilloscope is changed, averaging automatically restarts. When the input signal or an adjustment is changed, the instrument averages new data with the old, so it takes longer for the waveform to stabilize to the new value. Press the Clear Display key while changing input signals or adjustments. Clearing the display restarts averaging, which gives a quicker indication of the result of the change.

### Loading Default Instrument Settings

To reset the instrument to default conditions, press the Default Setup key.

### Loading New Software

This oscilloscope stores its operating system code on a hard disk drive. New code is loaded into the oscilloscope by using the floppy disk drive. It is rarely necessary to reload the code. You should load the code only if prompted by a troubleshooting procedure, or if you want to load a later version of code.

To load new code, enable the graphical interface, then select Upgrade Software from the Utilities menu. You can then follow the instructions on the screen, inserting diskettes as necessary.

### Calibration and Adjustment Procedures

The procedures start with the next paragraphs. Unless specified elsewhere, procedures must be followed in the order given. Display checks are optional and independent of other procedures.

#### Let the Instrument Warm Up Before Adjusting

Warm up the instrument for 30 minutes before starting adjustment procedures. Failure to allow warm-up may result in inaccurate calibration.

---

#### WARNING

#### SHOCK HAZARD!

Read the Safety information at the back of this guide before performing adjustment procedures. Failure to observe safety precautions may result in electrical shock.

---



---

#### WARNING

#### INJURY CAN RESULT!

Install the fan safety shield (included in the Service Kit) if you remove the oscilloscope cover. Without this shield, the oscilloscope fan blades are exposed and can cause injury.

---

## To check the power supply

There are no adjustments for the supply. Perform this procedure only if you suspect a power supply problem.

### Equipment Required

Equipment	Critical Specifications	Recommended Model/Part
Digital Voltmeter	Accuracy $\pm 0.05\%$	Agilent 34401A

### Procedure

- 1 Disconnect the instrument power cord and remove the cover.  
 If necessary, refer to the procedures in chapter 6, “Replacing Assemblies.”

### WARNING

**INJURY CAN RESULT!**

Use care when working around the instrument with the cover off and power applied. The fan blades are exposed and could cause injury; also, there is approximately 900 V generated by the backlight inverter for the flat-panel display.

- 2 Connect the oscilloscope power cord and set power switch to ON.
- 3 Refer to the following figure for test point locations. These are near the power supply connectors J10 and J11 on the acquisition assembly.

Figure 4-1

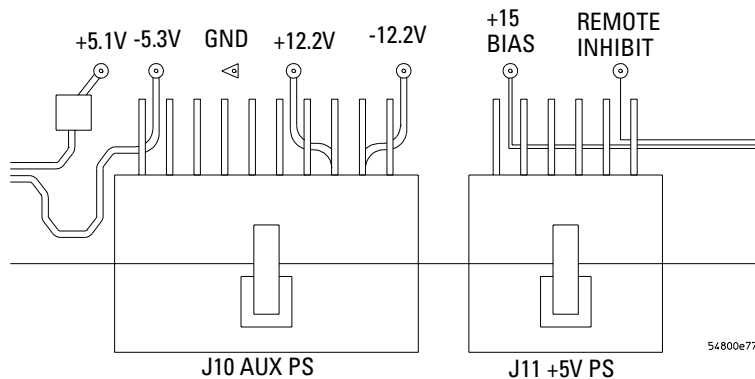

### Power Supply Test Points

- 4 Connect the common lead of the voltmeter to the GND test point.
- 5 Connect the positive lead of the voltmeter to the +5.1 V test point.
- 6 Verify that the +5.1 supply voltage is within limits as shown in the following table:

Table 4-1

### Power Supply Voltage Limits

Supply Voltage Specification	Limits
+5.1 V $\pm 0.1$ V	+5.0 V to +5.2 V
-5.3 V $\pm 0.1$ V	-5.2 V to -5.4 V
+12.2 V $\pm 0.3$ V	+11.9 V to +12.5 V
-12.2 V $\pm 0.3$ V	-11.9 V to -12.5 V
+15 V bias	

- 7 Repeat steps 4 through 6 for each of the other supply voltages.  
 If any supply voltage is not within specifications, see chapter 5, “Troubleshooting.”

## To check the 715 Hz auxiliary output (probe compensation square wave)

This test is optional. The 715 Hz auxiliary output is not specified in the instrument performance specifications. The values given are typical. Results are not recorded in the Performance Test Record.

### Equipment Required

You can check the 715 Hz auxiliary output using the scope itself.

### Procedure

- 1 Press Default Setup.
- 2 Use a BNC cable to connect the front panel Aux Out to the Channel 1 input.
- 3 Set Coupling to DC and Input to  $50\Omega$  for Channel 1.
- 4 Press Autoscale.
- 5 Select Vamp<sub>td</sub> from the Voltage submenu of the Measure menu.
- 6 Select Frequency from the Time submenu of the Measure menu.
- 7 The signal should be a square wave at approximately 715 Hz with amplitude of approximately  $330\text{ mV}_{\text{p-p}}$ .

---

## To check the flat panel display (FPD)

No equipment is required for this procedure. Specifications for flat-panel displays used in the Infiniium oscilloscopes are shown in the following table.

---

### Flat-Panel Display Specifications

Defect Type		Limit
Polarizer	Scratch	Width $\leq 0.05$ mm Length $\leq 10$ mm
	Dent	$\phi \leq 0.4$ mm
Dot Defect (A dot is defined as 1, 2, or 3 stuck subpixels touching horizontally. Subpixels are horizontal red, green, blue triads, so these may show up as one of 8 colors or black.)	Bright dot	$N \leq 5$
	Dark dot	$N \leq 7$
	Total dot	$N \leq 12$
	Two adjacent dots	
	Bright dot	$\leq 2$ pairs
	Dark dot	$\leq 2$ pairs
	Three or more adjacent dots	Not allowed
Distance between defects	Bright dot	$\geq 10$ mm
	Dark dot	$\geq 10$ mm
Line Defect		Not allowed
Non-uniformity		Check other specifications
Luminance (The measurement is perpendicular to the screen surface in both axes.)	Minimum	$160 \text{ cd/m}^2$
	Typical	$200 \text{ cd/m}^2$

#### When to Use this Procedure

This procedure should not be performed as a part of routine maintenance. Perform the procedure only when there appears to be a problem with the display.

- 1 Enable the graphical interface.
- 2 Select Self Test from the Utilities menu.
- 3 Click the Service Extensions box in the Self Test dialog.
- 4 Select Screen from the Test drop-down list box.

See figure 4-2.



Figure 4-2

Click to start the test  
Select Screen to do the flat-panel display test

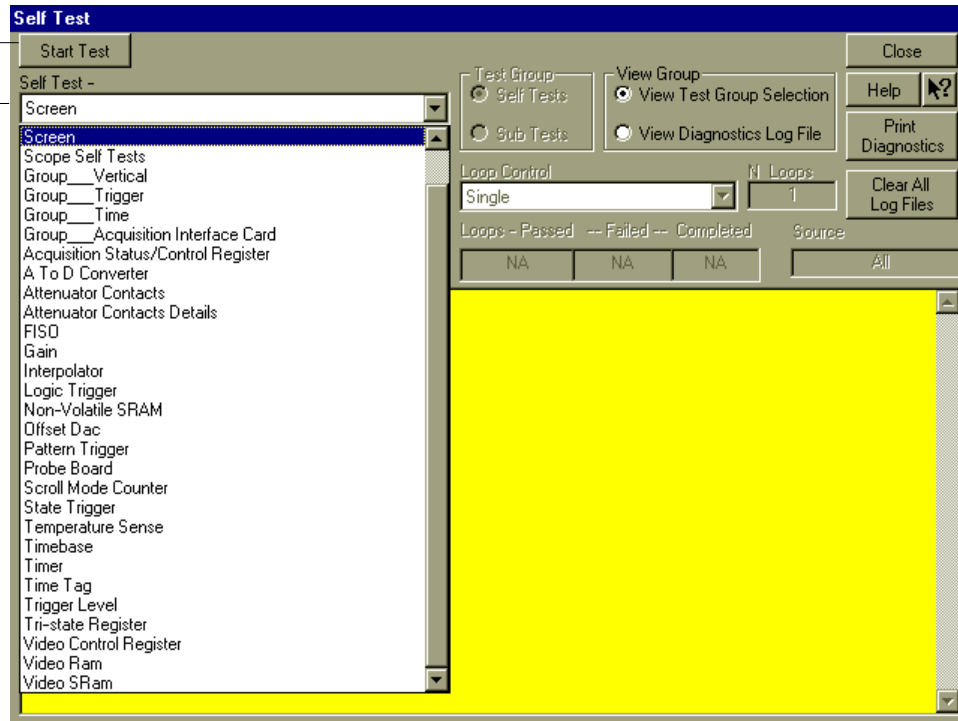

#### Starting the Screen Test

##### 5 Click Start.

A new dialog appears with a series of radio buttons that allow selection of different background colors. See figure 4-3.

Figure 4-3

Click one of these buttons to select the background color to check

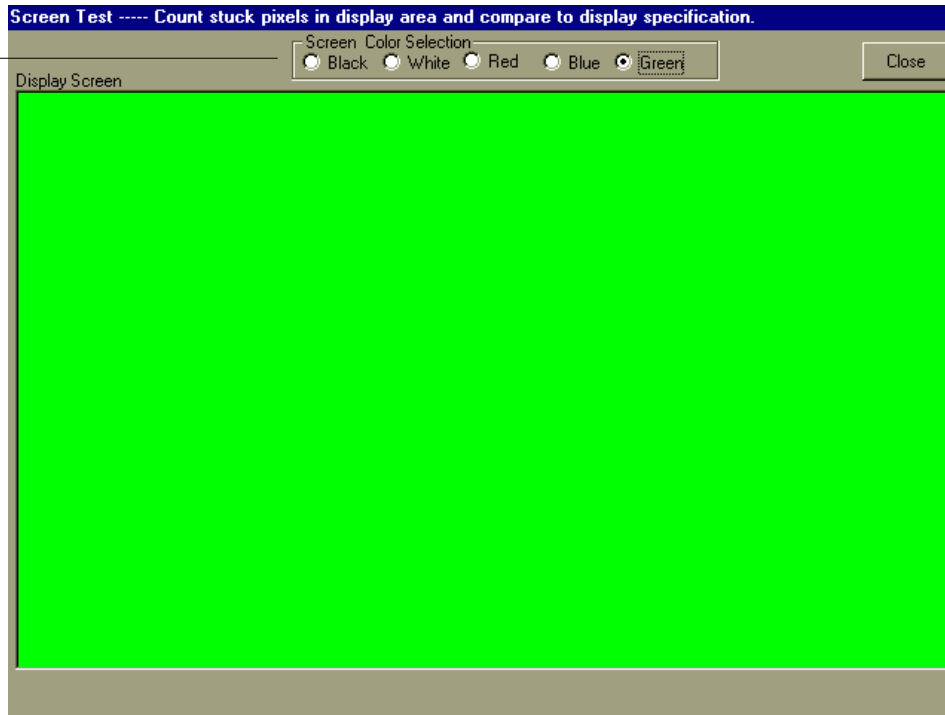

#### Screen Test

- 6 Select a color by clicking on the radio button for that color.
- 7 Carefully check the colored region for pixels colored differently than the current selection.

These pixels are either inactive or stuck. If black (when a color or white is selected), they are inactive; if another color than the current selection, but not black, then they are stuck. If the display does not meet the specification given on the previous page, replace it. See chapter 6 for removal and replacement procedures.

- 8 Repeat steps 6 and 7 for all colors.

## To adjust the high-frequency pulse response

This procedure optimizes the high-frequency pulse response, so the instrument will meet the bandwidth specification.

### When to use this procedure

*Do not perform this procedure as a part of routine maintenance.* Only perform this procedure when a channel fails the bandwidth performance test or when an attenuator, acquisition hybrid, or the acquisition assembly has been changed (new combination of attenuators, hybrids, and PC board). Only adjust the channels involved with the failure or repair. For example, if you replace an attenuator or hybrid, adjust only the channel where you replaced the component. If you replace the acquisition board, adjust all channels.

### Equipment Required

Equipment	Critical Specifications	Recommended Model/Part
Pulse Generator	$t_r < 175$ ps	Picosecond Pulse Labs 1110B Driver, 1107B Head
Adapter	SMA (f) to BNC (m)	Agilent 1250-1700

### Procedure

- 1 Disconnect the power cable, remove the cover, and install the fan safety shield.
- 2 Set the instrument on its right side so you will have access to the acquisition board at the bottom of the instrument.

### WARNING

#### INJURY CAN RESULT!

Use care when working around the instrument with the cover off and power applied. The fan blades are exposed and could cause injury; also, there is approximately 1.5 kV generated by the backlight inverter for the flat-panel display.

### CAUTION

#### ELECTROSTATIC DISCHARGE!

Use grounded wrist straps and mats when servicing the acquisition board. Electrostatic discharge can damage electronic components.

- 3 Connect the power cable and apply power.

You reach the adjustment for each channel through a hole in the heatsink over the acquisition hybrid for that channel. Use the following illustration to locate the adjustments.

Figure 4-4

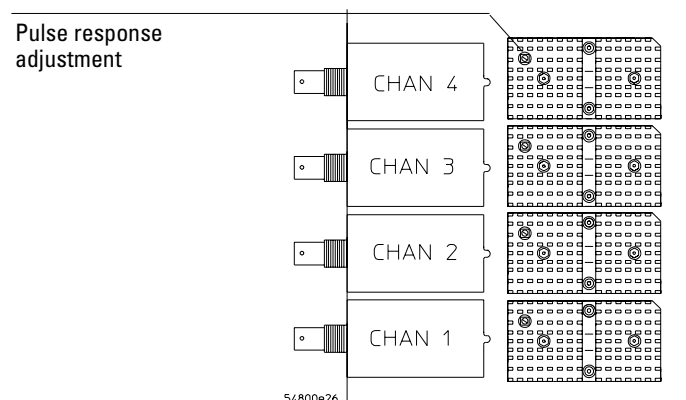

Pulse Response Adjustment

- 4 Press Default Setup.
- 5 Connect the auxiliary output to the input of the channel needing adjustment.
- 6 Press the appropriate channel number key to turn on the display for that channel. Turn all other channels off.
- 7 Use the input key to select  $50\Omega$  and the Coupling key to select DC.
- 8 Enable the graphical interface.
- 9 Set the sweep speed to 5 ns/div using the sweep speed knob.
- 10 Select the channel number from the Setup menu. Set the vertical scaling to 40 mV/div. Click Close.
- 11 Select Acquisition from the Setup menu. Select Equivalent Time sampling mode. Enable Averaging and set the number of points averaged to 4. Click Close.
- 12 If the grid is not already on, select Display from the Setup menu, click the On check box under Grid, and click Close.
- 13 If the pulse edge is not on the screen, adjust the horizontal position to set it near center screen.
- 14 Adjust the vertical position to place the flat part of the pulse top over the grid line, one division from the top of the display.

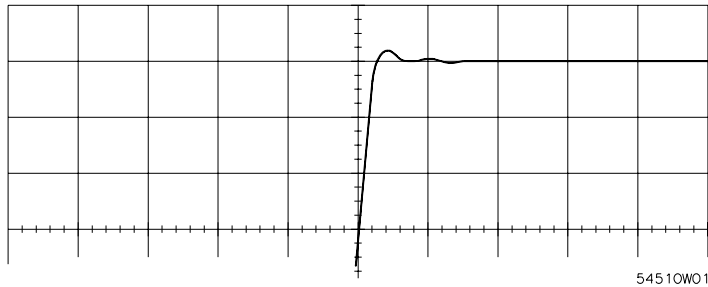

- 15 Adjust the resistor to extend the peak over the grid line, so that the overshoot is about 4%, a little less than one vertical minor division, as shown in the illustration. (One vertical minor division is about 4% of a six-division signal.)  
When the resistor is adjusted, the gain changes. You might need to use the vertical position control to reposition the pulse top to the grid line.  
There is no specification for pulse response. However, if overshoot is more than about 4%, use the resistor to reduce it slightly. If the instrument fails the bandwidth test, use the resistor to increase overshoot slightly.
- 16 If necessary, repeat steps 5 through 15 on any other channels needing adjustment.
- 17 If you have re-adjusted the pulse response, the channel gain has changed. You must recalibrate the channel (self cal) as given in the next procedure, "To run the self-calibration."
- 18 Perform the bandwidth test (see chapter 3, "Testing Performance") on any channels that have been adjusted.
- 19 Disconnect the power cord and replace the cover.

---

## To run the self-calibration

The self-calibration uses signals generated in the instrument to calibrate channel sensitivity, offsets, and trigger parameters. You should run the self-calibration

- yearly, or according to your periodic needs,
- when you adjust or replace the acquisition assembly or acquisition hybrids,
- when the delta temperature is more than  $\pm 10$  °C different than the last calibration, or
- after performing incoming performance verification and before performing outgoing performance verification.

---

### Equipment Required

Equipment	Critical Specifications	Recommended Model/Part
Cable	BNC 50 $\Omega$ , 9 inch	Agilent 10502A

#### Let Instrument Warm Up Before Running the Self Calibration

The Self-Calibration should only be done after the instrument has run for one half hour at ambient temperature with the cover installed. Calibration of an instrument that has not warmed up may result in performance test failure.

### Self-Calibration

#### Calibration Time

It will take approximately 15-20 minutes to calibrate the instrument, including the time required to change cables from channel to channel.

- 1 Enable the graphical interface.
- 2 Select Calibration from the Utilities menu.
- 3 If the Cal Memory Protect box in the Calibration dialog is checked, click on the check box to clear the check mark.

See figure 4-5.

Figure 4-5

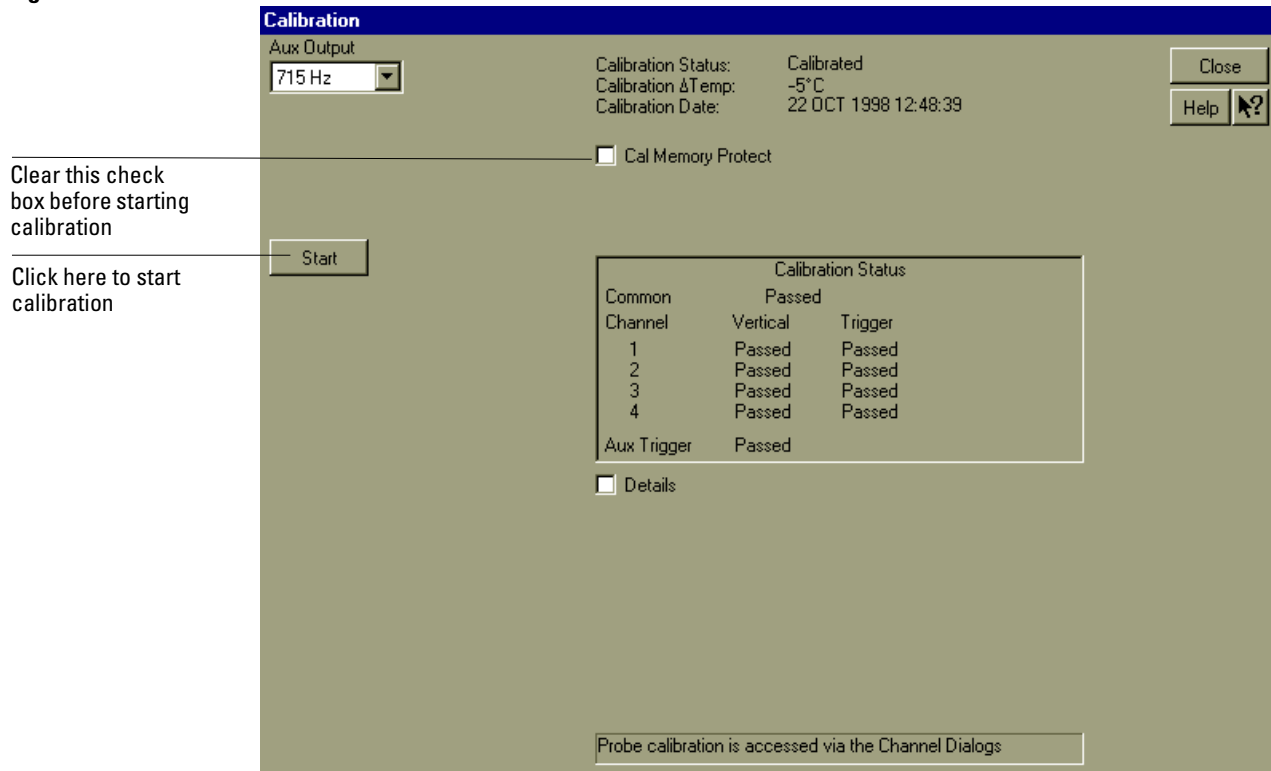

#### Calibration Dialog

##### Clear Cal Memory Protect

You cannot run self-calibration if the Cal Memory Protect box is checked.

- 4 Click the Start button, then follow the instructions on the screen.  
You will be asked first to disconnect all channels and the Aux Output, then to connect Aux Out to each channel in turn. After you complete each cable change, click OK in the dialog box to continue the calibration.  
The oscilloscope displays a Passed/Failed message as each calibration routine is completed.
- 5 After calibration has been completed, click in the Cal Memory Protect box to protect the calibration memory. Then click Close.

##### If calibration fails

Go to chapter 5 "Troubleshooting."

- Safety 5-2
- Tools Required 5-2
- ESD Precautions 5-2
- Keystroke Conventions 5-2
- Default Setup 5-3
  - To install the fan safety shield 5-3
  - To troubleshoot the instrument 5-3
- Primary Trouble Isolation 5-5
- No Display Trouble Isolation 5-8
- Power Supply Trouble Isolation 5-12
  - To check probe power outputs 5-15
  - To check the keyboard 5-16
    - Test Procedure 5-16
    - Troubleshooting Procedure 5-17
  - To check the LEDs 5-18
  - To check the motherboard, CPU, and RAM 5-20
  - To check the SVGA display board video signals 5-21
  - To check the backlight inverter voltages 5-22
- POST Code Listing (AMI Motherboard only) 5-23
  - To configure the motherboard jumpers and set up the BIOS 5-28
    - Motherboard / floppy drive configurations BIOS setup 5-28
    - Configuring the AMI Series 727 Motherboard Jumpers 5-30
      - To configure the AMI Series 727 WINBIOS Parameters 5-32
      - Configuring the AMI Series 757 Motherboard for 200 MHz CPU 5-34
      - To configure the AMI Series 757 WINBIOS Parameters with 1.44 Mbyte floppy drive 5-36
      - Configuring the AMI Series 757 Motherboard for 300 MHz CPU 5-39
      - To configure the AMI Series 757 WINBIOS Parameters with 120 Mbyte floppy drive 5-41
      - Configuring the FIC VA-503A motherboard switches for the 400 MHz CPU and 120 Mbyte floppy drive 5-44
      - To Configure the FIC Series VA-503A Motherboard BIOS Parameters 5-45
  - To troubleshoot the acquisition system 5-46
    - Determining the Acquisition Contact Closure Count 5-46
    - Isolating Acquisition Problems 5-46
  - To troubleshoot attenuator failures 5-53
    - Attenuator Click Test 5-53
    - Swapping Attenuators 5-54
    - Attenuator Connectivity Test 5-54
- Software Revisions 5-55

---

# Troubleshooting

This section provides troubleshooting information for the Agilent Technologies 54810A/15A/20A/25A oscilloscopes. The service strategy of this instrument is replacement of defective assemblies.

## Safety

Read the Safety Summary at the front of this manual before servicing the instrument. Before performing any procedure, review it for cautions and warnings.

---

### WARNING

#### SHOCK HAZARD!

Maintenance should be performed by trained service personnel aware of the hazards involved (for example, fire and electric shock). Lack of training and awareness of the hazards could result in electrical shock. When maintenance can be performed without power applied, the power cord should be removed from the instrument.

---

---

### WARNING

#### INJURY CAN RESULT!

Use caution when working around the cooling fan with the cover removed from the instrument. The cooling fan blades are exposed on one side and can be hazardous. Install the optional fan safety shield (Agilent P/N 54801-00601) to protect your fingers from the fan blades.

---

## Tools Required

You will need basic electronic troubleshooting tools, including a digital multimeter and a 100-MHz oscilloscope. Performance verification tests have more stringent requirements. See chapter 1 for the list of recommended test equipment.

If you need to remove and replace assemblies, you will need some of the hand tools listed in chapter 6, “Replacing Assemblies.”

## ESD Precautions

When using any of the procedures in this chapter, you should use proper ESD precautions. As a minimum, you should place the instrument on a properly grounded ESD mat and wear a properly grounded ESD wrist strap.

## Keystroke Conventions

To guide you while setting up the oscilloscope, the following conventions are used to represent keystrokes and other interactions with the instrument:

- When you need to issue a command through the graphical interface, the command will be phrased like this: “Select <command> from the <menu name> menu.”
- When you need to click on an object on the graphical interface, the instructions will be phrased something like this: “Click OK” or “Click the OK button.”
- When you need to press a key, the instructions will be phrased something like this: “Press Run” or “Press the Run key.”



### Default Setup

A Default Setup is provided to assure the instrument setup is in a known default state. The default setup prevents previous setups from interfering with the next test. It also simplifies the instrument setup procedure. Use the default setup when a procedure requires it.

- Press the Default Setup key to set the instrument to the default state.

---

## To install the fan safety shield

- 1 Disconnect the instrument power cord and remove the cover.  
If necessary, refer to the procedures in chapter 6, "Replacing Assemblies".
- 2 Clip the fan safety shield over the outside of the instrument chassis next to the fans.  
See figure 5-1.

Figure 5-1

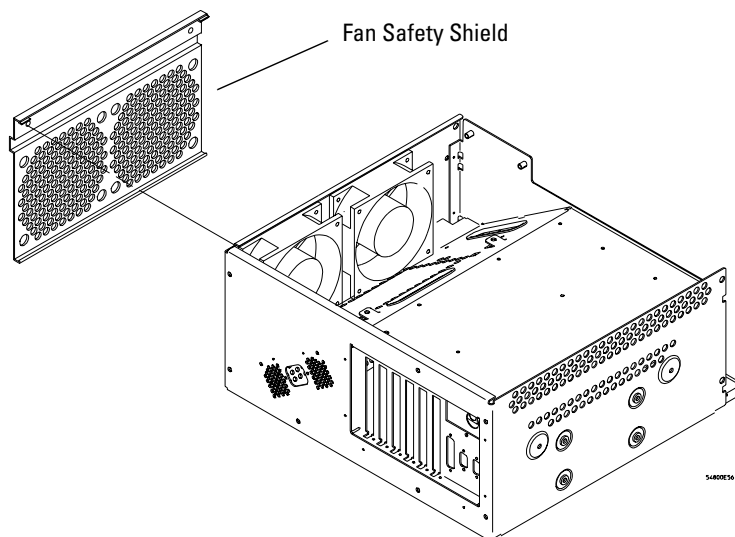

### Installing the Fan Safety Shield

---

## To troubleshoot the instrument

The troubleshooting procedure is used to isolate problems to a faulty assembly. When you find the faulty assembly, use the disassembly and assembly procedures in chapter 6 to replace the assembly.

The primary procedural tool in this section is the flowchart. The flowchart contains the entire troubleshooting path from a failed instrument to a working one, and will direct you in an orderly manner through the possible failure symptoms. Reference letters on the flowcharts point to procedural steps that explain the brief instructions in the chart. Do not try to troubleshoot by following only the reference text because the text is not in the correct order for troubleshooting. Instead, simply follow the flowchart.

If you are unfamiliar with this instrument, start with the Primary Trouble Isolation Flowchart on the next page.

## Chapter 5: Troubleshooting

### To troubleshoot the instrument

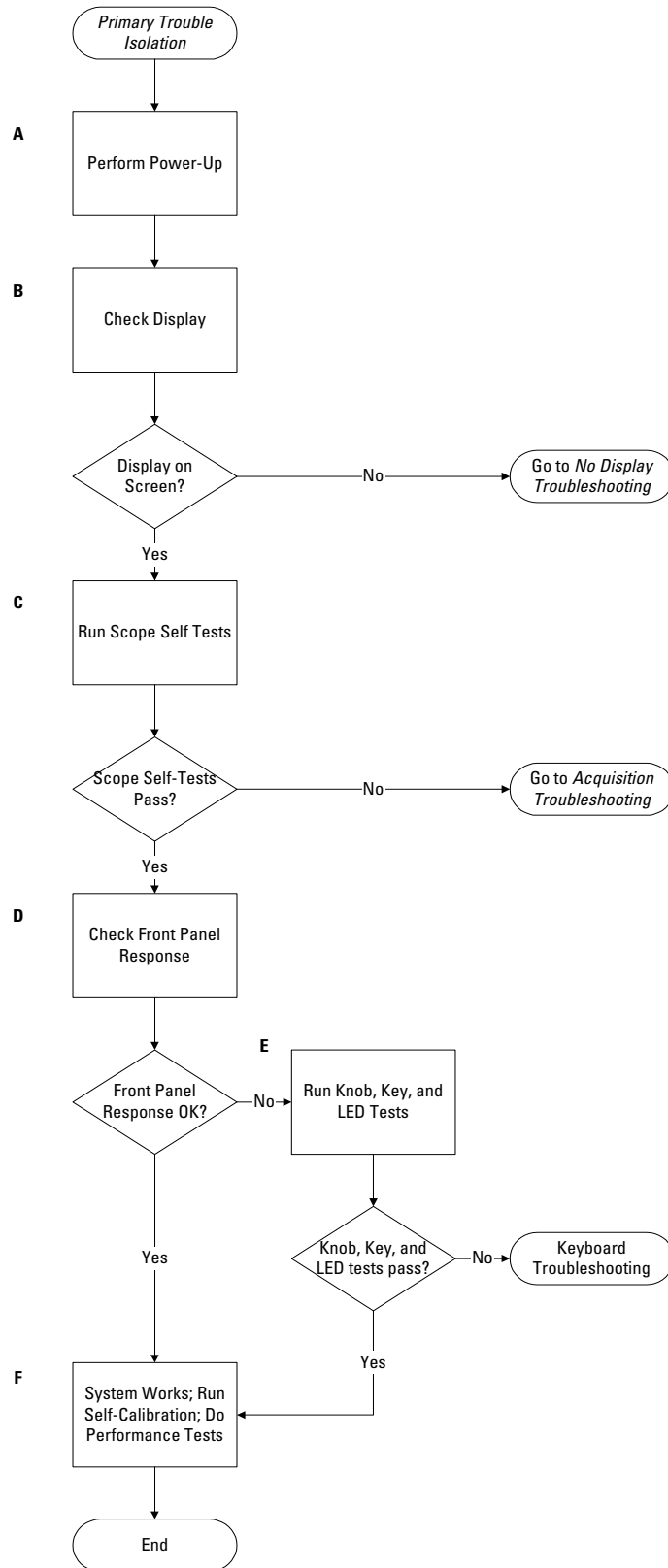

**Primary Trouble Isolation Flowchart**

---

## Primary Trouble Isolation

The actions in the Primary Trouble Isolation are done without disassembling the instrument. Interaction of the front panel with the rest of the instrument and other indicators are used to help identify the problem area.

A letter is assigned to boxes in the flowchart. The letter corresponds to a specific section in the reference text. Be sure to use the flowchart itself for your troubleshooting path.

### A Perform power-up.

#### 1 Power-on the instrument.

A short time after the instrument is turned on, the scope graticule is displayed on the screen. The screen should look similar to the next figure. The exact appearance may vary depending on the setup selected before the instrument was turned off.

Figure 5-2

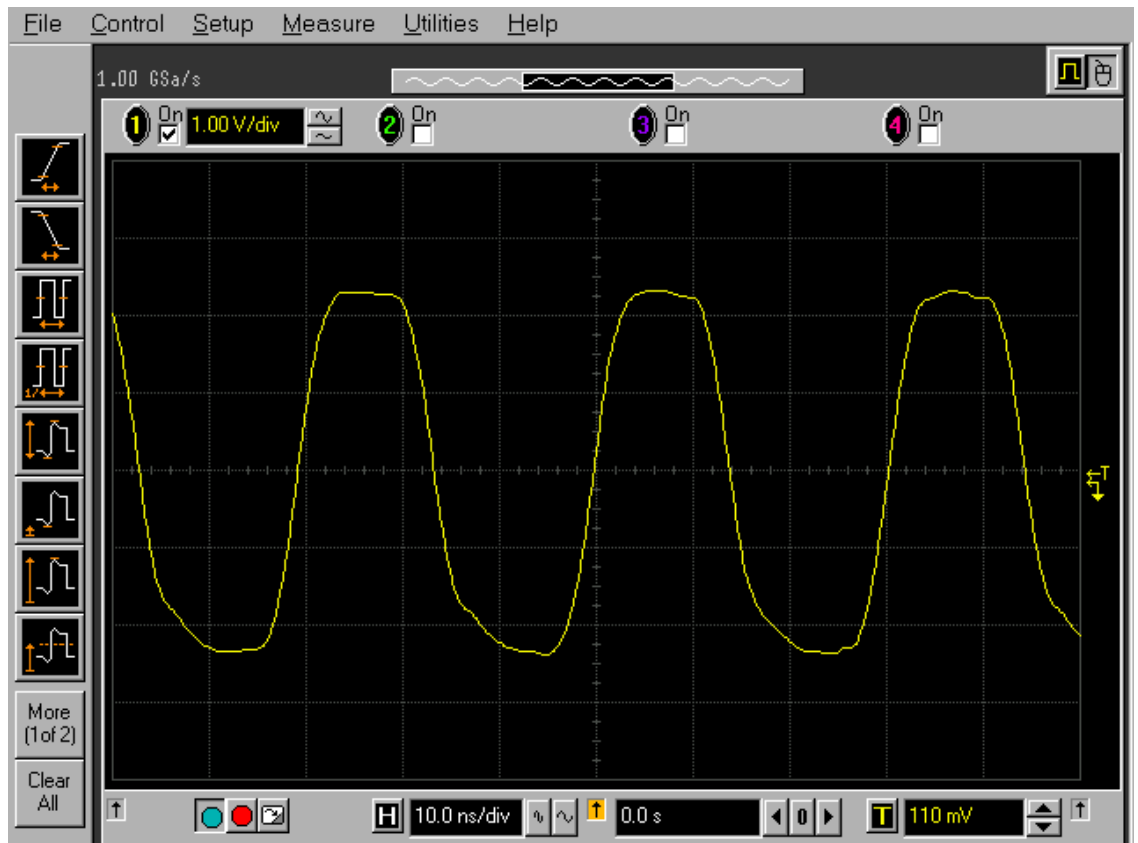

#### Power-on Display Default (Graphical Interface Disabled)

#### 2 Press the Default Setup key.

### B Check the display.

The display on the screen should be similar to the figure above. If there is no display on the oscilloscope flat-panel display after power-up, go to the No Display Trouble Isolation flowchart for further troubleshooting.

**C Run oscilloscope self-tests.**

- 1** Enable the graphical interface.
- 2** Select Self Test from the Utilities menu.
- 3** Select Scope Self Tests from the Self Test drop down list box.
- 4** Click the Start Test button and follow the instructions on the screen.

If any of the self-tests fail, go to the Acquisition Trouble Isolation troubleshooting flowchart later in this chapter for further troubleshooting. Otherwise, go to step D.

**D Check the front panel.**

Randomly press the front panel keys and rotate the knobs to verify that they work correctly. If any fail to work, run the Knob and Key self-test and the LED self-test in step E.

**E Run the Knob and Key self-test and the LED self-test.**

- 1** Enable the graphical interface.
- 2** Select Self Test from the Utilities menu.
- 3** Select the Knob and Key self-test from the Self Test drop down list box.
- 4** Click the Start test button and follow the instructions on the screen.

If any of the knobs or keys do not work, go to “To check the keyboard” later in this chapter.

- 5** Select the LED self-test from the Self Test drop down list box.
- 6** Click the Start test button and follow the instructions on the screen.

If any of the LEDs do not work, go to “To check the LEDs” later in this chapter.

**F The system is operational. Performance test the oscilloscope using the procedures in chapter 3 of this service manual.**

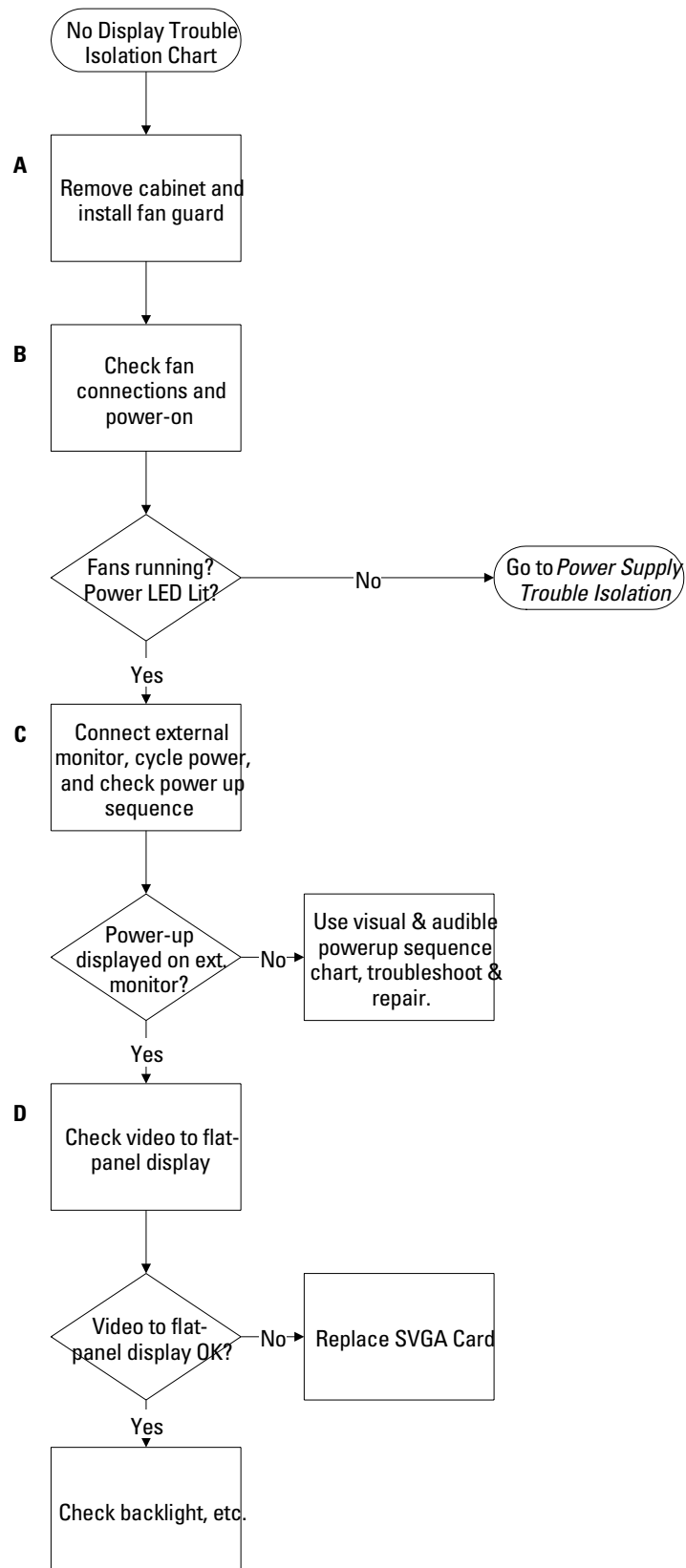

**No Display Trouble Isolation Flowchart**

---

## No Display Trouble Isolation

This trouble isolation procedure helps isolate a problem to the assembly level when there is no display on the flat-panel liquid crystal display screen.

**A Remove the cabinet and install the fan safety shield.**

- 1** Disconnect the power cord from the oscilloscope. Refer to chapter 6, "Replacing Assemblies," for instructions on removing the cabinet. Use care in handling the instrument.
- 2** Install the optional fan safety shield, Agilent P/N 54801-00601, over the fans on the left side of the instrument.

---

**WARNING**

**SHOCK HAZARD!**

The backlight inverter assembly, which is mounted at the front corner of the instrument near the flat-panel display, operates at 900 V. DO NOT handle this assembly while it is in operation.

---

**WARNING**

**INJURY CAN RESULT!**

Once the cover is removed, the fan blades are exposed both inside and outside the chassis. Disconnect the power cable before working around the fan. Use extreme caution in working with the instrument when the cover is removed. Install the fan safety shield (Agilent P/N 54801-00601) on the side of the chassis over the fan. Failure to observe these precautions may result in injury.

- 3** Connect the power cord and press the power switch on the front panel.

**B Check the fan connections.**

Verify that the fan mounted in the left side of the instrument and the CPU fan (on the motherboard) are connected.

- 1** The instrument fan connects to the bottom side of the Acquisition assembly at J15 (FAN).
- 2** The CPU fan connects to the top side of the motherboard at J46 (Fan Power).
- 3** Connect the power cord and press the power switch on the front panel. Verify that both fans are running and that the front panel power switch LED is illuminated. These are indications that the power supply is functioning. If the fans and LED are off, go to the Power Supply Trouble Isolation flowchart.

**C Connect an external monitor, cycle power, and observe the instrument power-on sequence.**

See table 5-1 to check the visual and audible power-on sequence, and repair as needed, referring to other procedures as directed.

**Table 5-1**

Power-On Sequence with External Monitor Connected

Time	Audible Indicators	Visible Indicators	Description	Troubleshooting
1	Power-on		Power-on the instrument and listen for the fans and the hard disk drive. The hard disk is located behind the floppy drive against the chassis side wall.	
2	Fans begin running	Power switch LED illuminates	The main instrument fan and the CPU fan start running at power on. The LED located behind the front panel power switch is connected to the +5 V supply, making it a good power supply indicator.	You will need to use a DMM to verify that the supply voltages are within specifications. If the power supplies do not come up, go to the "Power Supply Trouble Isolation" flowchart.
3	HDD (hard disk drive) begins turning	Front panel LEDs come up in power-on pattern	The front panel LEDs display their power-up pattern. The following trigger LEDs should all come on at the same time: Edge, Glitch, Advanced, Positive and Negative slope, DC, AC, LF Reject, and HF Reject. This pattern indicates that the front panel keyboard has completed its power-on test.	If the LEDs do not come on, check the cabling to the front panel board and check for +5 V on pin 2 of the 10-pin conductor keyboard cable W16. Also check for +5 V on the scope interface card A6. If the +5 V is at the scope interface card but the front panel LEDs do not come on, the problem is the cable or the front panel keyboard A7.
			The hard disk drive (HDD) starts spinning at power on. Listen at the top right rear of the instrument for a higher-pitched whine; this is the HDD coming up to speed. Shortly after the disk comes up to speed, you should hear a brief burst of clicks*; this sound is part of the disk's power-up self-check routine.	If the HDD is not responding, check the cabling. If the disk is turning, but you do not hear the brief burst of clicks* after the disk comes up to speed, the circuitry onboard the disk drive may be at fault. If the motherboard (including CPU and RAM) are functioning but the HDD is not responding, the external VGA monitor will usually show the message "16000 KB OK, WAIT..." followed by the message "Pri Master HDD Error, RUN SETUP, Press F1 to Resume." See the section on "To configure the motherboard jumpers and set up the BIOS" for information on how to access and run the setup program. If, after running setup, there is still a problem, check the cabling for the hard disk drive, both between the motherboard and SVGA display board, and between the SVGA display board and the HDD. If the cabling is OK, see the section on verifying motherboard operation; otherwise, replace the HDD.

\* Later model hard disk drives are much quieter than earlier models. The clicking can only be heard with the instrument sleeve removed and in close proximity to the hard disk drive.

Chapter 5: Troubleshooting  
**No Display Trouble Isolation**

Time	Audible Indicators	Visible Indicators	Description	Troubleshooting
4	HDD clicking*	PC Power-On Self Test (POST) memory test message on external monitor.	The HDD begins clicking* as it is accessed by the system. The external SVGA monitor shows the POST messages. These messages show the memory test.	If there is no display on the external monitor, either the motherboard A4 (including CPU or RAM), the SVGA display board, cabling, or external VGA monitor are suspect. Check the cabling and VGA monitor first. Next, use a POST (Power-On Self Test) card to help isolate the no-display problem. Install the POST card in an ISA slot and apply power to the instrument. The POST card displays the respective codes as the power-on self tests are completed. See the "POST Code Listing" in this chapter for codes and descriptions. Replace the motherboard, CPU, or RAM as indicated from the POST code listing.
5	HDD clicking*	System board configuration appears on external monitor and internal display.	The HDD continues clicking* as the instrument loads the oscilloscope application. The flat panel LCD backlight comes on and the display shows the system board configuration. This is an indication that the motherboard and SVGA display board are functioning correctly.	
6	HDD clicking*	The Infinium display appears on the internal and external displays.	The HDD continues clicking.*	
7	Attenuators click as solenoids are preset to known states	Front panel LEDs change to a normal operating pattern. Both screens go blank momentarily.	The attenuators click. This is louder than the HDD clicking and comes from the front of the instrument. The front panel LEDs change to a normal operating pattern. For example, the Trigger LEDs show only one trigger mode, such as Edge, and one trigger coupling, such as dc.	
8	Attenuators click to their operating states (second interval, indicates scope running)	Oscilloscope display comes up on both the external monitor and the scope's front panel display.	The attenuators click a second time. The oscilloscope display backlight comes on, and the display appears on both the external monitor and the scope's front panel display. The oscilloscope is running.	If the attenuators click a second time but the display does not come up, try the front panel keys to see whether they respond. If so, there is a display problem. If the external monitor shows the screen but the oscilloscope does not, the problem may be with cabling, the backlight inverter board A3 not supplying +900V and +12 V, the flat-panel display A2, or the SVGA display board A5. See the sections "To check the backlight inverter voltages" and "To check the SVGA display board video signals."

\* Later model hard disk drives are much quieter than earlier models. The clicking can only be heard with the instrument sleeve removed and in close proximity to the hard disk drive.



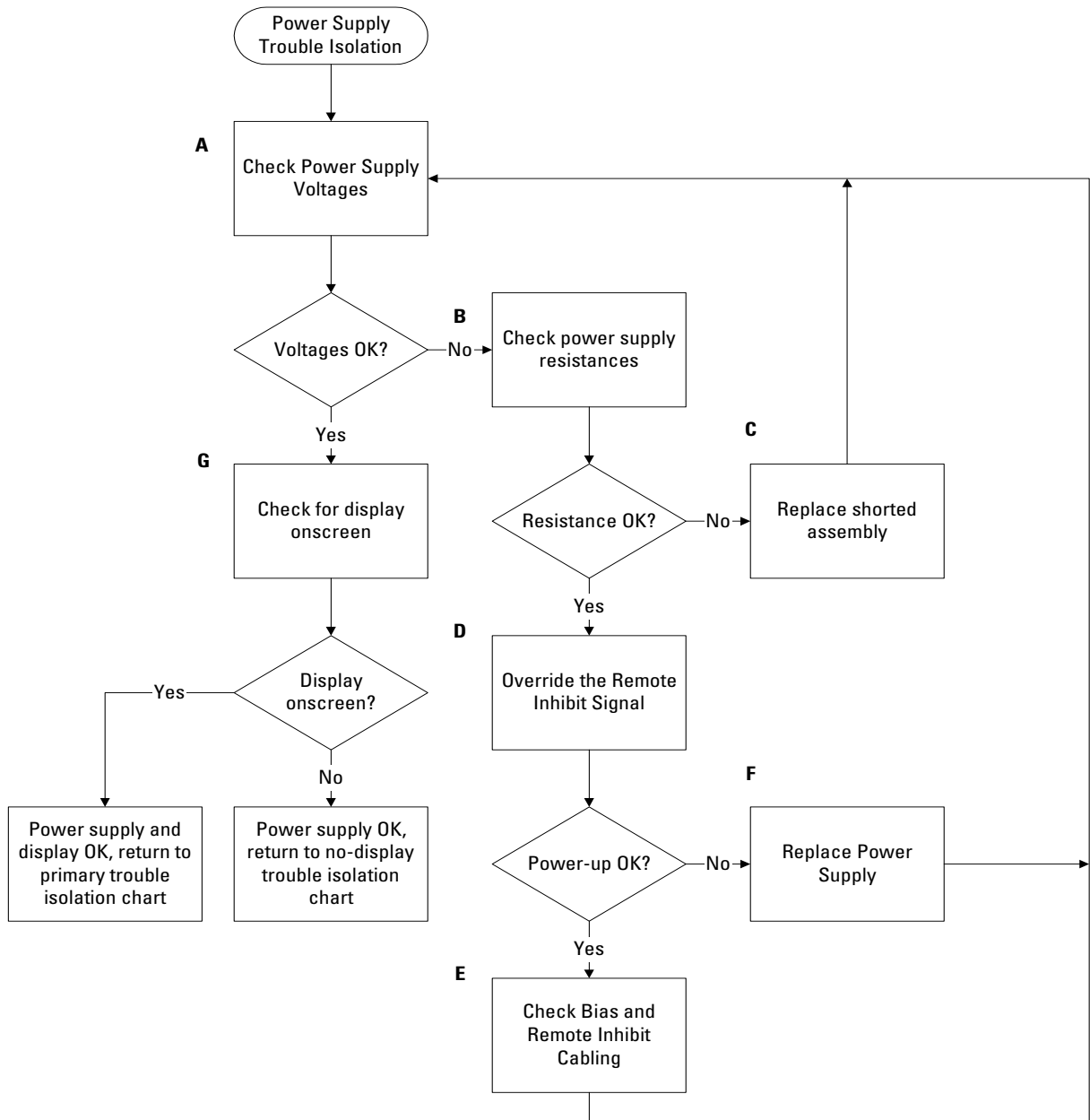

**Power Supply Trouble Isolation Flowchart**

## Power Supply Trouble Isolation

These trouble isolation instructions help isolate the problem to the assembly level when the power supply is not operating. Because of advanced power supply protection features, the problem may not be with the supply itself, and therefore you will need to work through the procedure systematically to determine the source of the fault.

**A Check the power supply voltages.**

You check the power supply voltages on the acquisition board, A13. See figure 5-3 for the location of these test points. Table 5-2 shows the allowable range of power supply voltages.

**Figure 5-3**

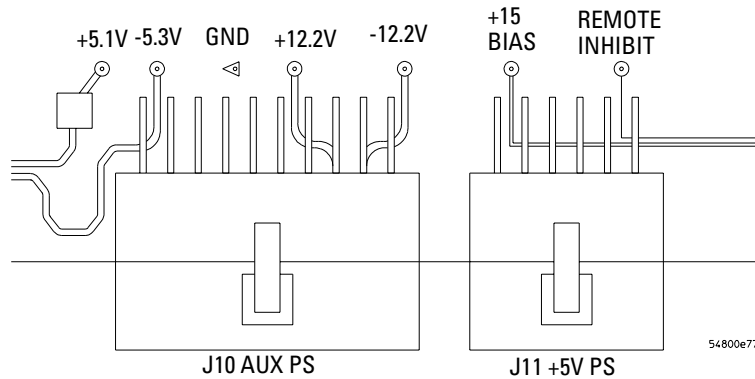

**Power Supply Voltage Test Locations (A13)**

**Table 5-2**

<b>Power Supply Voltage Limits</b>	
<b>Supply Voltage Specification</b>	<b>Limits</b>
+5.1 V ± 0.1 V	+5.0 V to +5.2 V
-5.3 V ± 0.1 V	-5.2 V to -5.4 V
+12.2 V ± 0.3 V	+11.9 V to +12.5 V
-12.2 V ± 0.3 V	-11.9 V to -12.5 V

**B Turn off the power and measure the power supply resistances to ground to check for shorted supply lines.**

You can probe the test points on A13, shown in figure 5-3, for this resistance check. Table 5-3 shows the characteristic resistance values for the Agilent Technologies 54810A/15A/20A/25A oscilloscopes.

**Table 5-3**

<b>Approximate Resistance Values, Each Power Supply to Ground</b>	
<b>Supply</b>	<b>Approximate Resistance to Ground</b>
+12 V	365Ω
-12 V	285Ω
-5.3 V	23Ω
+5.1 V	46Ω

**C Replace any shorted assembly.**

You can locate the shorted assembly by disconnecting assemblies from the power supply, one at a time. Use the power supply distribution chart in table 5-4 as a guide to locating the shorted assembly.

**Reconnect Assemblies and Cables**

Reconnect all assemblies after testing. The oscilloscope must have all cables connected for correct power-up.

If you want to test the power supply without any assemblies connected, the +5 V supply must be loaded to 2 A. Use two 5Ω, 10W resistors between the +5 V output and ground.

**Table 5-4**

**Power Supply Distribution**

Assembly	+5.1 V	-5.3 V	Ground	+12.2 V	-12.2 V	3.3 V (generated on Motherboard)
Acquisition	X	X	X	X	X	
Motherboard	X	X	X	X	X	X
Probe Power & Control	X		X	X	X	
Front-Panel Keyboard	X		X			
Scope Interface Board	X		X			X
Display Board	X		X	X	X	X
Backlight Inverter			X	X		
Flat Panel Display	X		X			X
Floppy Disk Drive	X		X			
Hard Disk Drive	X		X			

**D Override the Remote Inhibit signal.**

Power up the unit by connecting a resistor between pin 3 and pin 11 of power supply control cable W2. Use a resistor in the range of 196-220Ω, 1/8 W, such as Agilent P/N 0698-3440 or Agilent P/N 0757-0407.

See figure 5-4.

**Figure 5-4**

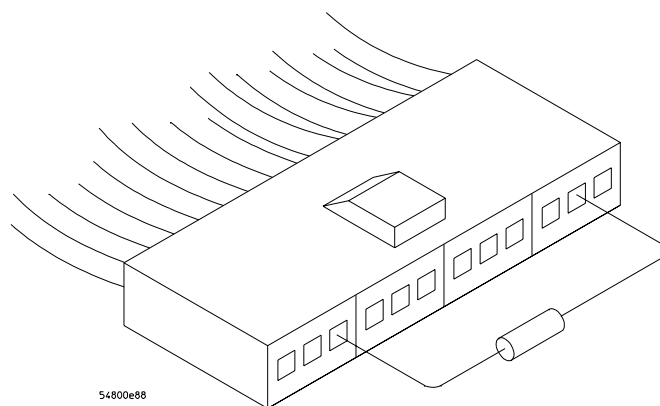

**Power-up Sense Resistor Connection**

**E Check +15 V Bias and Remote Inhibit cabling.**

If the oscilloscope will not power up, check all cabling to troubleshoot and correct the problem. Figure 5-5 shows the routing of the +15 V Bias and Remote Inhibit signals from the front panel to the power supply. The power supply is on only when the remote inhibit signal is between +1 V and +5 V. A problem could be caused by a faulty cable or bad connector anywhere in this path. Check all the cables and connections and replace any at fault.

**Figure 5-5**

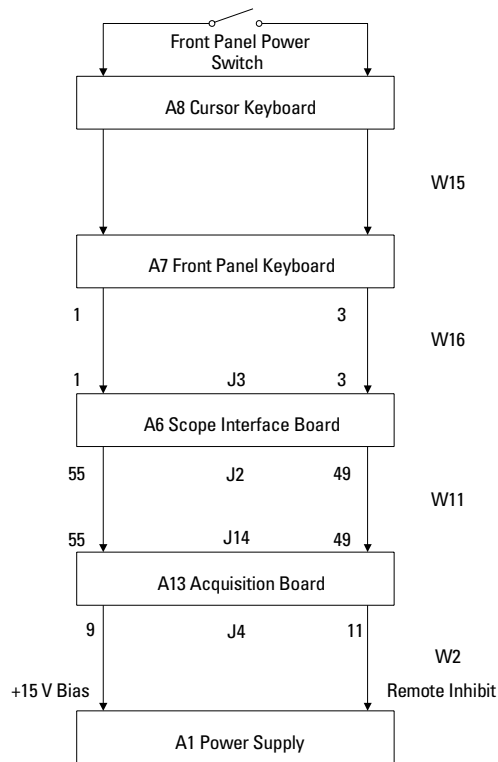

**Routing of +15 V Bias and Remote Inhibit Signals**

**F Replace the power supply.**

- 1 If the +15 V bias is correct, but the instrument will not power up with a 196-220 $\Omega$  resistor, replace the power supply. Chapter 6 explains how to remove and replace the power supply.
- 2 Re-assemble the instrument and apply power.

**G Check for the oscilloscope display on the screen.**

- 1 You should see the oscilloscope display (see figure 5-2). If not, see the No Display Trouble Isolation Flowchart.
- 2 If you see the display, return to the Primary Trouble Isolation Flowchart.

## To check probe power outputs

Probe power outputs are on the front panel, surrounding each BNC input.

Use the table and figure to the right to check the power output at the connectors.

The +12 V and –12 V supplies come directly from the power supply. The +3 V and –3 V supplies are developed in three-terminal regulators on the probe power & control assembly.

Measure the voltages with respect to the ground terminal on the front panel, located near the Aux Out BNC.

Do not attempt to measure voltages at pins 3 through 7.

Pin	Supply
1	+3V
2	–3V
3	Offset
4	Data
5 & ring	Probe ID
6	Clk
7	R <sub>p</sub>
8	–12 V
9	+12 V

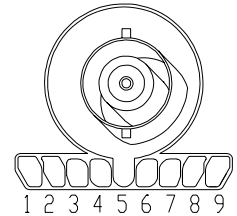

Any failure may be a problem with the probe power and control assembly, the AutoProbe flex cable W13, or the probe power and control cable W12.

## To check the keyboard

### Test Procedure

Use this procedure to verify correct keyboard operation.

- 1 Enable the graphical interface.
- 2 Select Self Test from the Utilities menu.
- 3 Select Knob and Key from the Self Test drop down list box, then click Start.  
A new window appears with a symbolic representation of the keyboard. See figure 5-6.

Figure 5-6

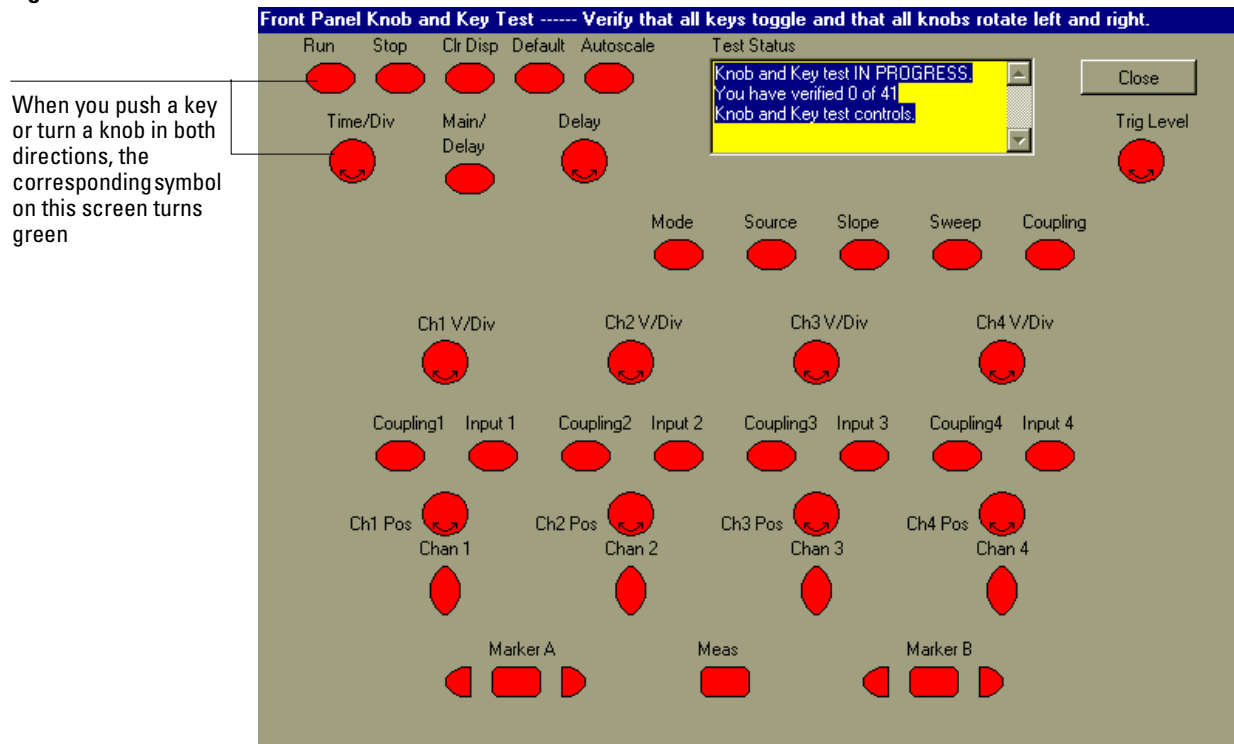

### Knob and Key Self Test Screen

- 4 Push each key on the keyboard until you have pushed all keys.  
When you push a key, the corresponding key symbol on the display should change from red to green.
- 5 Turn each knob in both directions until you have turned all knobs.  
When you turn a knob in one direction, the corresponding knob symbol on the display should change from red to yellow. When you then turn the knob in the other direction, the knob symbol should change from yellow to green.
- 6 When you are finished, click Close.  
If any knob failed, you should replace the keyboard assembly. If you encounter any key failures, record the location of those failures, then go to the troubleshooting procedure that follows.

### Troubleshooting Procedure

Use this procedure only if you encounter key failures in the keyboard test procedure. If any knobs fail, replace the keyboard assembly.

- 1** Disconnect the power cord and remove the cover.
- 2** Remove the front panel assembly.  
See chapter 6 for instructions.
- 3** Remove the keyboard assembly and the cursor keyboard assembly from the front panel assembly. Partially re-assemble the front panel assembly, including the flat-panel display and lens, but omitting the keyboard and cursor keyboard. Re-attach the partial assembly to the chassis.  
Be sure to reconnect the display video cable and the backlight inverter cables. See chapter 6 for instructions on removing and disassembling the front panel.
- 4** Separate the elastomeric keypads from the cursor keyboard and keyboard assemblies.

---

**CAUTION**

---

CONTAMINATION CAN CAUSE INTERMITTENT OPERATION!

Be careful not to contaminate the key side of the PC board or the keypads. Dust and fingerprints on these parts may cause intermittent key operation.

- 5** Set the cursor keyboard and keyboard assembly on an antistatic electrical insulated surface.
- 6** Connect the cursor keyboard cable to the keyboard assembly. Connect the keyboard cable to the scope interface board in the chassis.  
You may need to set the chassis on its side to allow proper routing of the cables without straining them.
- 7** Reconnect the power cable and apply power.
- 8** Enable the graphical interface, then start the keyboard test as described in the previous procedure.
- 9** Carefully short the PC board trace, with a paper clip or screwdriver, at each non-operating key (as determined by the keyboard test), and look for an appropriate response on the display.
  - If the display responds as though a key were pressed, replace the elastomeric keypad.
  - If the display does not respond as though a key were pressed, replace the keyboard.
- 10** Re-assemble the instrument.

## To check the LEDs

Use the following procedure to test the front-panel LED (light-emitting diode) indicators.

- 1 Enable the graphical interface.
- 2 Select Self Test from the Utilities menu.
- 3 Select LED from the Self Test drop-down list box, then click Start Test.

The LED test screen appears, which shows a symbolic representation of all front panel LED indicators. See figure 5-7.

Figure 5-7

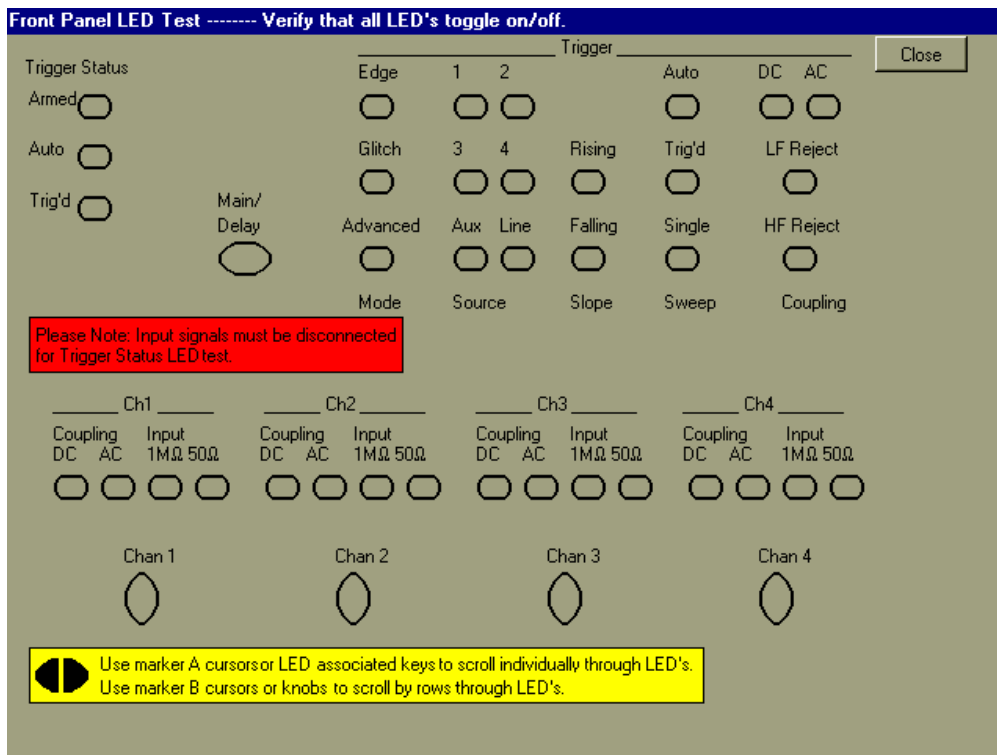

### LED Test Screen

- 4 Push the Marker A left and right arrow keys to highlight each LED symbol in the test screen. Verify that the corresponding LEDs on the front panel are the only ones illuminated.

### Test by Rows

You can use the Marker B arrow keys to test LEDs by row; however, in the event that two LED indicators are shorted together, there is a small chance that the test will not reveal the failure.



**5** When you are finished, click Close.

If you see a failure with the Auto or Trig'd LEDs, check the voltage at pin 6 of W16, with W16 disconnected from the keyboard. The voltage should be as follows:

- 0 V  $\pm$ 0.5 V when both LEDs are supposed to be off.
- 2.5 V  $\pm$ 0.5 V when Trig'd is supposed to be on and Auto is supposed to be off.
- 5.0 V  $\pm$ 0.5 V when both LEDs are supposed to be on.

If the voltages are not correct, the problem may be with keyboard cable W16, scope interface board A6, acquisition cable W11, or acquisition board W13. Try troubleshooting the acquisition system first to verify correct behavior before replacing any assemblies. If the voltages are correct but the LEDs do not light correctly, replace the keyboard assembly.

If you find a problem with the Armed LED, check pin 5 of W16 with the cable disconnected from the keyboard. The voltage should be as follows:

- 5.0 V  $\pm$ 0.5 V when Armed is supposed to be on.
- < 3.6 V  $\pm$ 0.5 V when Armed is supposed to be on.

Isolation is the same as for the Trig'd and Auto LEDs.

If you find any other failure, replace the keyboard assembly. If the front panel power indicator LED does not light, replace the cursor keyboard assembly.

## To check the motherboard, CPU, and RAM

This procedure verifies that the PC system board and the associated CPU and RAM are functioning. It assumes that the power supply, SVGA display board, and an external VGA monitor are functioning correctly.

- 1 Connect an external keyboard to the keyboard port.
- 2 Connect an external VGA monitor to the VGA output connector on the rear panel.
- 3 Hold down the Insert key on the external keyboard, then apply power to the oscilloscope.
- 4 Verify that a message, such as the following, appears on the external monitor:

```
AMI Atlas-III PCI/ISA  
AMD-K6(tm) - /200  
Checking NVRAM  
16000 KB OK
```

```
WAIT...
```

```
<INS> Pressed
```

```
RUN SETUP  
Press F1 to Resume
```

### **Messages Vary Slightly**

These messages may vary slightly depending on the motherboard version.

If the above message is displayed, you can assume that the PC system board, CPU, and RAM are functioning correctly.

If the message is not displayed or there is no display, remove the GPIB interface board and LAN interface board and try the test again. Procedures to remove the interface boards are given in chapter 6, “Replacing Assemblies.”

If you need to run setup, press F1 (see “To configure the motherboard jumpers and set up the BIOS” for information). Otherwise, turn off power and proceed with troubleshooting.

## To check the SVGA display board video signals

The video signals are checked on the 40-pin connector J103 on the SVGA display board A5. Use a 100-MHz, general-purpose oscilloscope, such as the Agilent 54600B, to verify the signals. Even-numbered pins are on the top side of the connector. The video signals are present during the system boot process before the backlights come on. If the signals are not present, suspect the display card. If the signals are present and the backlights are on, suspect the flat-panel display as the problem.

**Table 5-5**

**Video Signals**

Pin Number	Signal
1-2	+3.3 V
3, 5-6	NC
4, 7-9, 11, 15, 19, 23, 27, 31, 35, 38, 40	Ground
12-14, 16-18	Blue video
20-22, 24-26	Green video
28-30, 32-34	Red video
10	Panel enable
36	Panel HSync
37	Panel VSync
39	Panel Clk

**Figure 5-8**

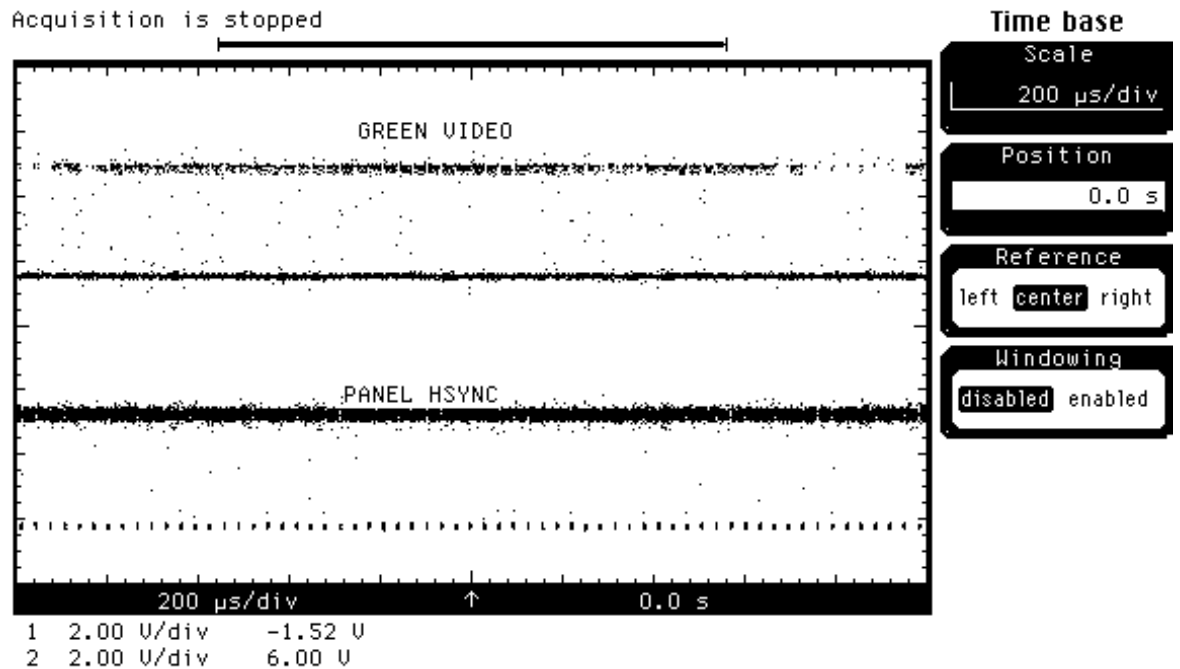

**Video Signals**

---

## To check the backlight inverter voltages

The backlight inverter board A3 is located in the front-left corner of the oscilloscope (as you face the front panel).

- There is one input connector on the side of the board.
- There are two output connectors, one at each end of the board (top and bottom), which power the two backlights inserted into the flat panel display.

The output voltage is approximately 300-450 V<sub>rms</sub>, 40 kHz (measured differentially between the two wires) when the backlight is illuminated. The voltage is approximately 1 kV before the backlight tube is illuminated.

The outputs are controlled by the input. Notice that input pin 5 goes low to enable the output voltage. These pins can be reached at J1 on the SVGA display board A5.

**Table 5-6**

---

**Backlight Inverter Board Input Voltages**

---

Input Pin #	7	6	5	4	3	2	1
Backlight OFF	0 V	0 V	12 V	0 V	0 V	12 V	12 V
Backlight ON	0 V	0 V	0 V	0 V	0 V	12 V	12 V

---

## POST Code Listing (AMI Motherboard only)

Use the following listing to troubleshoot the motherboard. You will need a POST (Power-On Self Test) card installed in an ISA slot to use this listing.

---

### POST Code Listing

#### Checkpoint

Code	Description
D0h	The NMI is disabled. Power on delay is starting. Next, the initialization code checksum will be verified.
D1h	Initializing the DMA controller.
D3h	Starting memory sizing next.
D4h	Returning to real mode. Executing any OEM patches and setting the stack next.
D5h	Passing control to the uncompressed code in shadow RAM at E000:0000h. The initialization code is copied to segment 0 and control will be transferred to segment 0.
D6h	Control is in segment 0. Next, checking if Home was pressed and verifying the BIOS checksum. If either Home was pressed or the system BIOS checksum is bad, next will go to checkpoint code E0h. Otherwise, going to checkpoint code D7h.

#### Bootblock Recovery Codes

The bootblock recovery checkpoint codes are listed in order of execution:

Code	Description
E0h	The onboard floppy controller, if available, is initialized. Next, beginning the base 512 KB memory test.
E1h	Initializing the interrupt vector table next.
E2h	Initializing the DMA and Interrupt controllers next.
E6h	Enabling the floppy drive controller and Timer IRQs. Enabling internal cache memory.
EDh	Initializing the floppy drive.
EEh	Looking for a floppy diskette in drive A:. Reading the first sector of the diskette.
EFh	A read error occurred while reading the floppy disk in drive A:.
E0h	Next, searching for the AMIBOOT.ROM file in the root directory.
F1h	The AMIBOOT.ROM file is not in the root directory.
F2h	Next, reading and analyzing the floppy diskette FAT to find the clusters occupied by the AMIBOOT.ROM file.
F3h	Next, reading the AMIBOOT.ROM file, cluster by cluster.
F4h	The AMIBOOT.ROM file is not the correct size.
F5h	Next, disabling internal cache memory.
FBh	Next, detecting the type of flash ROM.
FCh	Next, erasing the flash ROM.
FDh	Next, programming the flash ROM.
FFh	Flash ROM programming was successful. Next, restarting the system BIOS.

## Chapter 5: Troubleshooting

### POST Code Listing (AMI Motherboard only)

#### Uncompressed Initialization Codes

The following runtime checkpoint codes are listed in order of execution. These codes are uncompressed in F0000h shadow RAM.

#### Checkpoint

Code	Description
03h	The NMI is disabled. Next, checking for a soft reset or a power on condition.
05h	The BIOS stack has been built. Next, disabling cache memory.
06h	Uncompressing the POST code next.
07h	Next, initializing the CPU and the CPU data area.
08h	The CMOS checksum calculation is done next.
0Ah	The CMOS checksum calculation is done. Initializing the CMOS status register for date and time next.
0Bh	The CMOS status register is initialized. Next, performing any required initialization before the keyboard BAT command is issued.
0Ch	The keyboard controller input buffer is free. Next, issuing the BAT command to the keyboard controller.
0Eh	The keyboard controller BAT command result has been verified. Next, performing any necessary initialization after the keyboard controller BAT command test.
0Fh	The initialization after the keyboard controller BAT command test is done. The keyboard command byte is written next.
10h	The keyboard controller command byte is written. Next, issuing the Pin 23 and 24 blocking and unblocking command.
11h	Next, checking if keys were pressed during power on. Initializing CMOS RAM if the Initialize CMOS RAM in every boot AMIBIOS POST option was set in AMIBCP or the key was pressed.
12h	Next, disabling DMA controllers 1 and 2 and interrupt controllers 1 and 2.
13h	The video display has been disabled. Port B has been initialized. Next, initializing the chipset.
14h	The 8254 timer set will begin next.
19h	The 8254 timer test is over. Starting the memory refresh test next.
1Ah	The memory refresh line is toggling. Checking the 15 second on/off time next.
23h	Reading the 8042 input port and disabling the MEGAKEY Green PC feature next. Making the BIOS code segment writable and performing any necessary configuration before initializing the interrupt vectors.
24h	The configuration required before interrupt vector initialization has completed. Interrupt vector initialization is about to begin.
25h	Interrupt vector initialization is done. Clearing the password if the POST DIAG switch is on.
27h	Any initialization before setting video mode will be done next.
28h	Initialization before setting the video mode is complete. Configuring the monochrome mode and color settings next.
2Ah	Bus initialization system, static, output devices will be done next, if present.
2Bh	Passing control to the video ROM to perform any required configuration before the video ROM test.
2Ch	All necessary processing before passing control to the video ROM is done. Looking for the video ROM next and passing control to it.
2Dh	The video ROM has returned control to BIOS POST. Performing any required processing after the video ROM had control.

2Eh	Completed post-video ROM test processing. If the EGA/VGA controller is not found, performing the display memory read/write test next.
2Fh	The EGA/VGA controller was not found. The display memory read/write test is about to begin.
30h	The display memory read/write test passed. Look for retrace checking next.
31h	The display memory read/write test or retrace checking failed. Performing the alternate display memory read/write next.
32h	The alternate display memory read/write test passed. Looking for alternate display retrace checking next.
34h	Video display checking is over. Setting the display mode next.
37h	The display mode is set. Displaying the power on message next.
38h	Initializing the bus input, IPL, general devices next, if present.
39h	Displaying bus initialization error messages.
3Ah	The new cursor position has been read and saved. Displaying the Hit message next.
3Bh	The Hit message is displayed. The protected mode memory test is about to start.
40h	Preparing the descriptor tables next.
42h	The descriptor tables are prepared. Entering protected mode for the memory test next.
43h	Entered protected mode. Enabling interrupts for diagnostics mode next.
44h	Interrupts enabled if the diagnostics switch is on. Initializing data to check memory wraparound at 0:0 next.
45h	Data initialized. Checking for memory wraparound at 0:0 and finding the total system memory size next.
46h	The memory wraparound test is done. Memory size calculation has been done. Writing patterns to test memory next.
47h	The memory pattern has been written to extended memory. Writing patterns to the base 640 KB memory test.
48h	Patterns written in base memory. Determining the amount of memory below 1 MB next.
49h	The amount of memory below 1 MB has been found and verified. Determining the amount of memory above 1 MB next.
4Bh	The amount of memory above 1 MB has been found and verified. Checking for a soft reset and clearing the memory below 1 MB for the soft reset next.
4Ch	The memory below 1 MB has been cleared via a soft reset. Clearing the memory above 1 MB next.
4Dh	The memory above 1 MB has been cleared via a soft reset. Saving the memory size next. Going to checkpoint 52h next.
4Eh	The memory test started, but not as the result of a soft reset. Displaying the first 64 KB memory size next.
4Fh	The memory size display has started. The display is updated during the memory test. Performing the sequential and random memory test next.
50h	The memory below 1 MB has been tested and initialized. Adjusting the displayed memory size for relocation and shadowing next.
51h	The memory size display was adjusted for relocation and shadowing. Testing the memory above 1 MB next.
52h	The memory above 1 MB has been tested and initialized. Saving the memory size information next.
53h	The memory size information and the CPU registers are saved. Entering real mode next.
54h	Shutdown was successful. The CPU is in real mode. Disabling the Gate A20 line, parity, and NMI.

Chapter 5: Troubleshooting  
**POST Code Listing (AMI Motherboard only)**

57h	The A20 address line, parity, and the NMI are disabled. Adjusting the memory size depending on relocation and shadowing next.
58h	The memory size was adjusting for relocation and shadowing. Clearing the Hit message next.
59h	The Hit message is cleared. The AIT... message is displayed. Starting the DMA and interrupt controller test next.
60h	The DMA page register test passed. Performing the DMA Controller 1 base register test next.
62h	The DMA controller 1 base register test passed. Performing the DMA controller 2 base register test next.
65h	The DMA controller 2 base register test passed. Programming DMA controllers 1 and 2 next.
66h	Completed programming DMA controllers 1 and 2. Initializing the 8259 interrupt controller next.
67h	Completed 8259 interrupt controller initialization.
7Fh	Extended NMI source enabling is in progress.
80h	The keyboard test has started. Clearing the output buffer and checking for stuck keys. Issuing the keyboard reset command next.
81h	A keyboard reset error or stuck key was found. Issuing the keyboard controller interface test command next.
82h	The keyboard controller interface test completed. Writing the command byte and initializing the circular buffer next.
83h	The command byte was written and global data initialization has completed. Checking for a locked key next.
84h	Locked key checking is over. Checking for a memory size mismatch with CMOS RAM data next.
85h	The memory size check is done. Displaying a soft error and checking for a password or bypassing WINBIOS Setup next.
86h	The password was checked. Performing any required programming before WINBIOS Setup next.
87h	The programming before WINBIOS Setup has completed. Uncompressing the WINBIOS Setup code and executing the AMIBIOS Setup or WINBIOS Setup utility next.
88h	Returned from WINBIOS Setup and cleared the screen. Performing any necessary programming after WINBIOS Setup next.
89h	The programming after WINBIOS Setup has completed. Displaying the power on screen message next.
8Bh	The first screen message has been displayed. The AIT... message is displayed. Performing the PS/2 mouse check and extended BIOS data area allocation check next.
8Ch	Programming the WINBIOS Setup options next.
8Dh	The WINBIOS Setup options are programmed. Resetting the hard disk controller next.
8Fh	The hard disk controller has been reset. Configuring the floppy drive controller next.
95h	Initializing the bus option ROMs from C800 next.
96h	Initializing before passing control to the adapter ROM at C800.
97h	Initialization before the C800 adapter ROM gains control has completed. The adapter ROM check is next.
98h	The adapter ROM had control and has now returned control to BIOS POST. Performing any required processing after the option ROM returned control.
99h	Any initialization required after the option ROM test has completed. Configuring the timer data area and printer base address next.
9Ah	Set the timer and printer base addresses. Setting the RS-232 base address next.
9Bh	Returned after setting the RS-232 base address. Performing any required initialization before the Coprocessor test next.



9Ch	Required initialization before the Coprocessor test is over. Initializing the Coprocessor next.
9Dh	Coprocessor initialized. Performing any required initialization after the Coprocessor test next.
9Eh	Initialization after the Coprocessor test is complete. Checking the extended keyboard, keyboard ID, and Num Lock key next. Issuing the keyboard ID command next.
A2h	Displaying any soft errors next.
A3h	The soft error display has completed. Setting the keyboard typematic rate next.
A4h	The keyboard typematic rate is set. Programming the memory wait states next.
A5h	Memory wait state programming is over. Clearing the screen and enabling parity and the NMI next.
A7h	NMI and parity enabled. Performing any initialization required before passing control to the adapter ROM at E000 next.
A8h	Initialization before passing control to the adapter ROM at E000h completed. Passing control to the adapter ROM at E000h next.
A9h	Returned from adapter ROM at E000h control. Performing any initialization required after the E000h option ROM had control next.
AAh	Initialization after E000h option ROM control has completed. Displaying the system configuration next.
ABh	Uncompressing the DMI data and executing DMI POST initialization next.
B0h	The system configuration is displayed.
B1h	Copying any code to specific areas.
00h	Code copying to specific areas is done. Passing control to INT 19h boot loader next.

## To configure the motherboard jumpers and set up the BIOS

If the BIOS settings become corrupted, the Infinium oscilloscope PC motherboard will not recognize the hard drive and the unit will not boot. To determine the correct BIOS setup procedure for your configuration, determine the following information:

- BIOS release number
- RAM size shown on screen at power-up
- The type of floppy drive installed in your oscilloscope

The 1.44 MB floppy drive has the release button above the disk opening. The 120 MB floppy has the release button below the disk opening. From this information, determine the correct WINBIOS setup procedure in order to enter the correct BIOS settings.

When the motherboard is replaced, set the motherboard jumpers to support the CPU clock speed and CPU power. Refer to one of the following topics that applies to your Infinium later in this chapter for the correct jumper configuration procedure.

- Configuring the AMI Series 727 Motherboard
- Configuring the AMI Series 757 Motherboard for 200 CPU
- Configuring the AMI Series 757 Motherboard for 300 CPU
- Configuring the AMI Series 757 Motherboard for 300 CPU and 120 MByte Floppy Drive
- Configuring the FIC VA-503A Motherboard

### Motherboard / floppy drive configurations BIOS setup

**Configuration 1—Series 727 motherboard, 100 MHz CPU, and 1.44 Mbyte floppy drive** Infinium oscilloscopes, Agilent models 54810A/15A/20A/25A, with serial numbers US37349999 and below<sup>1</sup> came equipped with the AMI Series 727 motherboard and AMD K5-P133 (100 MHz) processors.

This motherboard lists the message "BIOS Release 727XXXXXX" when the BIOS setup is entered. See "To configure the AMI Series 727 WINBIOS Parameters" for the BIOS setup procedure. See "Configuring the AMI Series 727 Motherboard Jumpers" for motherboard jumper configuration to match the processor.

**Configuration 2—Series 757 motherboard, 200 MHz CPU, and 1.44 Mbyte floppy drive serial prefix range US3805 through US3838 with rear-panel label VIN # 020<sup>1</sup>** The second configuration Infiniums were equipped with AMI series 757 motherboards, AMD K6/200 (200 MHz) processors, and a 1.44 Mbyte floppy drive. The K6 processor is a dual-voltage processor with 2.9 V core and 3.3 V I/O. This dual-voltage processor requires that a 2.9 V voltage regulator module (VRM) is installed in the motherboard's VRM socket and that the J14 jumpers are set accordingly.

This motherboard lists the message "BIOS Release 757XXXXXX" and 16XXXXKB or 65XXXXKB of RAM when the BIOS setup is entered. See "To configure the AMI Series 757 WINBIOS Parameters with 1.44 Mbyte floppy drive" for the appropriate BIOS setup procedure. See "Configuring the AMI Series 757 Motherboard for 200 MHz CPU" for the motherboard jumper configuration to match the K6-200 processor.

**Configuration 3—Series 757 motherboard, 300 MHz CPU, and 1.44 Mbyte floppy drive serial prefix range US3845 through US3909 with rear-panel label VIN # 025<sup>1</sup>** Infinium oscilloscopes of configuration 3 were equipped with AMI Series 757 motherboards and the AMD K6/300 or K6-2/300 (300 MHz) processors. These K6 processors are dual-voltage processors with a 2.2 V core and 3.3 V I/O. These dual-voltage processors require a 2.2 V voltage regulator module (VRM) in the motherboard's VRM socket, and that the J14 jumpers are set accordingly.

---

1. If the PC motherboard was replaced with a newer type, please use the newer BIOS setup procedure that applies to that PC motherboard configuration.

This motherboard lists the message “BIOS Release 757XXXXXX” and 64XXXXKB of RAM when the BIOS setup is entered. See “To configure the AMI Series 757 WINBIOS Parameters with 1.44 Mbyte floppy drive” for the appropriate BIOS setup procedure. See “Configuring the AMI Series 757 Motherboard for 300 MHz CPU” for motherboard jumper configuration details to match the K6/300 or K6-2/300 processor.

**Configuration 4—Series 757 motherboard, 300 MHz CPU, and 120 Mbyte floppy drive serial prefix range US3919 through US3935 with rear-panel label VIN # 025**

Infinium oscilloscopes of this configuration were equipped with AMI Series 757 motherboards and the AMD K6/300 or K6-2/300 (300 MHz) processors. These K6 processors are dual-voltage processors with a 2.2 V core and 3.3 V I/O. These dual-voltage processors require a 2.2 V voltage regulator module (VRM) in the motherboard’s VRM socket, and that the J14 jumpers are set accordingly.

This motherboard lists the message “BIOS Release 757XXXXXX” and 64XXXXKB of RAM when the BIOS setup is entered. See “To configure the AMI Series 757 WINBIOS Parameters with 120 Mbyte floppy drive” for the appropriate BIOS setup procedure. See “Configuring the AMI Series 757 Motherboard for 300 MHz CPU” for jumper configuration details to match the K6/300 or K6-2/300 processor.

**Configuration 5—FIC Series VA-503A, 400 MHz CPU, and 120 MByte floppy drive serial prefix range US3949 and above with rear-panel label VIN # 03X<sup>2</sup>**

This configuration is labeled “VIN #030” on the instrument rear panel. Infinium oscilloscopes of this configuration are equipped with the FIC Series VA-503A motherboard and the AMD K6-2/400 processor. These processors are dual-voltage processors with a 2.2 V core and 3.3 V I/O. The motherboard’s voltage select switch S1 must be configured for the correct processor core voltage.

This motherboard configuration lists the following message or similar at turn-on:

```
Award Modular BIOS v.4.51PG - An Energy Star Friend
Copyright © 1984-99 Award Software
Version JN4202
AMD K6T-2/X00 CPU Found
Memory Test: 65536K OK
```

See “To Configure the FIC Series VA-503A Motherboard BIOS Parameters” for the appropriate BIOS setup procedure.

This configuration/vintage incorporates mechanical changes to the instrument chassis and cabling to match the change in form factor of this motherboard. See the Replaceable Parts chapter for new part numbers.

The respective motherboard jumper information and BIOS setups procedures are presented in the following pages.

**Agilent Technologies Service Note Describes Upgrade Details**



For improved performance and hard disk drive reliability, refer to Agilent Service Note 54810A-06. This service note gives detailed information for upgrading to 64 MB RAM, upgrading to revision 2.51 or newer code, and enabling power management in the BIOS. This combination of upgrades and power management settings enable the instrument to load the application into memory at power-up and allows the hard drive to power down. This provides for a quick response from the oscilloscope controls during use, while maximizing the hard drive life.

- 
- Option 8ZE, remanufactured unit, may be older an configuration than the serial prefix number indicates. In this case, refer to the rear-panel VIN # label, floppy drive, and BIOS screen to determine motherboard configuration.

**Configuring the AMI Series 727 Motherboard Jumpers**

There are several jumpers on the motherboard that must be configured to the correct settings for the AMD-K5-PR133 (100 MHz) microprocessor. Figure 5-9 shows the series 727 motherboard.

**Figure 5-9**

Pin 1 is identified by a square pin  and by a pointed box on the silkscreen. 

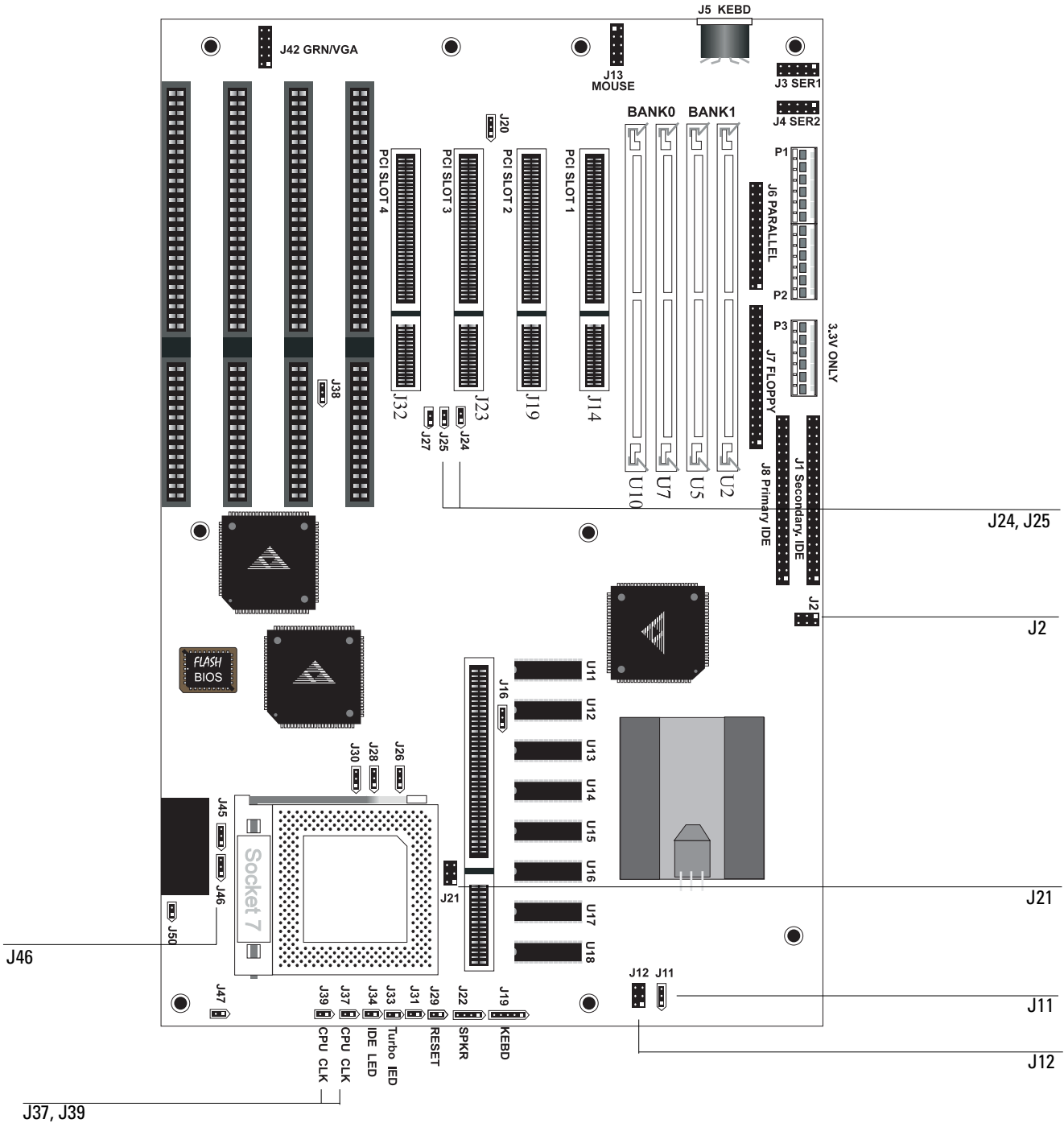

**Series 727 Motherboard Jumpers**

The jumpers you must check are J2, J11, J12, J21, J24, J25, J37, and J39. In addition, you need to ensure that the CPU fan is connected to J46 once the CPU is installed. Failure to connect the fan will cause the CPU to overheat and malfunction.

**CAUTION**

**AVOID DAMAGE TO THE CPU BY CORRECTLY CONFIGURING THE JUMPERS!**

You must configure J2, J11, J12, and J21 before installing the CPU and applying power to the motherboard. Failure to configure these jumpers correctly may damage the CPU.

- To configure the jumpers, set J2, J11, J12, and J21 as shown in the following figure. Note that all pairs of pins on J12 and J21 are shorted; all pins on J2 are open.

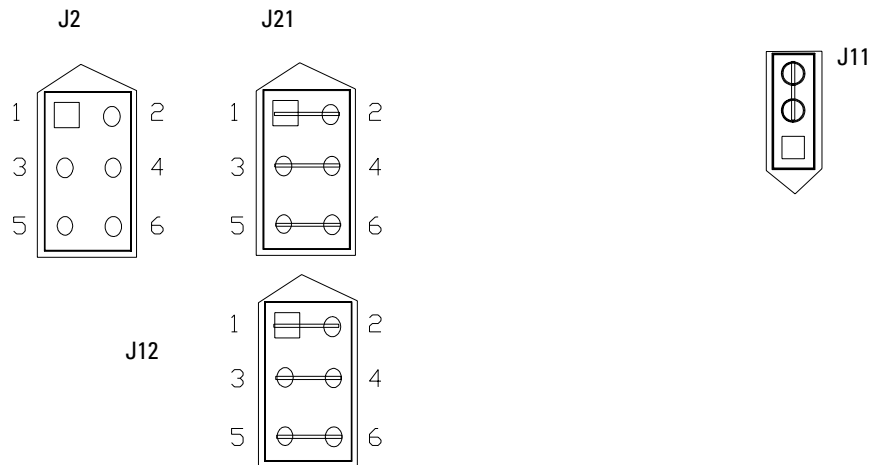

- The processor must be configured for a 100-MHz clock speed by setting jumpers J24, J25, J37, and J39 as shown in the following figure. Note that the pins on J25 are shorted and the pins on J24, J37, and J39 are open.

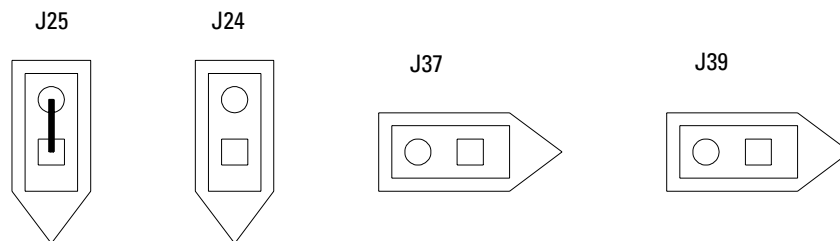

**A 100-MHz Clock Is Required**

The AMD-K5-PR133 processor requires a 100 MHz clock. The processor part number is printed on the top of the part.

- To connect the fan, connect the fan cable to J46. The colored fan lead must connect to Pin 1.

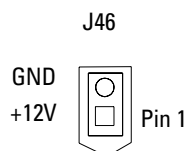

**To configure the motherboard jumpers and set up the BIOS****To configure the AMI Series 727 WINBIOS Parameters**

Use this procedure to set the motherboard system setup parameters, also known as the WINBIOS setup.

- 1 Connect the power cable to the oscilloscope.
- 2 Connect an external VGA monitor to the rear panel connector of the oscilloscope.
- 3 Connect an external keyboard and a mouse to the oscilloscope.
- 4 Hold down the Insert key on the external keyboard, then power-on the oscilloscope. Continue to hold down the Insert key until information begins to appear on the external VGA monitor.
  - a You should hear a burst of clicks from the internal hard disk drive as it executes its internal self-tests.
  - b After approximately 10 seconds, the text on the external VGA monitor should read as follows:

```
BIOS Release 727XXXXXX
NVRAM Ignored
16000 KB OK
WAIT...
<INS> Pressed
RUN SETUP
Press F1 to Resume
```

**Messages Vary Slightly**

These messages may vary slightly depending on the motherboard version.

If you see the word “ERROR” in the last few lines, or the oscilloscope does not appear to be functioning, check the motherboard jumper settings and the ribbon cable connectors. Proceed to the Primary Trouble Isolation flowchart. Otherwise, continue with the next step.

**5 Press F1 to run the WINBIOS setup.**

During the setup program, you can control the cursor with the mouse. If the mouse does not appear to work, press the Esc key on the external keyboard to exit the setup program. Turn off the oscilloscope, and ensure that the mouse is properly connected to the rear panel connector. You may also need to remove the cover and ensure that the mouse connector is correctly connected to the motherboard by the via PS/2 Mouse Cable W22.

You can use the keyboard in the WINBIOS setup to perform various functions. Refer to this table:

**WINBIOS Keyboard Commands**

Keystroke	Action
<Tab>	Change or select a global field.
←, ↑, →, ↓	Change or select the current field.
<Enter>	Perform an operation in the current field.
+	Increment a value.
-	Decrement a value.
<Esc>	Abort any window function.
<PgUp>	Return to the previous page.
<PgDn>	Advance to the next page.
<Home>	Returns to the beginning of the text.
<End>	Advance to the end of the text.
<Ctrl><Alt><+>	Change to high speed.
<Ctrl><Alt><->	Change to low speed.

- 6 Do the following within the setup program:
  - a Double-click on Optimal Defaults. Click Yes in response to “Load Optimal Values?”
  - b Double-click on Peripheral Setup, then select OnBoard Primary/Secondary IDE. Select Primary, then exit Peripheral Setup by clicking on the box in the upper left corner.
  - c Double-click on Detect IDE Utility. The line labeled “Pri. Master” should contain numeric information indicating that it has found a hard drive. Exit this utility.  
 If a hard drive was not found, check Motherboard Hard Drive Cable W9 and SVGA to Hard Drive Cable W10. If the drive is still not found, replace the hard disk drive.
  - d Double-click on Standard Setup, then select Date/Time. Use the mouse to set the current month, day, year, and time. When you are finished, exit the Date/Time block.
  - e Under Standard Setup, select Floppy A. Select 1.44 MB 3-1/2. Exit the Floppy A block, then exit Standard Setup.
  - f Select Advanced Setup, then select System Keyboard. Select Absent (not installed).

**System Keyboard Absent**

This tells the computer not to check the keyboard during the power-on self test. The keyboard will still function after this.

- g Under Advanced Setup, scroll down the list to find and select External Cache. Select Disabled, then exit Advanced Setup.

**Do steps h-l ONLY if Your System has 64 Mb RAM**

Perform steps h through l only if your instrument has 64 Mb of RAM installed. If your instrument has less than 64 Mb of RAM, skip to step 7.

- h Double-click on Power Management.
- i Click Power Management/APM and select Enabled.
- j Click Hard Disk Power Down Mode and select Suspend.
- k Click Hard disk Time Out (Minute) and select 15 min.
- l Exit Power Management Setup.

Table 5-7 summarizes the settings for the system configuration.

**Table 5-7**

**Series 727 System Configuration Settings**

Configuration Item	Setting
Load Optimal Defaults	YES
Peripheral Setup (OnBoard Primary/Secondary IDE)	Primary
Detect IDE Utility (Hard drive Primary Master)	Data
Standard Setup—Date/Time	Enter current values
Standard Setup—Floppy Drive A	1.44 MB, 3-1/2
Advanced Setup—System Keyboard	Absent
Advanced Setup—External Cache	Disabled
Power Management/APM*	Enabled
Hard Disk Power Down Mode*	Suspend
Hard Disk Time Out (minute)*	15 min

\* These configurations are only for instruments with 64 Mb or more of RAM.

**7 Exit the Setup program, saving the changes you made.**

The oscilloscope should now reboot and come up with the scope display. If it does not, recheck your steps in the above procedure. If all the settings are correct, return to the Primary Troubleshooting Procedure.

**Configuring the AMI Series 757 Motherboard for 200 MHz CPU**

There are several jumpers on the motherboard that must be configured to the correct settings for the AMD-K6 200 MHz microprocessor. Figure 5-10 shows the series 757 motherboard.

Figure 5-10

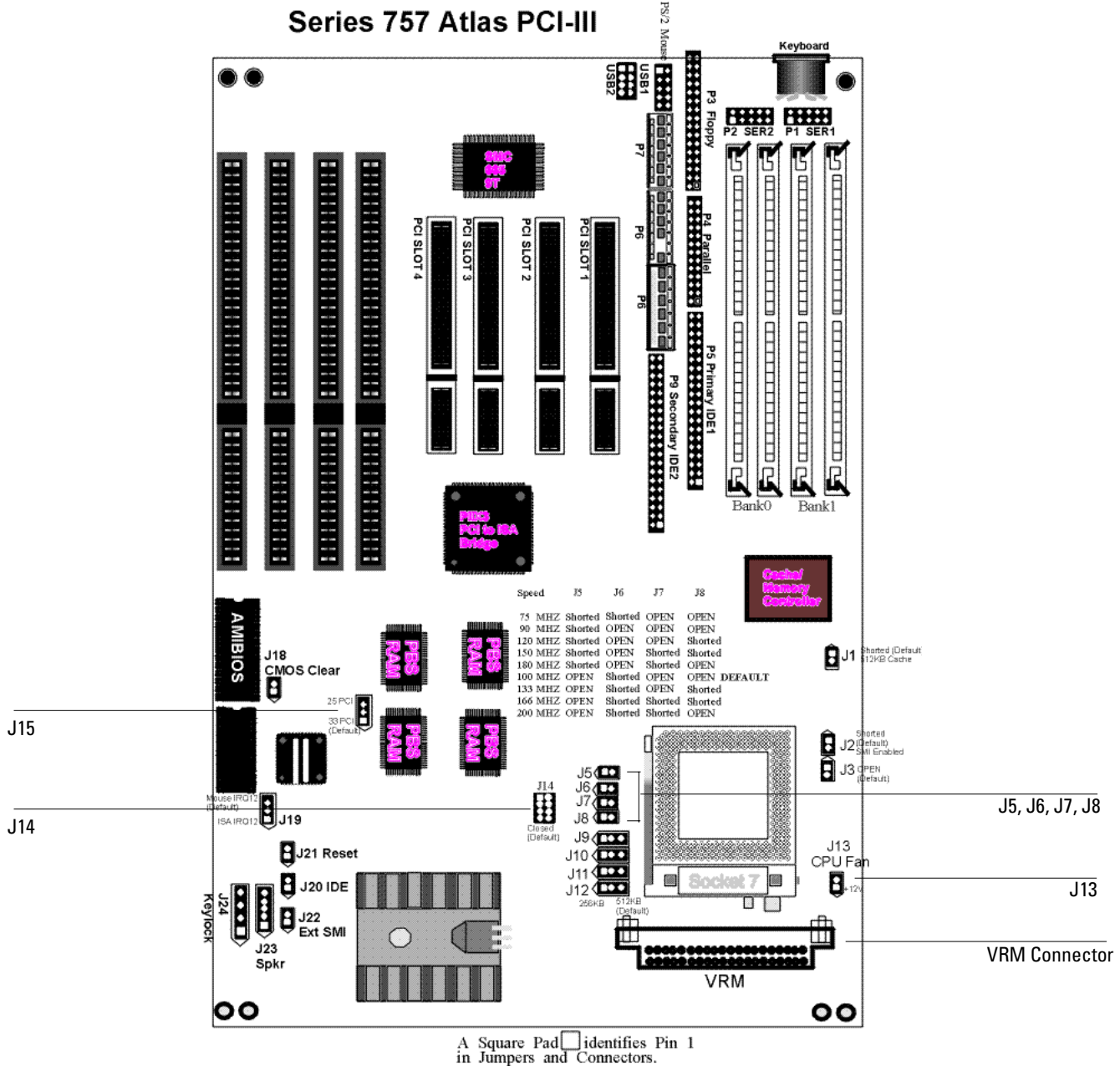

Series 757 Rev C Motherboard Jumpers



The jumpers you must check are J5, J6, J7, J8, J14 and J15. You must also install a 2.9 V VRM module in the VRM socket. In addition, you need to ensure that the CPU fan is connected to J13 once the CPU is installed. Failure to connect the fan will cause the CPU to overheat and malfunction.

---

**CAUTION**

---

**AVOID DAMAGE TO THE CPU BY CORRECTLY CONFIGURING THE JUMPERS!**

You must configure J5, J6, J7, J8, J14 and J15 before installing the CPU and applying power to the motherboard. Failure to configure these jumpers correctly may damage the CPU.

- To configure the jumpers, set J5, J6, J7, J8, and J14 as shown in the following figure. Note that the pairs of pins on J6 and J7 are shorted; the pairs of pins on J5 and J8 are open; and all pins on J14 are open.

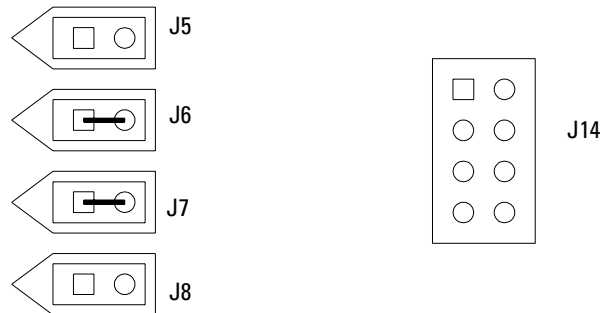

- The processor must be configured for a 66 (33) MHz PCI bus clock speed by shorting pins 1 and 2 on J15 as shown in the following figure.

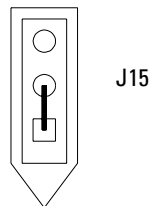

- Install a 2.9 V Voltage Regulator Module (VRM) in the VRM socket. Use Agilent part number 0950-2794 (VXI part number 073-20723-29 or Corsair part number SP5260TS-2X9).
- To connect the fan, connect the fan cable to J13. The colored fan lead must connect to Pin 1.

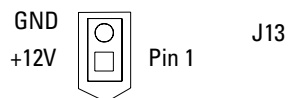

**To configure the AMI Series 757 WINBIOS Parameters with 1.44 Mbyte floppy drive**

Use this procedure to set the motherboard system setup parameters, also known as the WINBIOS setup.

- 1 Connect the power cable to the oscilloscope.
- 2 Connect an external VGA monitor to the rear panel connector of the oscilloscope.
- 3 Connect an external keyboard and a mouse to the oscilloscope.
- 4 Hold down the Insert key on the external keyboard, then power-on the oscilloscope. Continue to hold down the Insert key until information begins to appear on the external VGA monitor.
  - a You should hear a burst of clicks from the internal hard disk drive as it executes its internal self-tests.
  - b After approximately 10 seconds, the text on the external VGA monitor should read as shown below the caution.

---

**CAUTION**

---

DO NOT PRESS F2!

When the listing instructs you to “Press F2 to load default values and continue,”

DO NOT press F2 to load the default values since some units will not boot with default values.

```
AMI Atlas-III PCI/ISA
BIOS Release 757XXXXXX
AMD-K6(tm) - /200
Checking NVRAM
XX000 KB OK
```

```
WAIT...
```

```
<INS> Pressed
```

```
RUN SETUP
```

```
Press F1 to Run SETUP
```

```
Press F2 to load default values and continue
```

**Messages Vary Slightly**

These messages may vary slightly depending on the motherboard version.

If you see the word “ERROR” in the last few lines, or the oscilloscope does not appear to be functioning, check the motherboard jumper settings and the ribbon cable connectors. Proceed to the Primary Trouble Isolation flowchart. Otherwise, continue with the next step.

- 5 Press F1 to run the WINBIOS setup.

During the setup program, you can control the cursor with the mouse. If the mouse does not appear to work, press the Esc key on the external keyboard to exit the setup program. Turn off the oscilloscope, and ensure that the mouse is properly connected to the rear panel connector. You may also need to remove the cover and ensure that the mouse connector is correctly connected to the motherboard by the PS/2 Mouse Cable W22.

You can use the keyboard in the WINBIOS setup to perform various functions. Refer to this table:

**WINBIOS Keyboard Commands**

Keystroke	Action
<Tab>	Change or select a global field.
←, ↑, →, ↓	Change or select the current field.
<Enter>	Perform an operation in the current field.
+	Increment a value.
-	Decrement a value.
<Esc>	Abort any window function.
<PgUp>	Return to the previous page.
<PgDn>	Advance to the next page.
<Home>	Returns to the beginning of the text.
<End>	Advance to the end of the text.
<Ctrl><Alt><+>	Change to high speed.
<Ctrl><Alt><->	Change to low speed.

- 6** Do the following within the setup program:
  - a** Double-click on Optimal Defaults. Click Yes in response to “Load Optimal Values?”
  - b** Double-click on Standard Setup, then select Date/Time. Use the mouse to set the current month, day, year, and time. When finished, exit the Date/Time block.
  - c** Under Standard Setup, select Floppy A. Select 1.44 MB 3-1/2. Exit the Floppy A block.
  - d** Under Standard Setup, select Floppy B. Select Not Installed. Exit the Floppy B block, then exit Standard Setup.
  - e** Select Advanced Setup, then select System Keyboard. Select Absent (not installed).

**System Keyboard Absent**

This tells the computer not to check the keyboard during the power-on self test. The keyboard will still function after this.

- f** Exit the Advanced Setup.
- g** Double-click PCI/PnP Setup, then scroll down to select IRQ9. Select ISA, then exit PCI/PnP Setup.
- h** Double-click on Peripheral Setup, then select OnBoard Primary/Secondary IDE. Select Primary, then exit Peripheral Setup by clicking on the box in the upper left corner.

**When to Do this Procedure**

Perform steps i through m only if your instrument has 64 Mb of RAM installed. If your instrument has less than 64 Mb of RAM, skip to step n.

- i** Double-click on Power Management.
- j** Click Power Management/APM and select Enabled.
- k** Click Hard Disk Power Down Mode and select Suspend.
- l** Click Hard disk Time Out (Minute) and select 15 min.
- m** Exit Power Management Setup.
- n** Hold down the Insert key on the external keyboard while exiting the Setup program and save the changes you have made. Continue to hold the Insert key until the monitor shows the same information as in step 4.

**To configure the motherboard jumpers and set up the BIOS**

- 7** Re-enter the WINBIOS to change one parameter that could not be set in step 6.
- a** Press F1 to enter the BIOS Setup.
  - b** Double-click on Detect IDE Utility. The line labeled “Pri. Master” should contain numeric information indicating that it has found a hard drive. Exit this utility.  
If a hard drive was not found, check Motherboard Hard Drive Cable W9 and SVGA to Hard Drive Cable W10. If the drive is still not found, replace the hard disk drive.
  - c** Exit the BIOS Setup and save the changes you made.

Table 5-8 summarizes the settings for the system configuration.

**Table 5-8****Series 757 System BIOD Settings with 1.44 Mbyte floppy drive**

<b>Configuration Item</b>	<b>Setting</b>
Load Optimal Defaults	YES
Standard Setup—Date/Time	Enter current values
Standard Setup—Floppy Drive A	1.44 MB, 3-1/2
Standard Setup—Floppy Drive B	Not Installed
Advanced Setup—System Keyboard	Absent
PCI/PnP Setup—IRQ 9	ISA
Peripheral Setup (OnBoard Primary/Secondary IDE)	Primary
Detect IDE Utility (Hard drive Primary Master)	Data
Power Management/APM*	Enabled
Hard Disk Power Down Mode*	Suspend
Hard Disk Time Out (minute)*	15 min

\* These configurations are only for instruments with 64 Mb or more of RAM.

The oscilloscope should now reboot, load Windows 95, and come up with the scope display. If it does not, recheck your steps in the above procedure. If all the settings are correct, return to the Primary Troubleshooting Procedure.

**Configuring the AMI Series 757 Motherboard for 300 MHz CPU**

There are several jumpers on the motherboard that must be configured to the correct settings for the AMD-K6 300 MHz microprocessor. Figure 5-11 shows the series 757 Rev D motherboard.

**Figure 5-11**

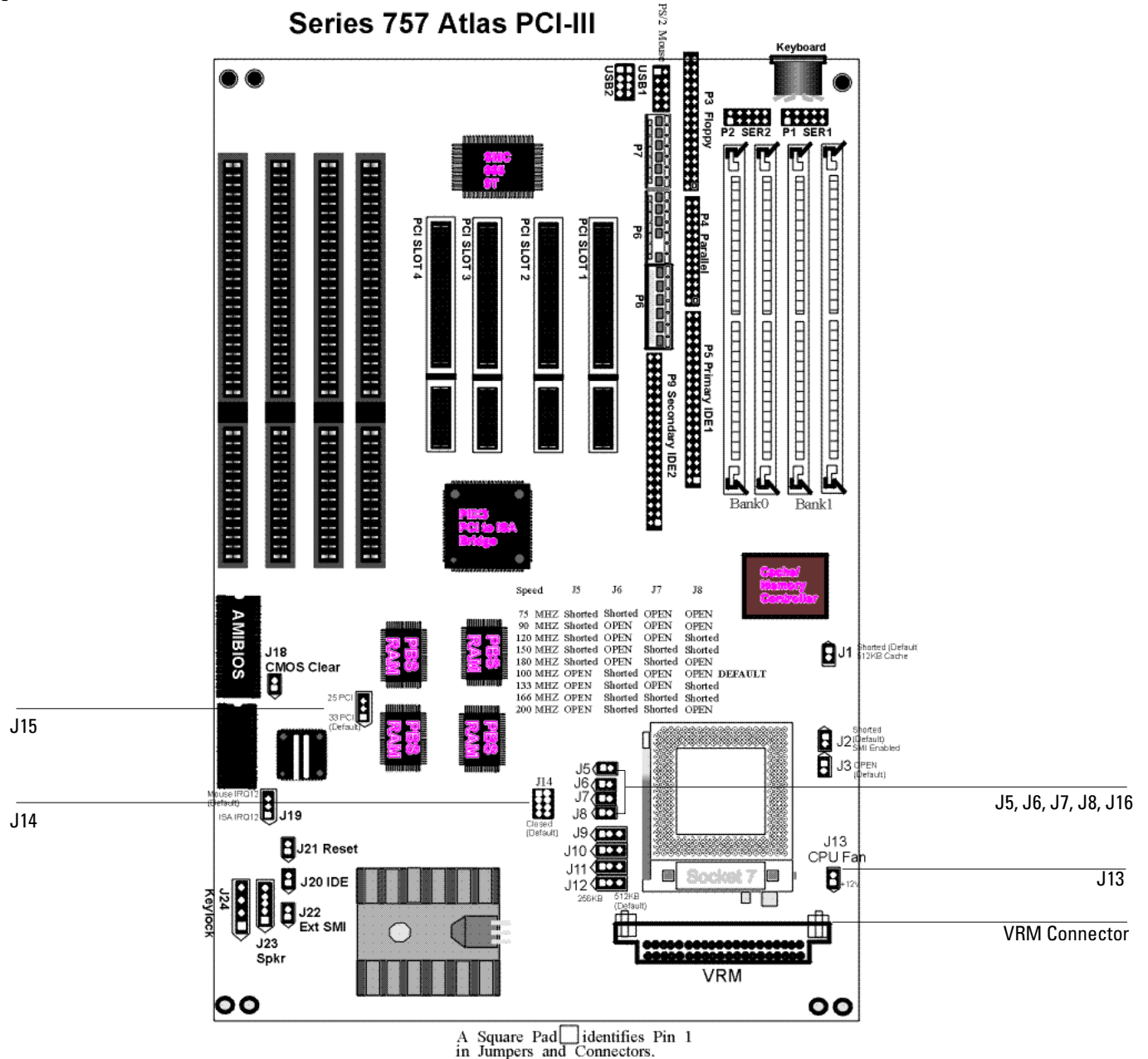

**Series 757 Rev D Motherboard Jumpers**

**To configure the motherboard jumpers and set up the BIOS**

The jumpers you must check are J5, J6, J7, J8, J14, J15 and J16. You must also install a 2.2 V VRM module in the VRM socket. In addition, you need to ensure that the CPU fan is connected to J13 once the CPU is installed. Failure to connect the fan will cause the CPU to overheat and malfunction.

**CAUTION**

**AVOID DAMAGE TO THE CPU BY CORRECTLY CONFIGURING THE JUMPERS!**

You must configure J5, J6, J7, J8, J14, J15 and J16 before installing the CPU and applying power to the motherboard. Failure to configure these jumpers correctly may damage the CPU.

- To configure the jumpers, set J5, J6, J7, J8, J14 and J16 as shown in the following figure. Note that the pairs of pins on J6, J7, J8 and J16 are shorted; the pairs of pins on J5 are open; and all pins on J14 are open.

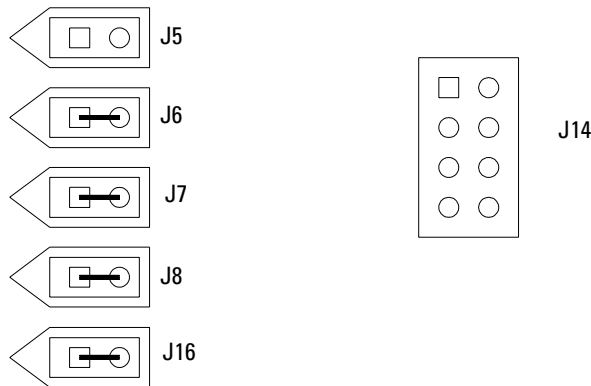

- The processor must be configured for a 66 (33) MHz PCI bus clock speed by shorting pins 1 and 2 on J15 as shown in the following figure.

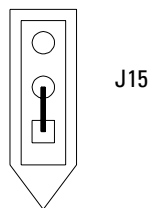

- Install a 2.2 V Voltage Regulator Module (VRM) in the VRM socket. Use Agilent part number 0950-3399 (VXI part number 073-20723-22).
- To connect the fan, connect the fan cable to J13. The colored fan lead must connect to Pin 1.

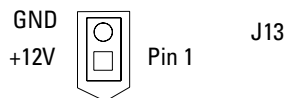

**To configure the AMI Series 757 WINBIOS Parameters with 120 Mbyte floppy drive**

Use this procedure to set the motherboard system setup parameters, also known as the WINBIOS setup.

- 1** Connect the power cable to the oscilloscope.
- 2** Connect an external VGA monitor to the rear panel connector of the oscilloscope.
- 3** Connect an external keyboard and a mouse to the oscilloscope.
- 4** Hold down the Insert key on the external keyboard, then power-on the oscilloscope. Continue to hold down the Insert key until information begins to appear on the external VGA monitor.
  - a** You should hear a burst of clicks from the internal hard disk drive as it executes its internal self-tests.
  - b** After approximately 10 seconds, the text on the external VGA monitor should read as shown:

---

**CAUTION**

---

DO NOT PRESS F2!  
When the listing instructs you to “Press F2 to load default values and continue”,  
DO NOT press F2 to load the default values since some units will not boot with default values.

```
AMI Atlas-III PCI/ISA
BIOS Release 757XXXXXX
AMD-K6 (tm) -/300
Checking NVRAM
65536 KB OK
```

```
WAIT...
```

```
<INS> Pressed
```

```
RUN SETUP
Press F1 to Run SETUP
Press F2 to load default values and continue
```

**Messages Vary Slightly**

These messages may vary slightly depending on the motherboard version.

If you see the word “ERROR” in the last few lines, or the oscilloscope does not appear to be functioning, check the motherboard jumper settings and the ribbon cable connectors. Proceed to the Primary Trouble Isolation flowchart. Otherwise, continue with the next step.

- 5** Press F1 to run the WINBIOS setup.

During the setup program, you can control the cursor with the mouse. If the mouse does not appear to work, press the Esc key on the external keyboard to exit the setup program. Turn off the oscilloscope, and ensure that the mouse is properly connected to the rear panel connector. You may also need to remove the cover and ensure that the mouse connector is correctly connected to the motherboard by the PS/2 Mouse Cable W22.

You can use the keyboard in the WINBIOS setup to perform various functions. Refer to this table:

---

**WINBIOS Keyboard Commands**

---

Keystroke	Action
<Tab>	Change or select a global field.
←, ↑, →, ↓	Change or select the current field.
<Enter>	Perform an operation in the current field.
+	Increment a value.
-	Decrement a value.
<Esc>	Abort any window function.
<PgUp>	Return to the previous page.
<PgDn>	Advance to the next page.
<Home>	Returns to the beginning of the text.
<End>	Advance to the end of the text.
<Ctrl><Alt><+>	Change to high speed.
<Ctrl><Alt><->	Change to low speed.

**6** Do the following within the setup program:

- a** Double-click on Optimal Defaults. Click Yes in response to “Load Optimal Values?”
- b** Double-click on Standard Setup, then select Date/Time. Use the mouse to set the current month, day, year, and time. When finished, exit the Date/Time block.
- c** Under Standard Setup, select Floppy A. Select Not Installed. Exit the Floppy A block.
- d** Under Standard Setup, select Floppy B. Select Not Installed. Exit the Floppy B block.
- e** Under Standard Setup, select Pri Slave, select Type and change to Floptical. Exit the Primary Slave Hard Disk, then exit Standard Setup.
- f** Select Advanced Setup, then select System Keyboard. Select Absent (not installed).

**System Keyboard Absent**

This tells the computer not to check the keyboard during the power-on self test. The keyboard will still function after this.

- g** Under Advanced Setup, scroll down to 1st Boot Device and select Floptical.
- h** Under Advanced Setup, select 2nd Boot Device and select IDE-0.
- i** Exit the Advanced Setup.
- j** Double-click PPCI/PnP Setup, then scroll down to select IRQ9. Select ISA, then exit PCI/PnP Setup.
- k** Double-click on Peripheral Setup, then select OnBoard Primary/Secondary IDE. Select Primary, then exit Peripheral Setup by clicking on the box in the upper left corner.
- l** Double-click on Power Management.
- m** Click Power Management/APM and select Enabled.
- n** Click Hard Disk Power Down Mode and select Suspend.
- o** Click Hard Disk Time Out (Minute) and select 15 min.
- p** Exit Power Management Setup.
- q** Hold down the Insert key on the external keyboard while exiting the Setup program and save the changes you have made. Continue to hold the Insert key until the monitor shows the same information as in step 4.



- 7 Re-enter the WINBIOS to change one parameter that could not be set in step 6.
  - a Press F1 to enter the BIOS Setup.
  - b Double-click on Detect IDE Utility. The line labeled “Pri. Master” should contain numeric information indicating that it has found a hard drive. Exit this utility.  
 If a hard drive was not found, check Motherboard Hard Drive Cable W9 and SVGA to Hard Drive Cable W10. If the drive is still not found, replace the hard disk drive.
  - c Exit the BIOS Setup and save the changes you made.

Table 5-9 summarizes the settings for the system configuration.

**Table 5-9**

**Series 757 System BIOS Settings with 120 Mbyte floppy drive**

<b>Configuration Item</b>	<b>Setting</b>
Load Optimal Defaults	YES
Standard Setup—Date/Time	Enter current values
Standard Setup—Floppy Drive A	Not Installed
Standard Setup—Floppy Drive B	Not Installed
Standard Setup—Pri Slave	Floptical
Advanced Setup—System Keyboard	Absent
Advanced Setup—1st Boot Device	Floptical
Advanced Setup—2nd Boot Device	IDE-0
PCI/PnP Setup—IRQ 9	ISA
Peripheral Setup (OnBoard Primary/Secondary IDE)	Primary
Power Management/APM	Enabled
Hard Disk Power Down Mode	Suspend
Hard Disk Time Out (minute)	15 min
Detect IDE Utility (Hard drive Primary Master)	Data

The oscilloscope should now reboot, load Windows 95, and come up with the scope display. If it does not, recheck your steps in the above procedure. If all the settings are correct, return to the Primary Troubleshooting Procedure.

**Configuring the FIC VA-503A motherboard switches for the 400 MHz CPU and 120 Mbyte floppy drive**

There are switches and a jumper on the FIC VA-503A motherboard that must be configured to the correct settings for the AMD K6-2/400 MHz microprocessor. The FIC VA-503A motherboard is shown in the following figure.

Figure 5-12

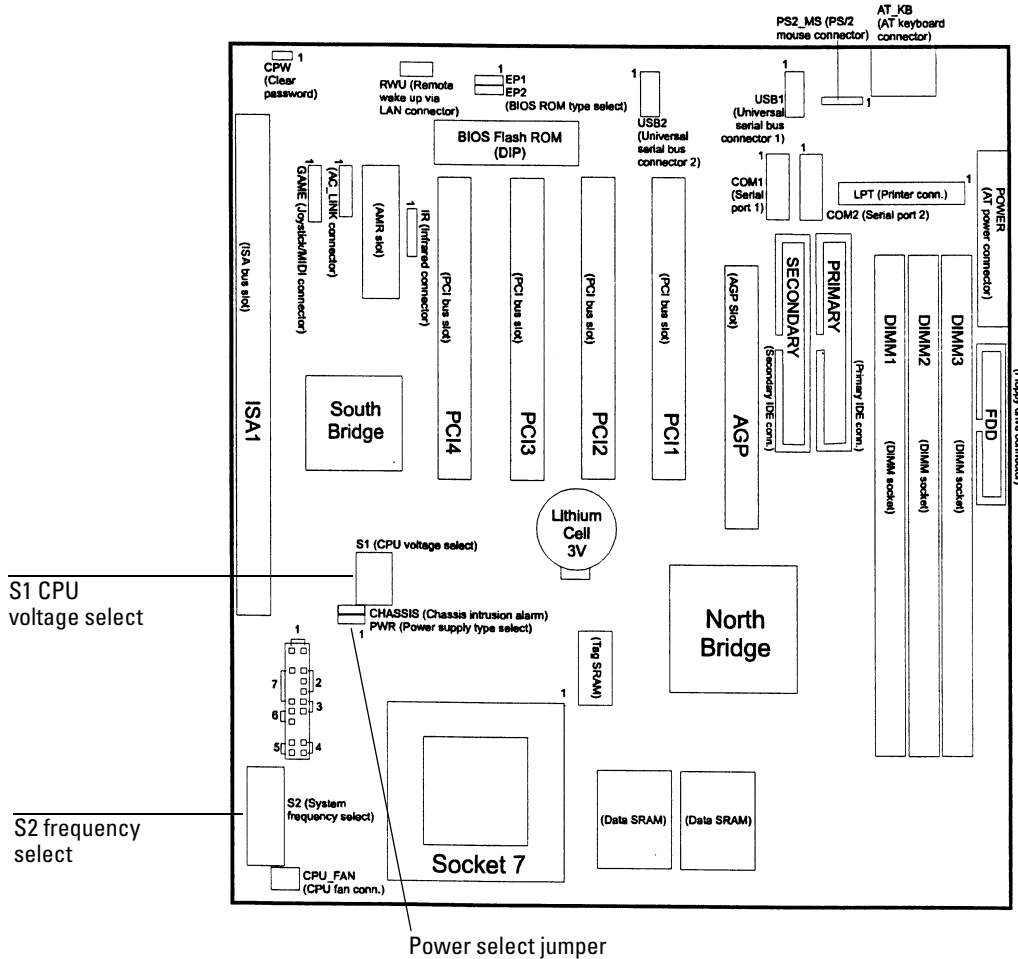

**FIC VA-503A Motherboard**

The dip switches and jumper are set as follows for the AMD K6-2/400 MHz processors:

- 1 Set the PWR (Power supply type select) jumper to 1-2.
- 2 Set S1 (CPU voltage select) for CPU core voltage; see core voltage on processor top.

2.2 V Core	S1-1	S1-2	S1-3	S1-4	S1-5
	Off	Off	Off	Off	On

S2 (System Frequency select) Switches S2-1 through S2-3 set the ratio of CPU Frequency/Bus Frequency. This is set to 4X for the K6-2/400 MHz processor.

Ratio	S2-1	S2-2	S2-3
K6-2/400 (4X)	Off	On	On

S2 (System Frequency select) Switches S2-4 through S2-10 are set to correspond to the CPU/SDRAM/PCI/AGP frequency.

S2-4	S2-5	S2-6	S2-7	S2-8	S2-9	S2-10
Off	Off	Off	On	Off	On	On

### To Configure the FIC Series VA-503A Motherboard BIOS Parameters

Use this procedure to set the FIC VA-503A motherboard BIOS.

- 1 Connect the power cable to the Infinium oscilloscope.
- 2 Connect the mouse to the rear panel of the oscilloscope.
- 3 Connect the external keyboard to the rear panel.
- 4 Power up the Infinium. A message similar to the following should appear on the screen.

```
Award Modular BIOS v.4.51PG - An Energy Star Friend
Copyright © 1984-99 Award Software
Version JN4104
AMD K6T-2/X00 CPU Found
Memory Test: 65536K OK
```

Press DEL to enter SETUP, ALT + F2 to enter AWDFLASH.

Note: If you see the word “ERROR” in the last few lines, or the oscilloscope does not appear to be functioning, check the motherboard jumper, switch settings, and the ribbon cable connectors. Otherwise, continue with the next step.

- 5 Press Delete when prompted by the message above to enter the BIOS setup menu.
- 6 Using the keyboard down arrow, key down to LOAD SETUP DEFAULTS and type “Y” to load the setup defaults.
- 7 Go to the standard CMOS setup and verify or change these settings:

- |   |                       |                   |
|---|-----------------------|-------------------|
| a | Set Date and Time     |                   |
| b | Primary Master Type   | Auto              |
| c | Primary Master Mode   | Auto              |
| d | Primary Slave         | None              |
| e | Secondary Master      | None              |
| f | Secondary Slave       | None              |
| g | Drive A               | None              |
| h | Drive B               | None              |
| i | Floppy 3 Mode Support | Disabled          |
| j | Video                 | EGA/VGA           |
| k | Halt On               | All, But Keyboard |

When you are finished, press **Esc** to exit the menu.

- 8 Go to the BIOS Features Setup and verify or change these settings:

- |   |                        |          |
|---|------------------------|----------|
| a | Anti-Virus             | Disabled |
| b | Boot from LAN First    | Disabled |
| c | Boot Sequence          | LS/ZIP,C |
| d | Boot Up Floppy Seek    | Disabled |
| e | Boot Up Numlock Status | Off      |
| f | Cyrix 6x86/MII CPUID   | Disabled |

When you are finished, press **Esc** to exit the menu.

- 9 Go to the Chipset Features menu and change this setting:

- |   |              |          |
|---|--------------|----------|
| a | OnChip Modem | Disabled |
|---|--------------|----------|

- 10 Under the Power Management Setup, change these settings:

- |   |                |        |
|---|----------------|--------|
| a | Modem use IRQ  | NA     |
| b | HDD power down | 15 min |

**11** Under the PnP/PCI Configuration, change these settings:

- a** PnP OS Installed            Yes
- b** Resources Controlled By   Manual
- c** IRQ-9 assigned to            Legacy ISA

**12** Under Integrated Peripherals, change these settings:

- a** Onboard FDD Controller      Disabled
- b** Onchip IDE second channel   Disabled

When you are finished, press **Esc** to exit the menu.

**13** Press F10 to save and exit the setup. Type “Y” to save changes.

---

## To troubleshoot the acquisition system

This procedure will help you isolate problems to the assembly or firmware level when the built-in Self Test routine shows acquisition system failures. Using this procedure, you can determine whether one or more of the attenuator assemblies, one or more of the A/D hybrids, the Probe board, the acquisition interface assembly, or the entire acquisition assembly is at fault. If you cannot isolate the fault to attenuator(s) or A/D hybrid(s), you must replace the entire acquisition assembly, including the attenuators and hybrids.

A built-in counter keeps track of the number of times the attenuator contacts have been opened and closed. This is a direct indicator of the usage level of the attenuator and is useful for scheduling preventative maintenance. When you replace the acquisition assembly with a factory rebuilt exchange assembly, you must record the contact closure information for each channel, using the labels attached to each attenuator. If you later exchange the acquisition assembly, Agilent Technologies uses this information to determine when to replace the attenuators to insure quality of future exchange assemblies.

### Determining the Acquisition Contact Closure Count

- 1** Select Self Test from the Utilities menu.
- 2** Check the “Service Extensions” check box.
- 3** Select Attenuator Contacts from the Self Test drop down list box.
- 4** Click Start Test to run the test.

The accumulated contact closure information will be displayed on the screen for each channel. Write this information on the label attached to each attenuator before returning the failed acquisition assembly.

### Isolating Acquisition Problems

The Infiniium acquisition system has been designed to work with firmware self-test routines, which provide pass/fail indications for each subsystem. Use the Passed/FAILED information and the trouble isolation chart to determine the appropriate assemblies to replace.

To run a particular test for troubleshooting, do the following:

- 1** Select Self Test from the Utilities menu.
- 2** Check the “Service Extensions” check box.
- 3** Select the desired test from the Self Test drop-down list box.
- 4** Click Start Test to run the test.

Run the tests in the following order, as shown by the flowchart.

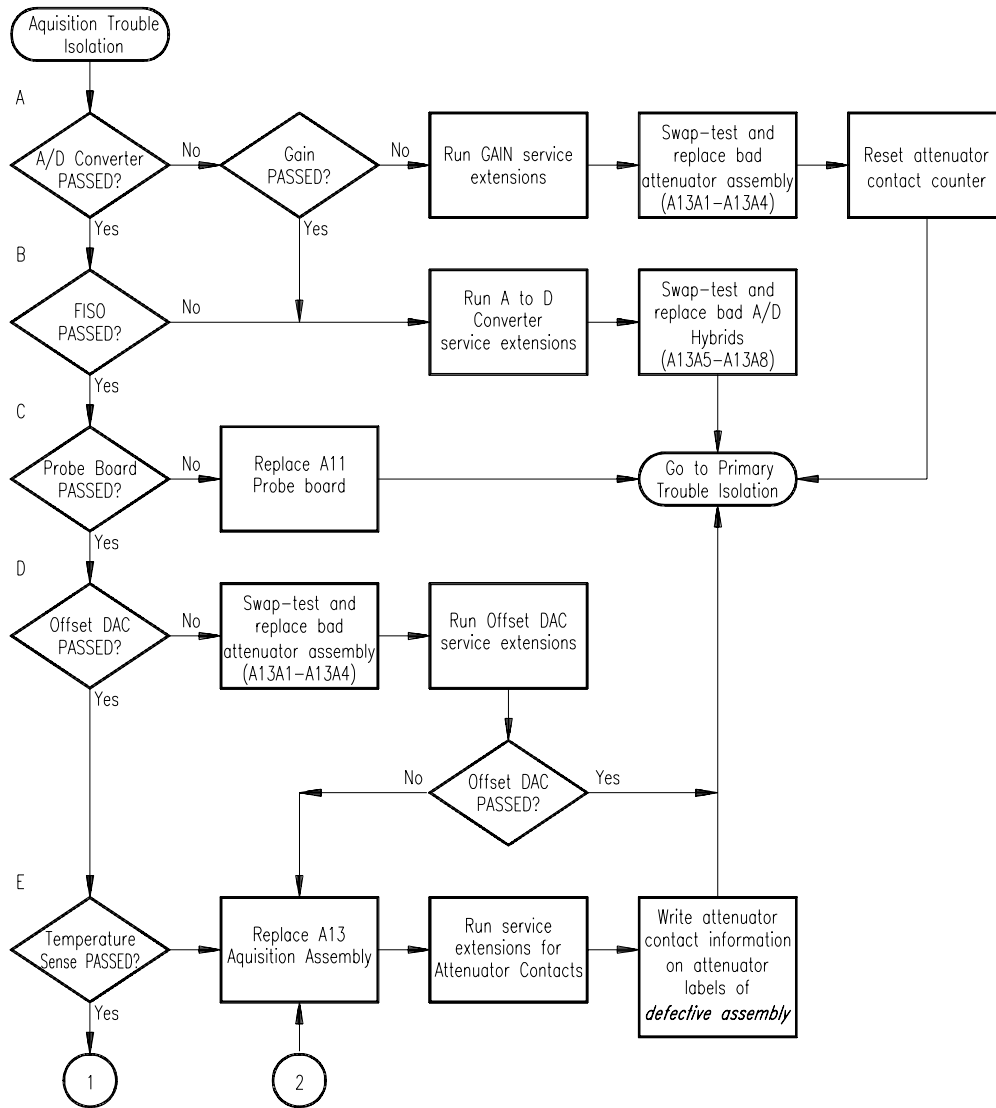

Acquisition Trouble Isolation (1 of 4)

Chapter 5: Troubleshooting  
To troubleshoot the acquisition system

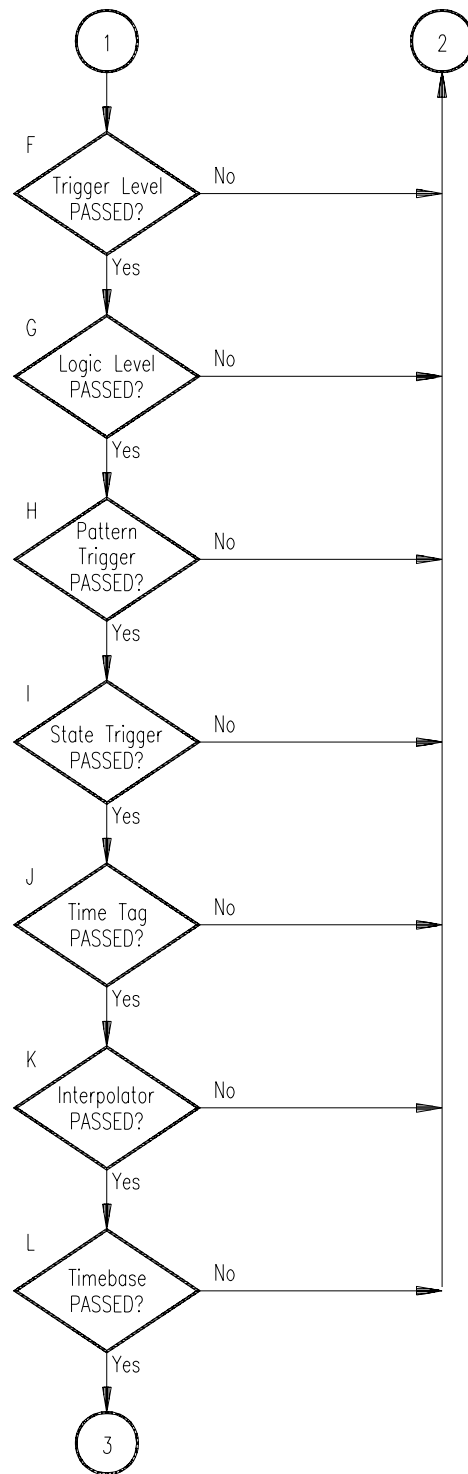

Acquisition Trouble Isolation (2 of 4)

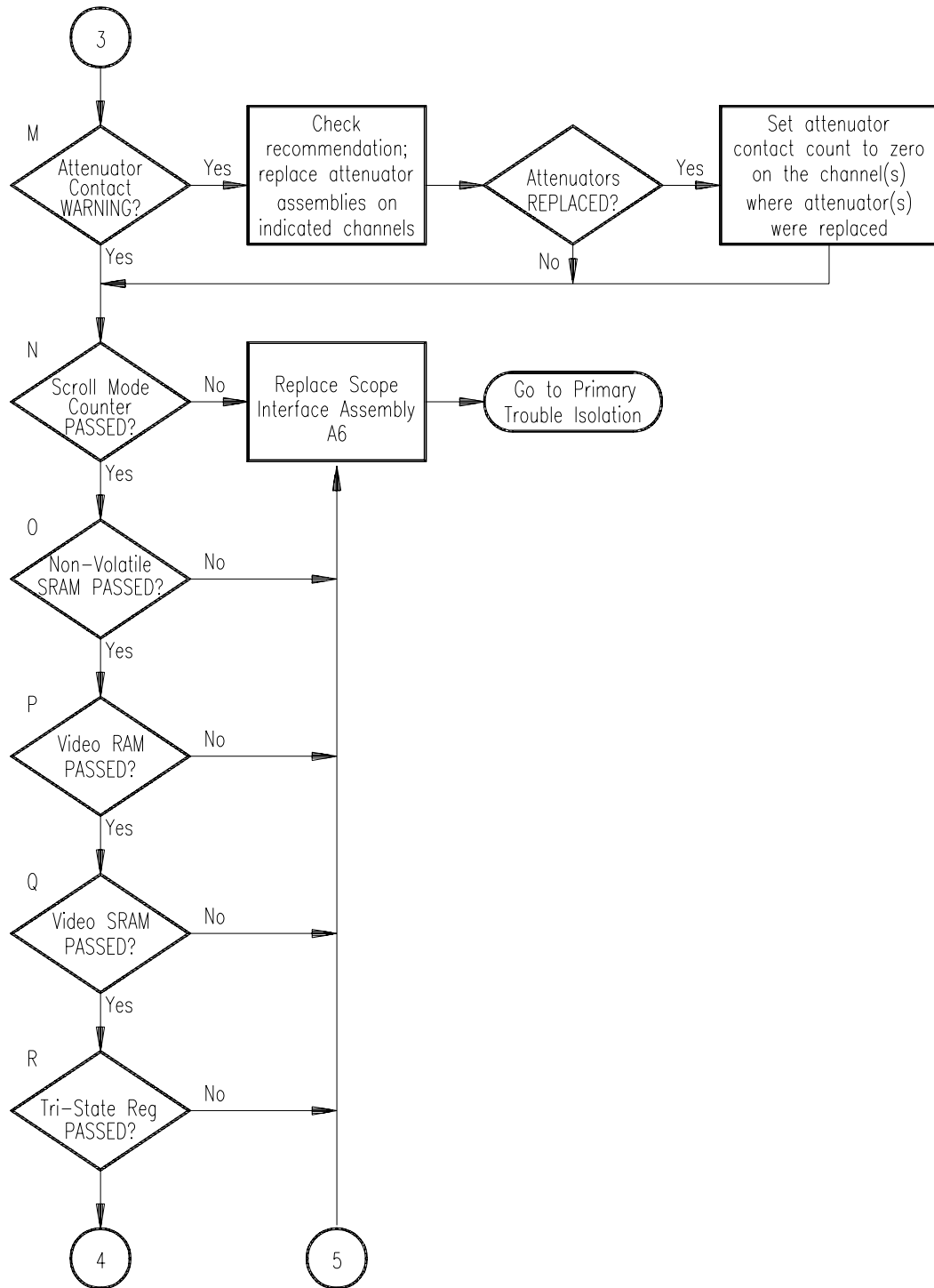

Acquisition Trouble Isolation (3 of 4)

Chapter 5: Troubleshooting  
To troubleshoot the acquisition system

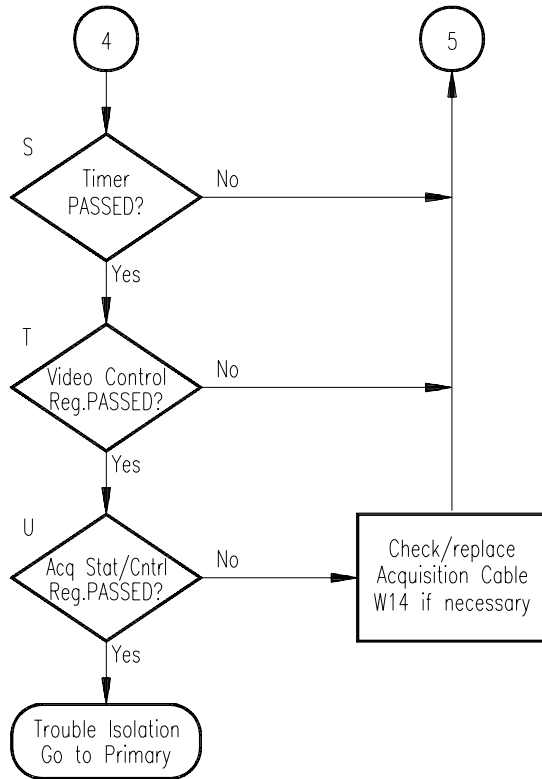

**Acquisition Trouble Isolation (4 of 4)**

**A A to D Converter Failed**

Failure of this test may involve failure in the Gain test. If the Gain test also fails, first attempt to correct the cause of the Gain test failure by running the Extended Service test for Gain. If any of the channels pass the extended service gain test, you can either use an attenuator from a known good channel to verify the problem in a failing channel, or simply replace the attenuator in a failing channel with a new one.

**Return the Known Good Attenuator to Original Channel**

If you swap attenuators to verify that the failure follows the attenuator assembly, return the known good attenuator to its original channel so that the attenuator contact counter is consistent with the specific attenuator.

When you replace one or more attenuators, you must reset the attenuator contact counter for the affected channel(s) to zero. This enables continued monitoring of the repaired channel.

If the Gain test passes, run the Extended Service test for the A to D Converter. If any of the channels pass the extended service A to D Converter test, you can swap an A to D hybrid from a known good channel to a suspected failing channel to verify the problem, or simply replace the failing A to D hybrid with a new hybrid.



**B FISO failed**

When this test fails, run the Extended Service test for the A to D Converter. If any of the channels pass the extended service A to D Converter test, you can swap an A to D hybrid from a known good channel to a suspected failing channel to verify the problem, or simply replace the failing A to D hybrid with a new hybrid.

**C Probe Board failed**

Replace the Probe Power and Control assembly.

**D Offset DAC failed**

Either an Attenuator Assembly failure or Acquisition Assembly failure can cause this test to fail. If the Offset DAC test fails, first attempt to correct the failure by swapping in known good attenuator assemblies and then running the Offset DAC Service Extension. If the Offset DAC test continues to fail, exchange the acquisition assembly, which includes attenuator assemblies. Before you replace the acquisition assembly with a factory rebuilt exchange assembly, record the contact closure information for each channel onto the labels attached to each attenuator. Agilent Technologies uses this to determine when to replace the attenuators to insure quality of future exchange assemblies.

**E Temperature Sense failed**

Replace the acquisition assembly when this test fails. Before you replace the acquisition assembly with a factory rebuilt exchange assembly, record the contact closure information for each channel onto the labels attached to each attenuator. Agilent Technologies uses this to determine when to replace the attenuators to insure quality of future exchange assemblies.

**F Trigger level failed**

Replace the acquisition assembly when this test fails. Before you replace the acquisition assembly with a factory rebuilt exchange assembly, record the contact closure information for each channel onto the labels attached to each attenuator. Agilent Technologies uses this to determine when to replace the attenuators to insure quality of future exchange assemblies.

**G Logic Level failed**

Replace the acquisition assembly when this test fails. Before you replace the acquisition assembly with a factory rebuilt exchange assembly, record the contact closure information for each channel onto the labels attached to each attenuator. Agilent Technologies uses this to determine when to replace the attenuators to insure quality of future exchange assemblies.

**H Pattern Trigger failed**

Replace the acquisition assembly when this test fails. Before you replace the acquisition assembly with a factory rebuilt exchange assembly, record the contact closure information for each channel onto the labels attached to each attenuator. Agilent Technologies uses this to determine when to replace the attenuators to insure quality of future exchange assemblies.

**I State Trigger failed**

Replace the acquisition assembly when this test fails. Before you replace the acquisition assembly with a factory rebuilt exchange assembly, record the contact closure information for each channel onto the labels attached to each attenuator. Agilent Technologies uses this to determine when to replace the attenuators to insure quality of future exchange assemblies.

**J Time Tag failed**

Replace the acquisition assembly when this test fails. Before you replace the acquisition assembly with a factory rebuilt exchange assembly, record the contact closure information for each channel onto the labels attached to each attenuator. Agilent Technologies uses this to determine when to replace the attenuators to insure quality of future exchange assemblies.

**K Interpolator failed**

Replace the acquisition assembly when this test fails. Before you replace the acquisition assembly with a factory rebuilt exchange assembly, record the contact closure information for each channel onto the labels attached to each attenuator. Agilent Technologies uses this to determine when to replace the attenuators to insure quality of future exchange assemblies.

**L Timebase failed**

Replace the acquisition assembly when this test fails. Before you replace the acquisition assembly with a factory rebuilt exchange assembly, record the contact closure information for each channel onto the labels attached to each attenuator. Agilent Technologies uses this to determine when to replace the attenuators to insure quality of future exchange assemblies.

**M Attenuator contact warning**

The oscilloscope software monitors closures for each set of attenuator contacts and accumulates the closure count. The set of contacts with the highest number of closures is the one reported for the channel. When the accumulation for any set of contacts for a channel reaches two million closures, this test displays a warning message. This warning is not an indication of attenuator failure. This warning does advise you that the attenuator is near the mean of its range of reliable usage. You should plan your maintenance strategy based on this contact closure information and your application. For example, in an automated test application, you might want to replace attenuators as soon as the warning appears; this will help prevent costly production line stops. In a bench test application, you might choose to take the warning as an advisory only, and continue to monitor the oscilloscope's measurement accuracy. You can then replace attenuators when measurement accuracy changes dramatically or when a failure occurs.

**N Scroll Mode Counter failed**

Replace the scope interface board.

**O Nonvolatile SRAM failed**

Replace the scope interface board.

**P Video RAM failed**

Replace the scope interface board.

**Q Video SRAM failed**

Replace the scope interface board.

**R Tri-State Register failed**

Replace the scope interface board.

**S Timer failed**

Replace the scope interface board.

**T Video Control Register failed**

Replace the scope interface board.

**U Test Acquisition State/Control Register failed**

Replace the scope interface board.

---

## To troubleshoot attenuator failures

The best method for troubleshooting attenuator failures is to swap the suspected one with a known good one. This discussion will help you determine whether the attenuator or acquisition board is causing a problem.

The attenuators consist of the following:

- A solenoid selected input resistance (50  $\Omega$  or 1 M $\Omega$ )
- Two solenoid selected passive attenuators (1:1/5:1 and 1:1/25:1) which can be cascaded to provide attenuation ranges of 1:1, 5:1, 25:1, 125:1
- An FET input circuit
- A programmable preamplifier

Defective attenuators can cause a variety of symptoms.

- Wrong input resistance
- Low bandwidth/slow rise time
- Signal distortion
- Calibration failures
- Self-test failures

The combination of attenuator and acquisition assembly affects the pulse response. You must check or adjust the pulse response after making any of the following changes.

- After installing a new attenuator. Adjust the channel with the new attenuator.
- After installing a new acquisition board. All channels must be adjusted.
- Permanently swapping attenuators, as when troubleshooting. Adjust the channels where the attenuators are permanently installed.

For pulse adjustment, of any affected channels, see “To adjust the high-frequency pulse response” in chapter 4, “Calibrating and Adjusting.”

Firmware Calibration should also be done after attenuator replacement (see chapter 4, “Calibrating and Adjusting”).

### Attenuator Click Test

The solenoids for the passive attenuators can be heard switching when the vertical sensitivity is changed. However, the gain calibration will give different switching points to different attenuator assemblies. Individual attenuator assemblies will not necessarily switch at the same sensitivities.

Check for switching sounds between the following range changes:

- 20 to 50 mV/div
- 200 to 500 mV/div
- 1.0 to 2.0 V/div

You can hear solenoid switching when going either direction through the transitions.

You can hear the input resistance solenoid when the input resistance is changed. Toggle the input resistance button for each channel.

If either of the click tests fail (solenoid or input resistance) the attenuator may be defective.

### Swapping Attenuators

Attenuator swapping is the best method of finding a faulty attenuator. All input channels of the Infiniium oscilloscope use identical attenuator assemblies. This troubleshooting method provides fast trouble isolation because it is unlikely that multiple channels will experience the same attenuator failure.

Swap suspected and good attenuators, and rerun the tests. The good attenuator can be a separate, known good part, or an attenuator from another channel of the oscilloscope. When you swap attenuators within the same oscilloscope, note the channel from which each attenuator was taken. If the swap test reveals a faulty attenuator, then install a new attenuator to replace the faulty one, and return the swapped attenuator to its original channel. Following this procedure will maintain the integrity of the attenuator actuation counter.

The attenuator actuation counter is maintained by the oscilloscope software to keep track of the number of times an individual attenuator has switched. Each attenuator is capable of 2 million or more actuations (switches of contacts) before the reliability of the contacts begins to degrade. This provides useful preventative maintenance information for keeping the Infiniium oscilloscope in peak measurement condition. If you replace or permanently swap an attenuator, you may need to reset the attenuator counter. See “To reset the attenuator contact counter” on page 6-29.

### Attenuator Connectivity Test

The attenuator scales incoming signals so that the acquisition system can accurately digitize the signal. The Attenuator Click Test verifies that the solenoids for switching input resistance and the passive attenuators are working. This connectivity test provides a qualitative assessment of attenuator operation.

- 1** Connect the Aux Out signal from the front panel to the Channel 1 input using a 50  $\Omega$  BNC cable.
- 2** Press the Default Setup key, then the Autoscale key.
- 3** The connected channel should display the 715 Hz square wave of the Aux Out signal. If the waveform is not found, or is not stable horizontally and vertically, the attenuator’s internal connectivity is suspect. Swap the attenuator with a new or known good attenuator (see “Attenuator Swapping”).
- 4** Repeat steps 1 through 3 for the remaining input channels.

If swapping attenuators into malfunctioning channels does not correct the problem, perform the procedure in “To run the self-calibration” in chapter 4. Then repeat the above procedure for the malfunctioning channels.

---

## Software Revisions

- Select About Infiniium... from the Help Menu.

**Enable the Graphical Interface**

The graphical interface must be enabled to select this command.

A dialog box appears showing the current version number for the scope software and on-line information system software. This information may be useful when contacting Agilent Technologies for further service information. See figure 5-13.

Figure 5-13

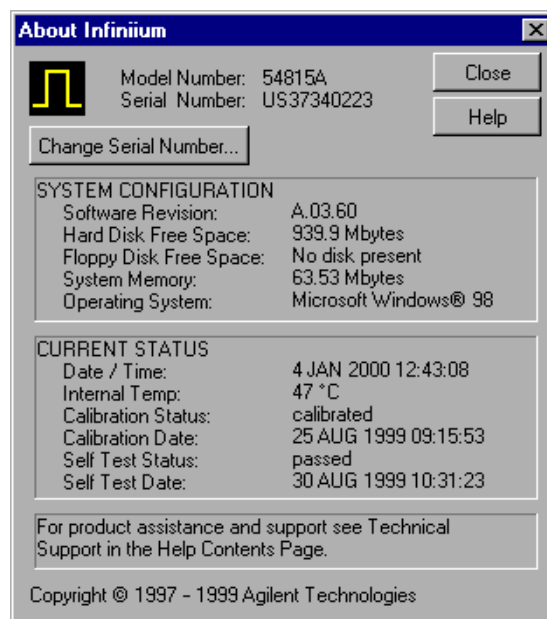

### About Infiniium... Information



- ESD Precautions 6-2
- Tools Required 6-2
- To return the instrument to Agilent Technologies for service 6-3
- To remove and replace the cover 6-4
- To disconnect and connect Mylar flex cables 6-5
- To remove and replace the AutoProbe assembly 6-6
- To remove and replace the probe power and control assembly 6-8
- To remove and replace the backlight inverter board 6-9
- To remove and replace the front panel assembly 6-9
- To remove and replace the keyboard, flat-panel display, and backlight assemblies 6-12
- To remove and replace the acquisition board assembly 6-14
- To remove and replace the LAN interface board 6-16
- To remove and replace the GPIB interface board 6-16
- To remove and replace the scope interface board and SVGA display board 6-17
- To separate the scope interface board and SVGA display board 6-18
- To remove and replace the Option 200 sound card 6-19
- To remove and replace the hard disk drive 6-20
- To remove and replace the floppy disk drive 6-21
- To remove and replace the motherboard 6-21
- To remove and replace the power supply 6-23
- To remove and replace the fan 6-24
- To remove and replace the CPU 6-25
- To remove and replace RAM SIMMs or SDRAM DIMMs 6-26
- To remove and replace an attenuator 6-27
- To reset the attenuator contact counter 6-29
- To remove and replace an acquisition hybrid 6-31

---

# Replacing Assemblies

Use the procedures in this chapter when removing and replacing assemblies and parts in the Agilent Technologies 54810A/15A/20A/25A oscilloscopes.

In general, the procedures that follow are placed in the order to be used to remove a particular assembly. The procedures listed first are for assemblies that must be removed first.

## ESD Precautions

When using any of the procedures in this chapter you must use proper ESD precautions. As a minimum you must place the instrument on a properly grounded ESD mat and wear a properly grounded ESD wrist strap.

---

### CAUTION

**AVOID DAMAGE TO THE INSTRUMENT!**

Failure to implement proper antistatic measures may result in damage to the instrument.

## Tools Required

The following tools are required for these procedures.

- Torx drivers: T8, T10, T15
- Socket wrench: 5/8 inch
- Medium size (3/16-in) flat-blade screwdriver
- Nut Drivers: 3/16-in, 9/32-in, 5/16-in, 5/8-in
- Torque driver, 0.34 Nm (3 in-lbs), 5 mm or 3/16-in hex drive
- Torque driver, 0.34 Nm (3 in-lbs), Torx T6 drive

---

### CAUTION

**REMOVE POWER BEFORE REMOVING OR REPLACING ASSEMBLIES!**

Do not remove or replace any circuit board assemblies in this instrument while power is applied. The assemblies contain components which may be damaged if the assembly is removed or replaced while power is connected to the instrument.

---

### WARNING

**SHOCK HAZARD!**

To avoid electrical shock, adhere closely to the following procedures. Also, after disconnecting the power cable, wait at least three minutes for the capacitors on the power supply and sweep boards to discharge before servicing this instrument. Hazardous voltages exist on the inverter for the display monitor.



## To return the instrument to Agilent Technologies for service

Before shipping the instrument to Agilent Technologies, contact your nearest Agilent Technologies Sales Office for additional details.

- 1 Write the following information on a tag and attach it to the instrument.**
  - Name and address of owner
  - Instrument model numbers
  - Instrument serial numbers
  - Description of the service required or failure indications
- 2 Remove all accessories from the instrument.**

Accessories include all cables. Do not include accessories unless they are associated with the failure symptoms.
- 3 Protect the instrument by wrapping it in plastic or heavy paper.**
- 4 Pack the instrument in foam or other shock absorbing material and place it in a strong shipping container.**

You can use the original shipping materials or order materials from an Agilent Technologies Sales Office. If neither are available, place 8 to 10 cm (3 to 4 inches) of shock-absorbing material around the instrument and place it in a box that does not allow movement during shipping.
- 5 Seal the shipping container securely.**
- 6 Mark the shipping container as FRAGILE.**

In any correspondence, refer to instrument by model number and full serial number.

---

## To remove and replace the cover

Use these to remove and replace the cover. When necessary, refer to other removal procedures.

- 1 Disconnect the power cable.
- 2 Disconnect all scope probes and BNC input cables from the front panel.
- 3 Disconnect any other cables, such as mouse, keyboard, printer, or GPIB cables.
- 4 Remove the two Torx T15 screws securing the side handle.
- 5 Remove the four Torx T15 screws that secure the rear feet (two in each foot).
- 6 Remove the four Torx T15 screws that secure the cover to the chassis.
- 7 Set the unit on its side. Carefully slide the cabinet off of the frame by pulling the front panel and the cover away from each other.
- 8 To replace the cover, reverse the above procedure.

Be sure to keep ribbon cables out of the way when replacing the cover, particularly the flex cable and connector for the AutoProbe assembly at the bottom front of the oscilloscope.

---

### CAUTION

PROPERLY TIGHTEN HANDLE AND SCREWS!  
Tighten the side handle and rear feet screws to 2 Nm (18 in-lbs).

---

Figure 6-1

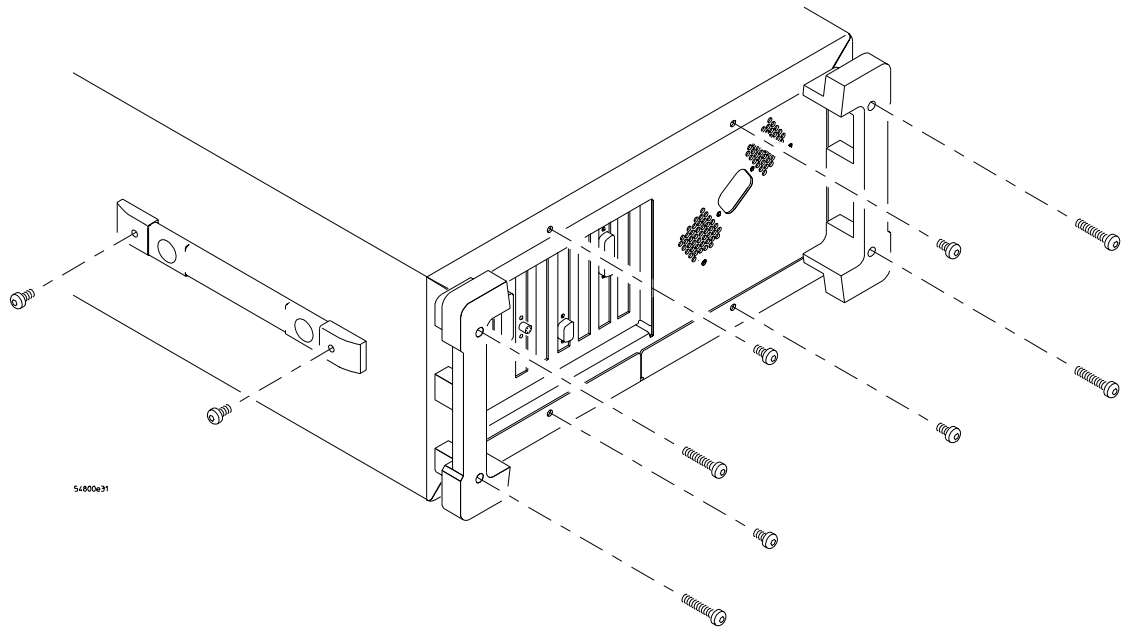

Cover Fasteners

---

## To disconnect and connect Mylar flex cables

Use this procedure when you are instructed to disconnect or connect a Mylar flex cable. Such cables and their connectors are fragile; mishandling may damage the cable or connector.

### To disconnect the cable

- 1 Pry up the retainer slightly at either end of the connector using a small flat-blade screwdriver. Do not force the retainer; it should remain attached to the body of the socket.
- 2 Gently pull the flex cable out of the connector.

Figure 6-2

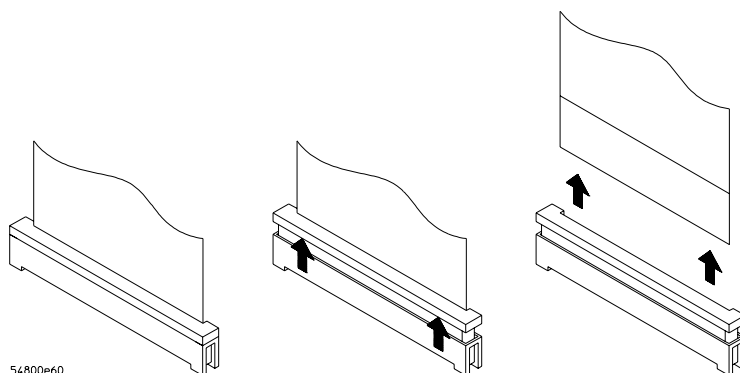

### Disconnecting a Mylar Ribbon Cable

### To reconnect the cable

- 1 Ensure that the cable retainer is up, then insert the ribbon cable into the socket, making sure to observe polarity of the cable with respect to the connector.
- 2 Push the ends of the retainer down onto the connector body, using a small flat-bladed screwdriver. The retainer should be flush with the connector body when you are finished.

Figure 6-3

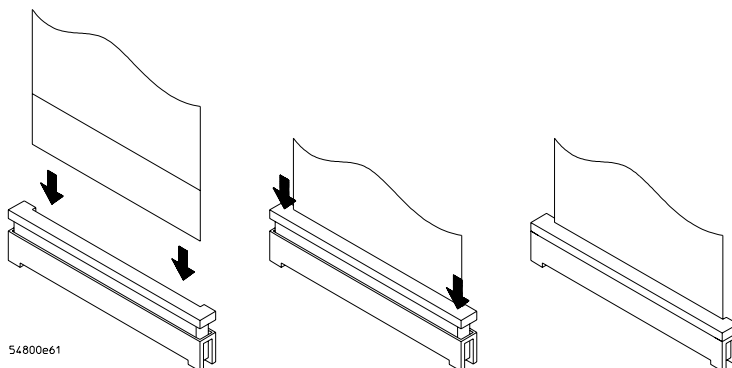

### Connecting Mylar Ribbon Cables

---

## To remove and replace the AutoProbe assembly

Use this procedure to remove and replace the AutoProbe assembly. When necessary, refer to other removal procedures.

- 1 Disconnect the power cable and remove the cover.
- 2 Remove the AutoProbe connector assembly, the subpanel, and the probe connector assembly that fits around the front-panel BNC connectors, by doing the following:
  - a Disconnect the Mylar ribbon cable W13 from the Probe Power and Control Board, A11.  
See “To disconnect and connect Mylar flex cables” in this chapter.

Figure 6-4

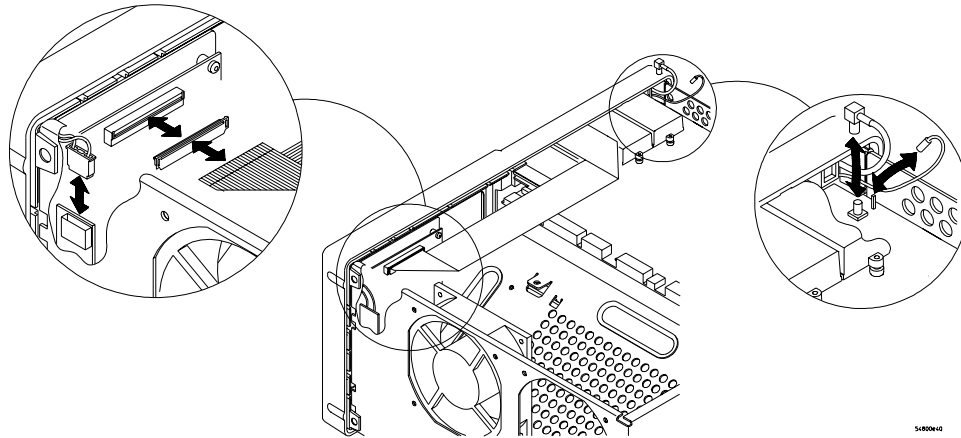

### Disconnecting W13

- b Locate the access hole in the front-panel assembly below and almost between channel two and channel three attenuators.

Figure 6-5

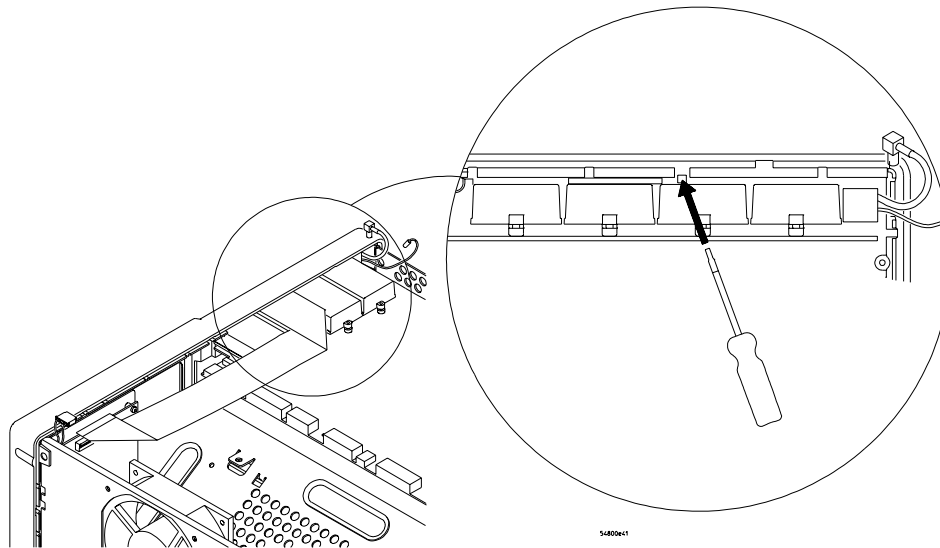

### Access Hole

- c From the back of the front panel, use a small screw driver or other slender pointed object through the access hole to push the AutoProbe assembly faceplate away from the front panel assembly.

Figure 6-6

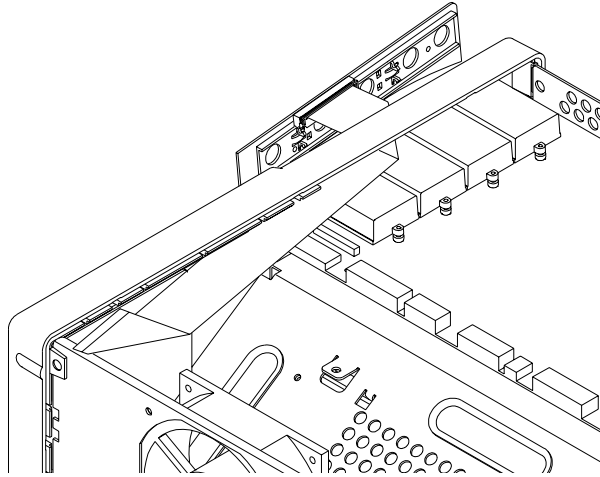

**Pushing Out the AutoProbe Faceplate**

---

**CAUTION**

---

AVOID DAMAGE TO THE RIBBON CABLE AND FACEPLATE!  
Do not pry around the edge of the assembly. Doing so may damage the ribbon cable or faceplate.

- d Finish removing the AutoProbe assembly by feeding the Mylar ribbon cable through the front panel slot.
- 3 To replace the AutoProbe assembly, reverse the above procedure.

---

## To remove and replace the probe power and control assembly

Use this procedure to remove the probe power and control assembly. When necessary, refer to other removal procedures.

- 1 Disconnect the power cable and remove the cover.
- 2 Disconnect the Mylar flex cable W13 that connects the probe power and control assembly to the AutoProbe assembly.  
The connector must be unlocked before you can remove the flex cable. See “To disconnect and connect Mylar flex cables” in this chapter.
- 3 Disconnect the Mylar flex cable W12 from the probe power and control assembly.
- 4 Remove the two Torx T10 screws securing the probe power and control assembly to the front panel chassis.

**Avoid Interference with the Fan**

You may need to use a Torx key or stubby Torx driver to avoid interference with the fan.

- 5 Lift the probe power and control assembly out and away from the chassis.
- 6 To replace the probe power and control assembly, reverse the above procedure.  
When inserting the assembly, be sure the two tabs on the circuit board engage the two slots in the sheet metal. Also, be sure to carefully lock in the connector for the Mylar flex cable when re-attaching the cable. See “To disconnect and connect Mylar flex cables” in this chapter.

Figure 6-7

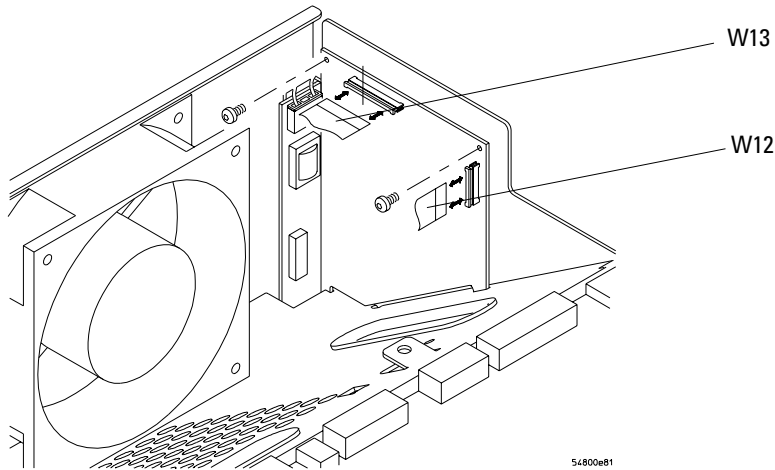

Removing the Probe Power and Control Assembly

---

## To remove and replace the backlight inverter board

Use this procedure to remove and replace the backlight inverter board. When necessary, refer to other removal procedures.

---

### WARNING

#### SHOCK HAZARD!

The backlight inverter assembly, which is mounted at the front corner of the instrument near the flat-panel display, operates at high voltages from 300-1 kV ac<sub>rms</sub>. DO NOT handle this assembly while it is in operation.

- 1 Disconnect the power cable and remove the cover.
- 2 Disconnect the two backlight cables from the top and bottom of the backlight inverter board.  
You can either stand the chassis on end or turn it over to gain access to both cables.
- 3 Disconnect the backlight primary cable W17 from the side of the backlight inverter board.
- 4 Remove the 2 Torx T10 screws that secure the backlight inverter board to the chassis.
- 5 Lift the backlight inverter board out through the top of the chassis.
- 6 To replace the backlight inverter board, reverse the assembly procedure.

Figure 6-8

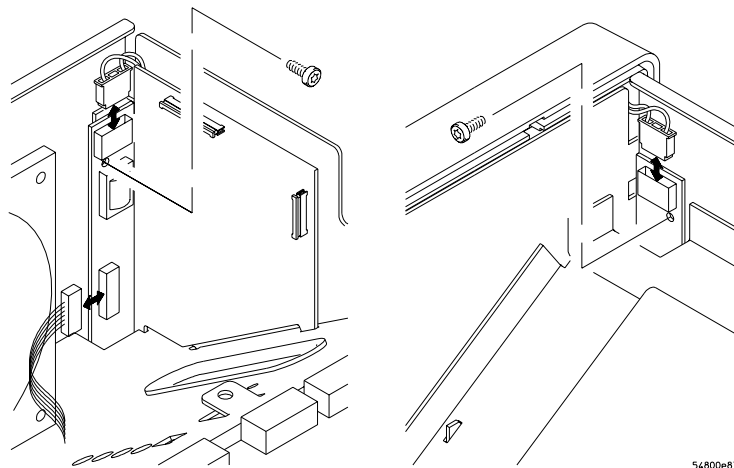

Removing the Backlight Inverter Board

---

## To remove and replace the front panel assembly

Use these steps to remove and replace the front panel assembly. When necessary, refer to other removal procedures.

- 1 Disconnect the power cable and remove the cover.
- 2 Remove the Quick-Probe assembly and Mylar flex cable W13.
- 3 Remove the hex nuts that secure the BNC connectors to the front panel.  
Use a 9/16" nut-driver to remove the hex nuts. There will be either three or five of these hex nuts, depending on the oscilloscope model.

Figure 6-9

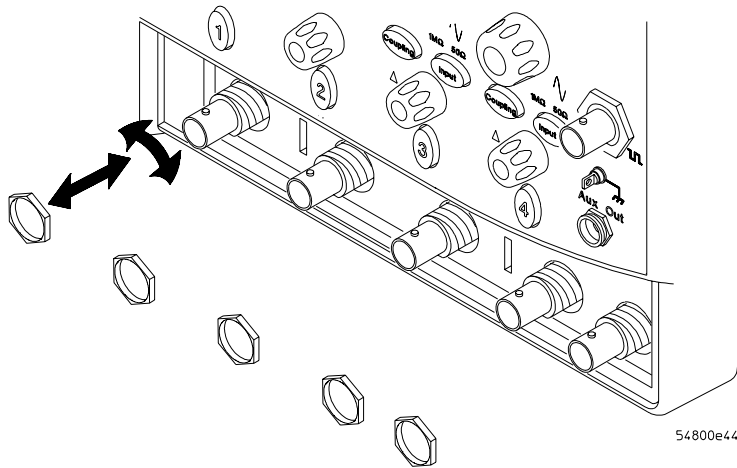

**Removing the BNC Nuts**

- 4 Disconnect the Aux Out SMB cable W18 from J2 and the black Comp wire W19 from J3. Push them to the side.  
These cables are located behind the Aux Trigger Input BNC connector on the Acquisition board.

Figure 6-10

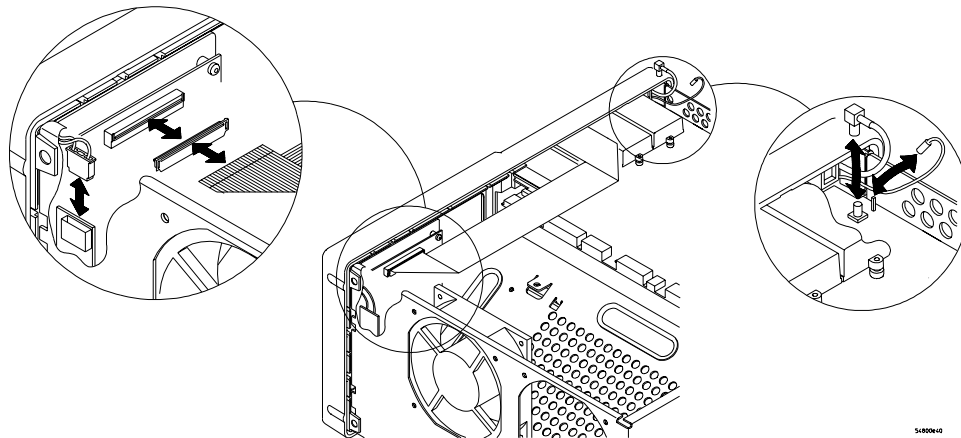

**SMB Cable W18 and Comp Wire W19**

- 5 Disconnect all the cables to the front panel assembly including the backlight cables, flat-panel display driver cable W20, and keyboard cable W16.



Figure 6-11

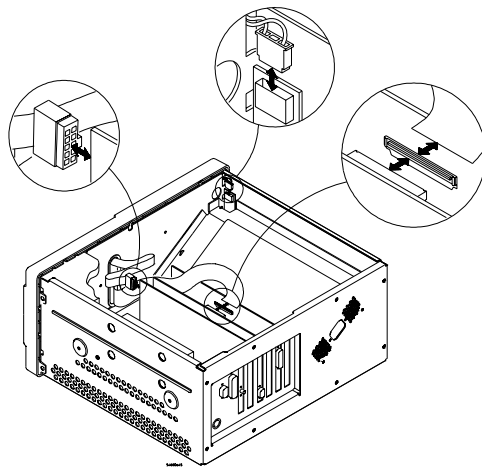

**Disconnecting W16, W20, and the Backlight Cables**

- 6 Remove the 4 Torx T15 screws that secure the chassis sides to the front panel assembly.

Figure 6-12

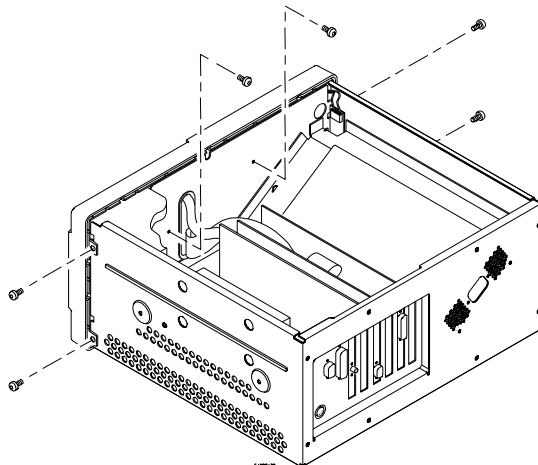

**Front Panel Side Screws**

- 7 Remove the 2 Torx T10 screws that secure the chassis front to the front panel assembly.
- 8 Pull the front panel assembly away from the chassis, being careful to feed the ribbon cables W16 and W20 out through the slot in the front of the chassis.
- 9 To replace the front panel assembly, reverse the above procedure.  
Ensure that you observe polarity designations when reconnecting the ribbon cables.

---

## To remove and replace the keyboard, flat-panel display, and backlight assemblies

Use these steps to disassemble and re-assemble the front panel assembly, including the keyboard and flat-panel display. Where necessary, refer to other removal procedures.

- 1 Disconnect the power cable and remove the cover.
- 2 Remove the front panel assembly from the chassis.
- 3 Remove the ten Torx T10 screws that secure the front panel cover plate to the front casting.

**Figure 6-13**

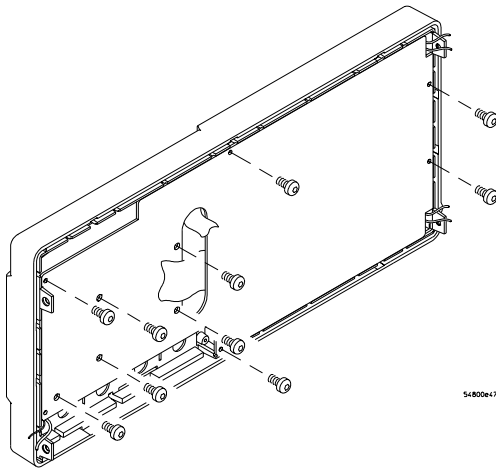

### Front Panel Cover Plate Screws

- 4 Carefully feed the front-panel keyboard cable W16 and the flat-panel display driver cable W20 through the cable access hole while separating the front panel cover plate from the front casting.
- 5 To remove the main keyboard, disconnect the cursor keyboard cable W15, pull off the knobs, and lift out the keyboard.

#### Keep Long Screws Separate for Re-assembly

The four screws that fasten the keyboard to the front panel plate are longer than those around the perimeter of the plate. Keep them separate for re-assembly.

- 6 To remove the flat-panel display from the front-panel cover plate, remove the four Torx fasteners.
- 7 To remove the cursor keyboard and flat lens, remove the four Torx T10 screws that secure the lens corners, then carefully remove the lens. You can lift the cursor keyboard directly out of the front casting.

Figure 6-14

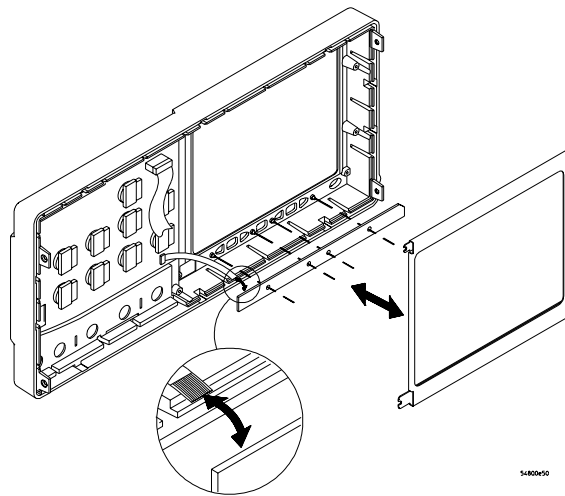

#### Removing the Cursor Keyboard

- 8 To remove the backlights, lift the tab and slide each backlight out of the flat-panel display.

Figure 6-15

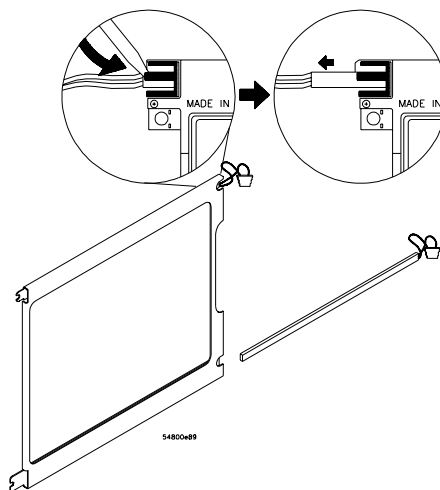

#### Removing the Backlights

- 9 To re-assemble the front panel assembly, reverse the above procedure.  
The cursor keyboard has holes that fit over locating pins in the front panel casting.

---

### CAUTION

---

#### PREVENT GLASS BREAKAGE!

Use care when handling the Lens Glass and the FPD monitor to prevent glass breakage.

Inspect the inside surfaces of the Lens Glass and the Display Monitor closely for dust, smudges, and finger prints. Viewing these with line-of-sight 45 degrees to the surface is the best method for seeing subtle faults. Clean the inside surfaces with glass cleaner and lint-free lens paper before re-assembly. Clean the front of the FPD monitor by applying the glass cleaner to the lint-free lens paper or soft lens cloth. Do not apply glass cleaner directly to the FPD monitor. This will prevent cleaner from corroding FPD connections.

## To remove and replace the acquisition board assembly

Use this procedure to remove and replace the acquisition assembly. When necessary, refer to other removal procedures.

- 1 Disconnect the power cable and remove the cover.**
- 2 Remove the Quick-Probe subpanel assembly.**
- 3 Remove the hex nuts that secure the BNC connectors to the front panel.**

Use a 9/16" nut-driver to remove the hex nuts. There will be either three or five of these hex nuts, depending on the oscilloscope model. See figure 6-9.
- 4 Disconnect the Aux Out SMB cable W18 from J2 and the black Comp wire W19 from J3 on the Acquisition assembly.**

These cables are located behind the Aux Trigger Input BNC connector. See figure 6-10.
- 5 Disconnect the following cables from the inside edge of the Acquisition assembly:**
  - Power supply control cable W2
  - Probe control cable W12
  - Auxiliary power supply cable W4
  - +5 V power supply cable W3
  - PC power cable W5
  - Line sync cable W6
  - Acquisition cable W11
  - Fan cable W21

These cables are attached to J4, J5, and J10 through J15.
- 6 Remove the 9 Torx T10 screws that secure the acquisition board to the chassis, then slide the board back from the front panel until the BNC connectors clear the panel. Lift the board away from the chassis.**
- 7 To re-install the acquisition board assembly, reverse the above procedure. Be sure to observe correct polarity for all cables.**

Figure 6-16

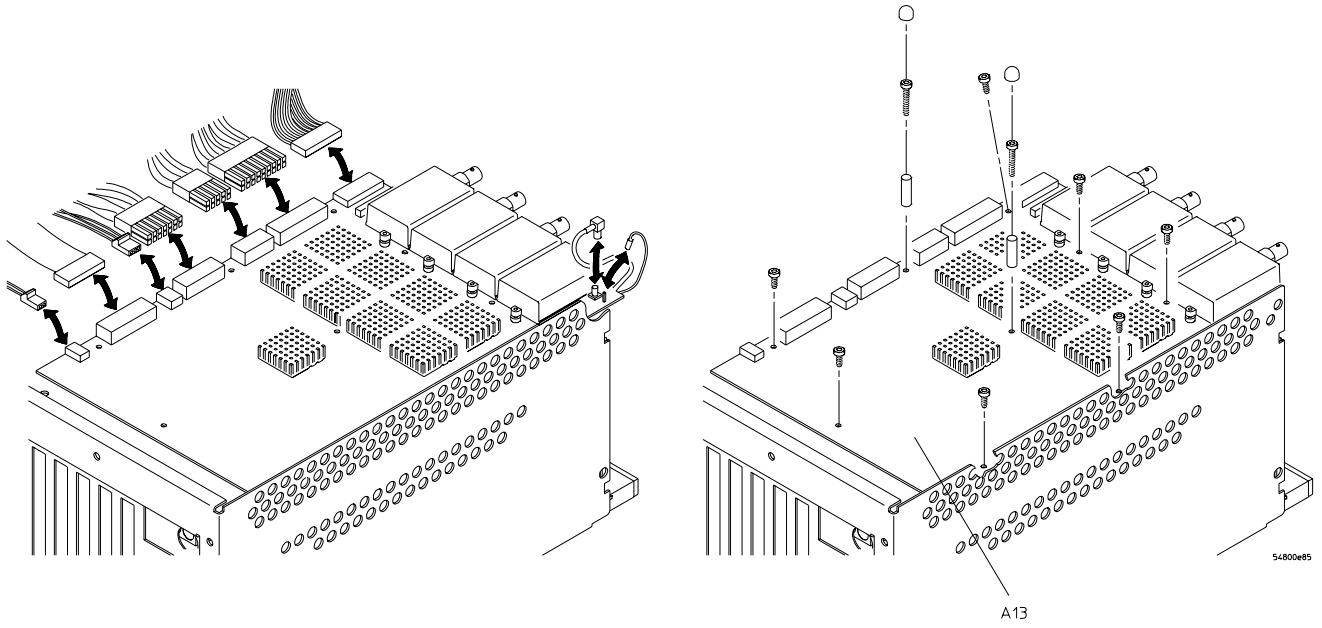

Removing the Acquisition Assembly

---

## To remove and replace the LAN interface board

Use this procedure to remove and replace the LAN interface board. When necessary, refer to other removal procedures.

- 1 Disconnect the power cable and remove the cover.
- 2 Remove the Torx T15 screw that secures the LAN board to the rear of the chassis.
- 3 Pull the board up to disengage it from the motherboard, then up and out of the chassis.

---

### CAUTION

BE CAREFUL TO NOT SNAG THE CABLE!  
Be careful not to snag the acquisition cable W11.

- 4 To replace the board, reverse the removal procedure.

Figure 6-17

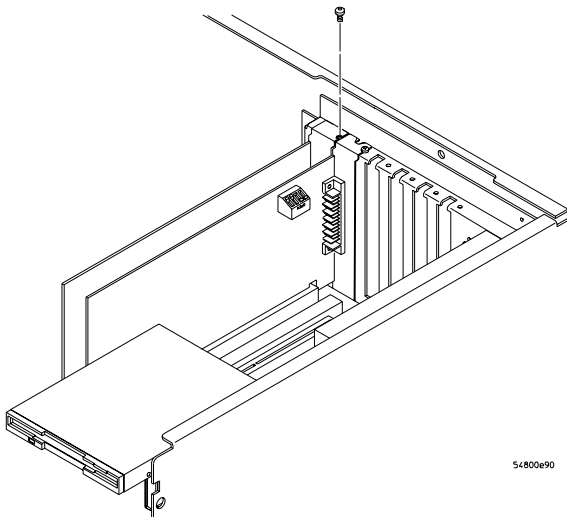

### Removing the LAN Interface Board

---

## To remove and replace the GPIB interface board

Use this procedure to remove and replace the GPIB interface board. When necessary, refer to other removal procedures.

- 1 Disconnect the power cable and remove the cover.
- 2 Remove the Torx T15 screw that secures the GPIB board to the rear of the chassis.
- 3 Pull the board up to disengage it from the motherboard, then up and out of the chassis.

---

### CAUTION

BE CAREFUL TO NOT SNAG THE CABLE!  
Be careful not to snag the acquisition cable W11.

- 4 To replace the board, reverse the removal procedure.

If you are replacing the board with a new one, ensure that the new board has the correct switch settings. See figure 6-18.

Figure 6-18

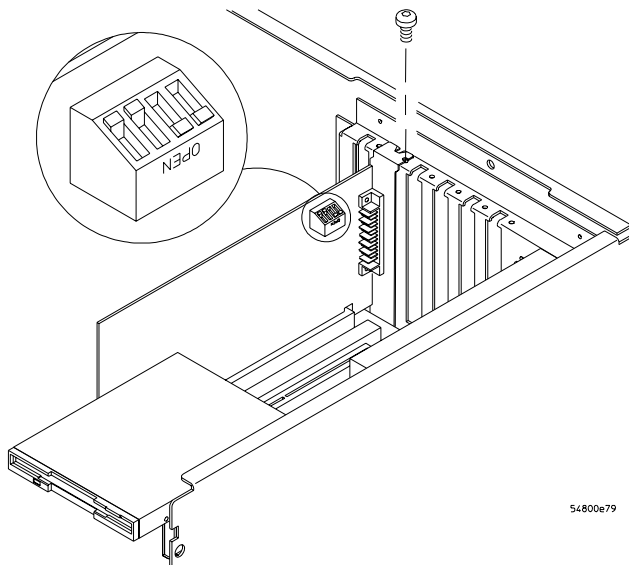

#### Removing the GPIB Interface Board

---

### To remove and replace the scope interface board and SVGA display board

Use these steps to remove and replace the scope interface board and SVGA display board. These boards must be removed and replaced as a unit. When necessary, refer to other removal procedures.

- 1** Disconnect the power cable and remove the cover.
- 2** Disconnect these cables from the scope interface board:
  - Acquisition cable W11
  - Keyboard cable W16
- 3** Disconnect these cables from the SVGA display board:
  - Display board to floppy cable W8
  - Display board to hard drive cable W10
  - Motherboard floppy cable W7
  - Motherboard hard drive cable W9
  - Backlight primary cable W17
  - Display video cable W20
- 4** Remove the two Torx T15 screws that secure the scope interface and SVGA display boards to the chassis.  
These screws are at the rear of the chassis.

Figure 6-19

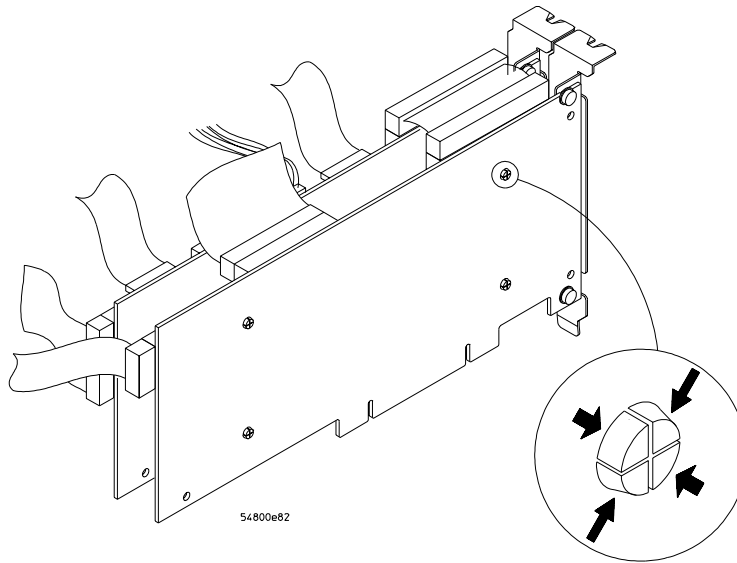

**Removing the Scope Interface and SVGA Display Boards**

- 5 Grasp the scope interface and SVGA display boards at the top corners and pull them straight up until they are free of the card cage.
- 6 To replace the scope interface and SVGA display boards, reverse the above procedure. Be sure to observe correct polarity on all cables when replacing the boards.

---

**To separate the scope interface board and SVGA display board**

Use this procedure to separate the scope interface board from the SVGA display board. When necessary, refer to other removal procedures.

- 1 Remove the scope interface board and the SVGA display board from the card cage.
- 2 Remove the display board jumper cable W14.  
See figure 6-19.
- 3 Use a small pair of pliers to gently compress each of the four studs at the back of the scope interface board until the stud slips through the board. (Later versions do not use the four studs — skip this step.)

---

**CAUTION**

**AVOID DAMAGE TO STUDS!**

Be careful not to scratch the circuit board. Also, do not compress the fingers of the studs too far, or they will be damaged. Compress the studs just far enough to allow them to slip through the board.

- 4 To re-assemble the boards, reverse the above procedure.



---

## To remove and replace the Option 200 sound card

Use this procedure to remove and replace the Option 200 VoiceControl sound card.

- 1** Disconnect the power cable and remove the cover.
- 2** Remove the Torx T15 screw that secures the sound card to the rear of the chassis.
- 3** Pull the card up to disengage it from the motherboard, then up and out of the chassis.

---

### **CAUTION**

AVOID DAMAGE TO CABLES!  
Be careful to not snag any of the cables.

- 4** To replace the card, reverse the removal procedure.

---

## To remove and replace the hard disk drive

Use these steps to remove and replace the hard disk drive. When necessary, refer to other removal procedures.

- 1 Disconnect the power cable and remove the cover.
- 2 Disconnect the hard disk interface cable W10 from the hard disk drive.
- 3 Remove the 4 Torx T15 screws that secure the hard disk drive bracket to the chassis.
- 4 Remove the 4 Torx T10 screws that secure the HDD to the bracket.

---

### CAUTION

DO NOT LET THE DISK DRIVE FALL!

Support the drive while removing the screws so that the drive does not fall.

- 5 Lift the hard disk out of the chassis. Store the disk in a safe place where it will not be bumped or dropped.
- 6 To replace the hard disk drive, reverse the above procedure. Ensure that you reconnect the disk cable with the correct polarity.

---

### CAUTION

DO NOT OVER TIGHTEN SCREWS!

Do not over tighten the T10 screws that secure the HDD to the bracket. Torque to 3 in-lbs.

- 7 Run the WINBIOS setup as described in the section “To configure the motherboard jumpers and set up the BIOS” in chapter 5.

Figure 6-20

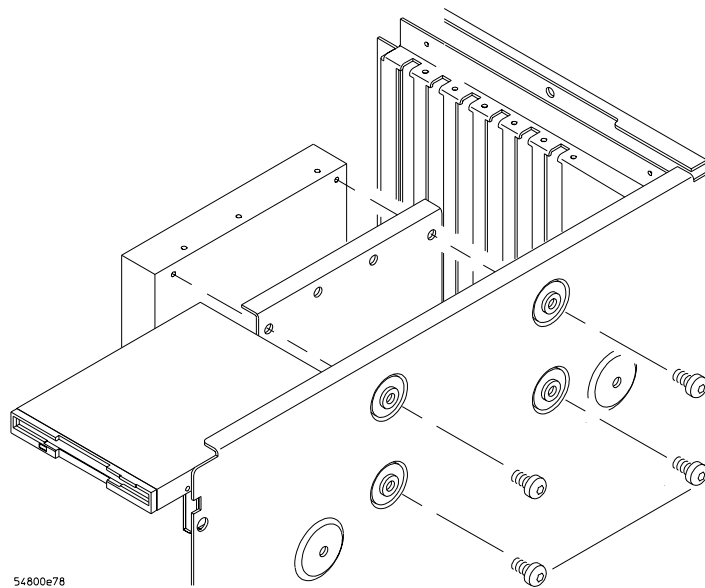

Removing the Hard Disk Drive

---

## To remove and replace the floppy disk drive

Use this procedure to remove and replace the floppy disk drive. When necessary, refer to other removal procedures.

- 1 Disconnect the power cable and remove the cover.
- 2 Disconnect the ribbon cable W8 at the disk drive.
- 3 Remove the two Torx T8 screws that secure the disk drive to the chassis.

Figure 6-21

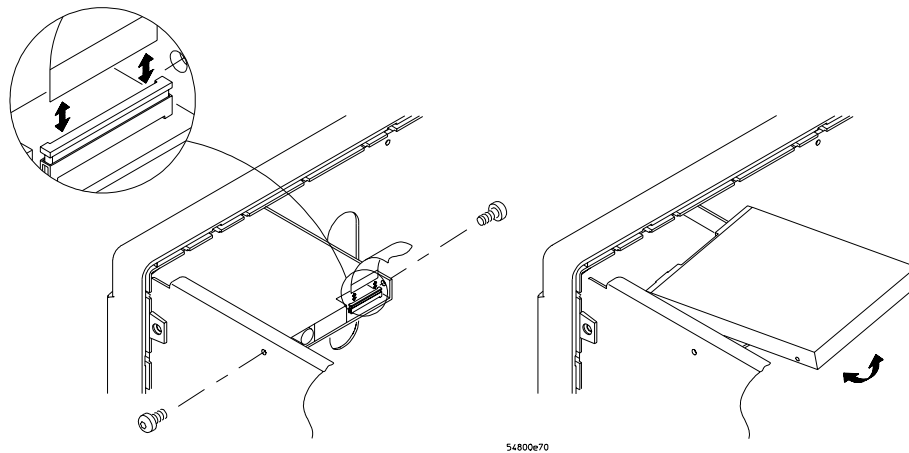

### Removing the Floppy Disk Drive

- 4 Slide the disk drive back and lift it out of the instrument.
- 5 To replace the floppy disk drive, reverse the above procedure.

---

## To remove and replace the motherboard

Use the following procedure to remove and replace the motherboard assembly. When necessary, refer to other removal procedures.

---

### CAUTION

REPLACE MOTHERBOARD WITH THE SAME TYPE!

Be sure to order the correct motherboard, and replace the motherboard with the same type.

- 1 Disconnect the power cable and remove the cover.
- 2 Disconnect the floppy disk drive cable W8 from the SVGA display board, then remove the floppy drive.
- 3 Disconnect the hard disk drive cable W10 from the SVGA display board, then remove the hard disk drive.
- 4 Remove the SVGA display board and the scope interface board assembly.
- 5 Remove the GPIB interface board.
- 6 Disconnect the power supply cable W5 from the motherboard. There are two connectors to unplug.

**7 Disconnect these cables from the motherboard:**

- Hard disk motherboard cable W9
- Floppy motherboard cable W7
- Serial port cables W24 and W25
- Parallel port cable W23
- Mouse connector cable W22

Set all cables out of the way.

**8 Remove the Torx T15 screw that holds the mouse connector plate to the back panel of the chassis and remove the mouse connector plate.**

**9 Remove the 8 Torx T10 screws that secure the motherboard to the chassis.**

**Figure 6-22**

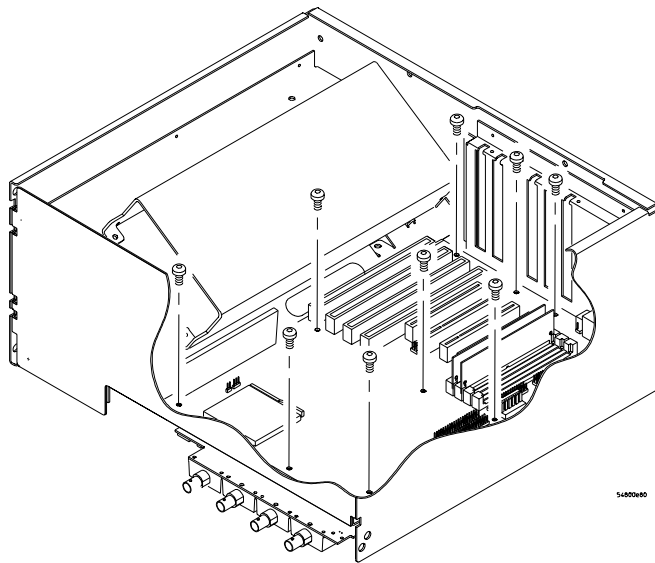

**Removing the Motherboard Torx Screws**

**10 Remove the motherboard from the chassis by lifting and tilting it over the power supply, being careful to clear the floppy drive bracket and all remaining cables.**

**11 To replace the motherboard assembly, reverse the above procedure. Note the following:**

- Replacement motherboards come without a CPU or RAM SIMMs. Transfer these from the old motherboard using the procedures in this chapter. Be sure to take appropriate antistatic measures.
- Newer motherboards may require a new CPU and the installation of a Voltage Regulator Module (VRM). RAM SIMMs may be transferred from the old motherboard.
- The corner of the motherboard underneath the floppy drive bracket fits into a small plastic bracket attached to the chassis.
- Be sure to observe polarity when reconnecting all the cables.
- Ensure that all jumpers are set correctly on the new motherboard before installation. See “To configure the motherboard jumpers and set up the BIOS” in chapter 5.

**12 Once an upgraded motherboard has been installed, turn on the instrument and run the WINBIOS setup procedure. See “To configure the motherboard jumpers and set up the BIOS” in chapter 5.**

- 13 Once the WINBIOS has been configured, cycle power to start the Windows '95 operating system and begin the plug-and-play driver installation. Note the following:
  - Expect several iterations of the plug-and-play recognition and driver installation. Use the Windows '95 drivers when available.
  - Obtain the 548xx driver disk by contacting the Agilent factory. When Windows '95 finds "Unknown PCI card" and displays the message "Insert Agilent Technologies 548XX Scope Installation Disk", insert the floppy disk, select drive A:, and click OK to load the oscilloscope driver.
  - The instrument will reboot several times to recognize all of the hardware.
- 14 Run the self-test to verify the instrument is operating properly. See "Self-Test Verification" in chapter 3.

---

## To remove and replace the power supply

Use these steps to remove the power supply assembly. When necessary, refer to other removal procedures.

---

### WARNING

#### SHOCK HAZARD!

If the power supply is defective, it could have a dangerous charge on some capacitors. This charge could remain for many days after removing power from the supply.

---

- 1 Disconnect the power cable and remove the cover.
- 2 Disconnect the cables W2, W3, and W4 from the front of the supply.  
Two of these (W3 and W4) have retaining latches underneath. Press the latch to release the plug from the connector.
- 3 Disconnect the line sync cable W6 from the rear of the supply.
- 4 Remove the Torx T15 screw that secures the power supply ground wire to the chassis.

Figure 6-23

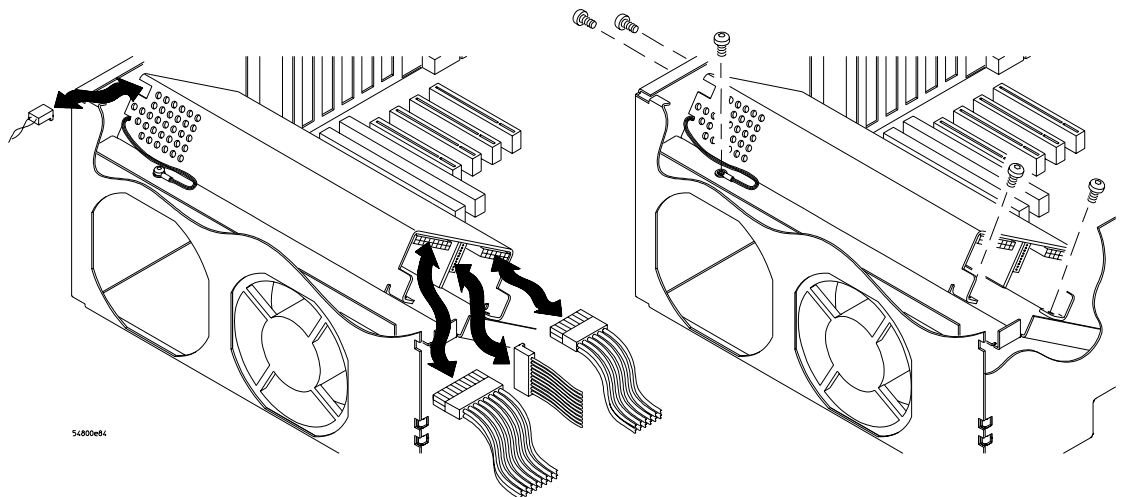

#### Removing Power Supply Cables

- 5 Remove the two Torx T10 screws that secure the front of the supply to the chassis.
- 6 Remove the two Torx T10 screws that secure the power supply to the back of the chassis.
- 7 Lift the supply up and out of the chassis.

**To remove and replace the fan**

- 8 To replace the supply, reverse the installation procedure. Ensure that the AC power connector is aligned with the cutout in the rear panel, that the supply chassis rests on the two tabs in the instrument chassis, and that the ground wire is routed through the notch at the rear of the power supply chassis.
  - Cable W2, which is the middle connector in front, connects to the pins toward the top of the supply.
  - To ensure electrical safety, you must reconnect the ground wire to the chassis.

---

## To remove and replace the fan

---

### WARNING

#### AVOID INJURY!

The fan blades are exposed both inside and outside the chassis. Disconnect the power cable before working around the fan. Use extreme caution in working with the instrument. Failure to observe these precautions may result in injury.

Use this procedure to remove and replace the fan. When necessary, refer to other removal procedures.

- 1 Disconnect the power cable and remove the cover.
- 2 Disconnect the fan cable W21 from the acquisition board.
- 3 Remove the four fasteners securing the fan to the chassis.

To remove a fastener, unscrew the center pin using a #1 Posidrive screwdriver. You may need to apply upward pressure at the point of the pin with a small screwdriver. After removing the center pin, compress the fastener body and push it up and out of the fan and chassis. Be sure to support the fan before removing the last fastener.

Alternatively, you can cut the fastener at the outside of the chassis with a pair of diagonal cutters, then install new fasteners when you replace the fan.

Figure 6-24

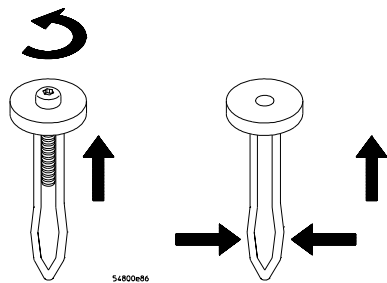

**Removing Fan Fasteners**

---

### CAUTION

#### AVOID OVERHEATING THE INSTRUMENT!

When replacing the fan, be sure the direction of the fan air flow is coming from the outside to the inside of the instrument. Check the flow arrows on the fan and check for proper flow once power is applied to the instrument. Improper air flow can overheat the instrument.

- 4 To install the fan, reverse this procedure.

---

## To remove and replace the CPU

Use this procedure to remove and replace the CPU. When necessary, refer to other removal procedures.

- 1 Disconnect the power cable and remove the cover.
- 2 Disconnect the CPU fan cable from the motherboard.
- 3 Pull the CPU socket release lever laterally away from the socket to disengage the lever from the locking tab. Then rotate the lever upward to release the CPU assembly from the socket.

**Figure 6-25**

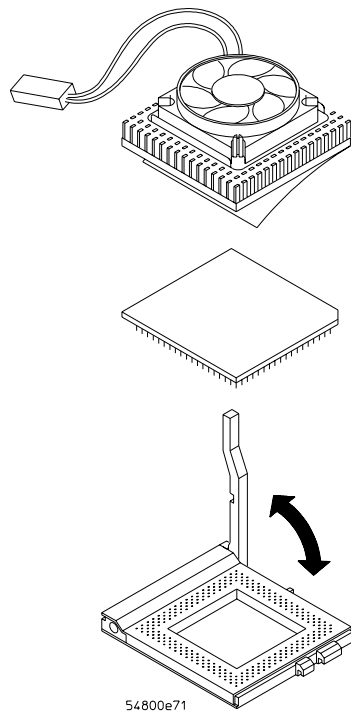

### Removing the CPU

- 4 Carefully lift the CPU assembly out of the socket. Place it into antistatic IC foam or another protective carrier.
- 5 To replace the CPU, reverse the assembly procedure. Be sure to re-assemble the CPU so that pin 1 of the CPU aligns with pin 1 of the socket.

---

## To remove and replace RAM SIMMs or SDRAM DIMMs

Use this procedure to remove the cover and disconnect cables, then remove and replace either SIMMs or DIMMs on the motherboard, depending on the type of motherboard in the oscilloscope. When necessary, refer to other removal procedures.

- 1 Disconnect the power cable and remove the cover.
- 2 Remove the hard disk drive.
- 3 Disconnect these cables from the motherboard connectors and set them aside:
  - Serial port cables W24 and W25
  - Parallel port cable W23
  - Mouse connector cable W22
  - Motherboard floppy cable W7
  - Motherboard hard drive cable W9

### Removing and replacing SIMMs on the AMI motherboard

Use this procedure if the oscilloscope has an AMI motherboard.

- 1 There are four SIMM sockets. Remove SIMMs starting with the SIMM closest to the chassis side panel. To remove each SIMM, push the retaining clips at each end to the side, then tilt the SIMM forward and pull it out.

Figure 6-26

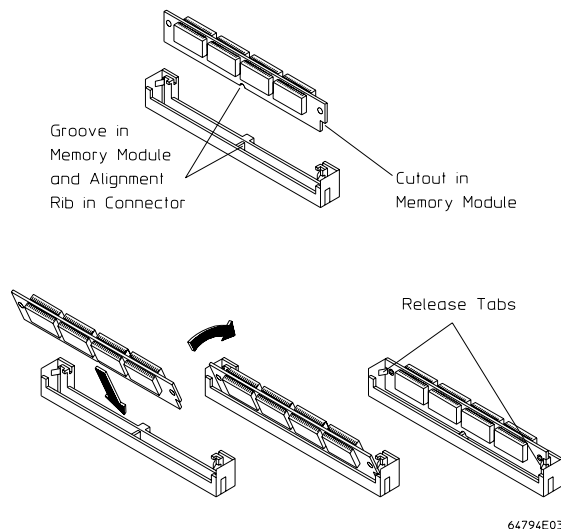

### Removing RAM SIMMs

- 2 To replace SIMMs, reverse the assembly procedure. Install SIMMs in the opposite order of removal. When the SIMM is correctly installed, the locating fingers on the SIMM socket will engage the holes in the SIMM, and the retaining clips will snap around the sides of the SIMM.

### Removing and replacing SDRAM DIMMs on the FIC motherboard (not pictured)

Use this procedure if the oscilloscope has an FIC motherboard.

- 1 Locate the DIMM slots on the FIC motherboard. Carefully pull the DIMM straight up and out of the slot.
- 2 Insert the new DIMM by pushing it straight down into the DIMM slot using both hands.
- 3 Make sure the clips on the slot close up to hold the DIMM in place when the DIMM touches the bottom of the slot.



---

## To remove and replace an attenuator

Use this procedure to remove and replace an attenuator assembly. When necessary, refer to other removal procedures.

---

### CAUTION

#### ELECTROSTATIC DISCHARGE!

Use grounded wrist straps and mats when servicing the acquisition board. Electrostatic discharge can damage electronic components.

---

**Do Not Remove the Attenuators from the Acquisition Board**

Attenuators are part of the acquisition board. When replacing the acquisition assembly, do not remove the attenuators.

- 1 Remove the acquisition board.
- 2 From the bottom of the acquisition board, remove the two Torx T10 screws that secure the attenuator.
- 3 A 24-pin connector, located at the rear of and inside the attenuator, connects it to the PC board. With a gentle rocking or prying motion, lift the attenuator from the PC board. Use a small flat-blade screwdriver, prying at the rear between the attenuator and PC board, to help control attenuator removal.

Figure 6-27

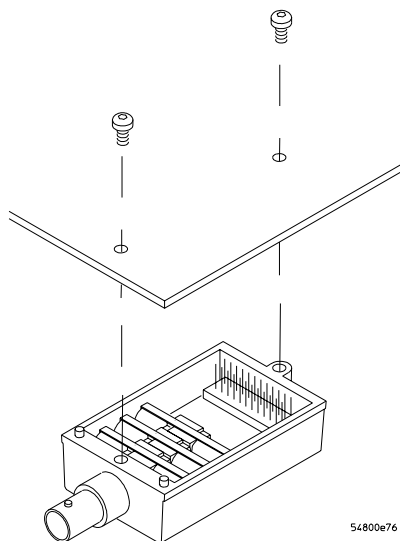

Removing an Attenuator

- 4 To replace an attenuator:
  - a Position the attenuator over the PC board 24-pin connector and push the connectors together.
  - b Using a nonmetallic tool inserted through the hole in the attenuator cover, gently push to fully seat the connectors.
  - c Replace the two Torx T10 screws and tighten to 0.57 Nm (5 in-lbs).

**If You Permanently Replace Parts**

If you have permanently changed any combination of acquisition board, attenuator, or acquisition hybrid, you will need to adjust the high-frequency pulse response on the affected channels.

For example:

If you permanently swap two attenuators or acquisition hybrids during troubleshooting, you must adjust the channels affected.

If you replace one attenuator or hybrid, you must adjust that channel.

If you replace the acquisition board, you must adjust all channels.

Also, when you replace acquisition system components, you should rerun the self-calibration routines prior to performance verification or use of the instrument.

---

## To reset the attenuator contact counter

- 1 Turn off the Infiniium oscilloscope.
- 2 Connect a mouse and a keyboard to the oscilloscope.
- 3 Insert the service disk in the floppy drive and turn on the oscilloscope. For units equipped with a 120 Mbyte floppy drive, do not insert the service disk until the message: Starting Windows 9X... appears on the screen.
- 4 The oscilloscope will boot into the Windows® operating system.
- 5 Press Control-Esc on the keyboard to access the Windows® Start menu.
- 6 Open the Programs group and click the Infiniium Scope icon.
- 7 When the oscilloscope application comes up, click the mouse icon in the upper right corner of the screen.
- 8 Click the Utility pull down menu, then click Self Test. In the Self Test screen, click Select Service Extensions.
- 9 Click the Self Test pull down menu, scroll down and select Atten Set.

Figure 6-28

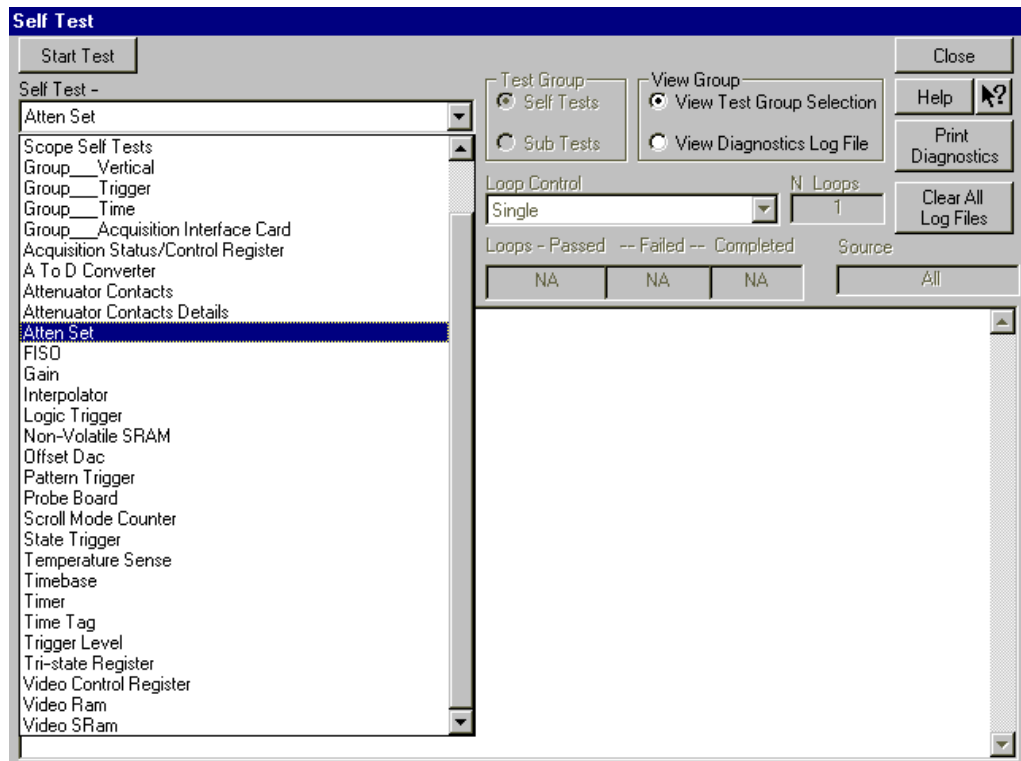

Self Test

- 10 Click the Start Test button. A screen like the following will be displayed.

Figure 6-29

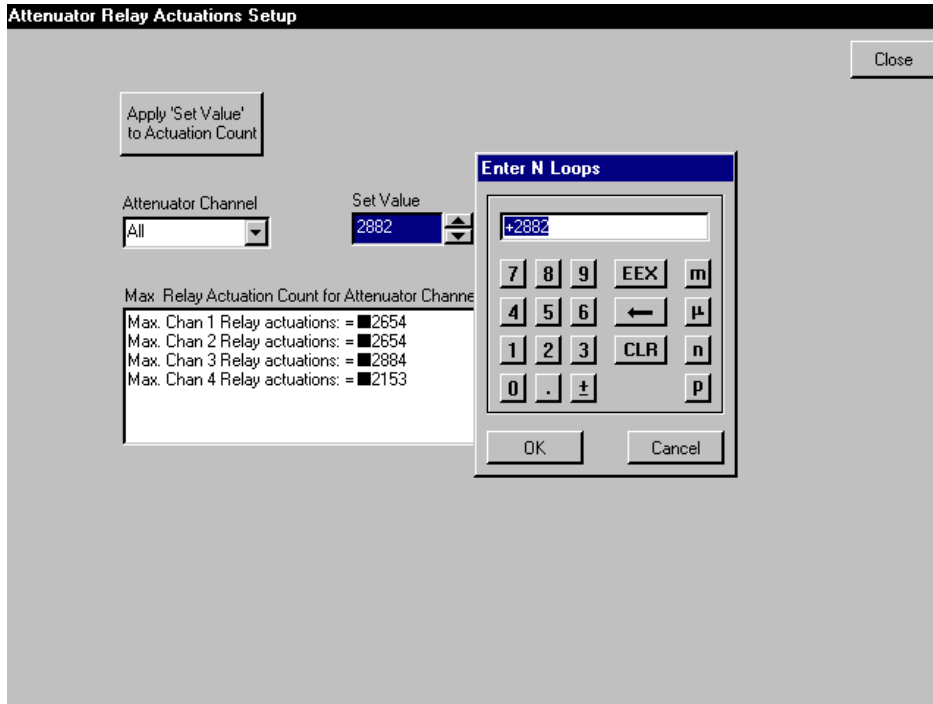

**Attenuator Relay Actuations Setup**

- 11 In the Attenuator Channel box, select the channel you are changing.
- 12 Under Set Value, enter the corrected attenuator value using the keyboard or the drop down keypad, then press the button labeled Apply 'Set Value' to Actuation Count.
- 13 Repeat for each channel you need to change.

---

## To remove and replace an acquisition hybrid

Use the following procedure to remove and replace an acquisition hybrid. When necessary, refer to other removal procedures.

---

### CAUTION

#### ELECTROSTATIC DISCHARGE!

Use grounded wrist straps and mats when servicing the acquisition board. Electrostatic discharge can damage electronic components.

You do not have to remove the acquisition board before replacing an acquisition hybrid. To understand the sequence of parts, use the accompanying illustration.

#### To remove the acquisition hybrid

- 1 Disconnect the power cable and remove the cover.
- 2 Use a T-6 Torx driver to remove two screws that secure the heatsink spring, then remove the heatsink.
- 3 Use a 3/16 hex driver to remove two standoffs that secure the top plate.
- 4 Use a T-6 Torx driver to remove the two screws that secure the top plate.
- 5 Remove the top plate.
- 6 Grasp the hybrid across the diagonal corners (one of which has a white mark) using your thumb and index finger. Then lift the hybrid off of the connector assembly.

#### To replace the acquisition hybrid

The location of pins and other locator features will guide the alignment of parts. This assembly cannot be assembled incorrectly without forcing.

- 1 Install the hybrid with the three corner holes over the three large locator pins.
- 2 Install the top plate with the three cut-out corners over the three locator pins.

---

### CAUTION

#### DO NOT USE EXCESSIVE FORCE!

Tighten the hybrid carefully. Excess force or improper procedure may break the hybrid, which is very expensive to replace.

- 3 Loosely install the two hex standoffs along the long dimensions of the top plate.
- 4 Loosely install the two M2 pan-head screws.
- 5 Use a 5 mm (3/16 in) torque driver set to 0.34 Nm (3 in-lbs) to tighten the standoffs in the following sequence.
  - a Tighten any standoff to specifications.
  - b Tighten the standoff directly opposite the first one to specifications.
  - c Tighten the remaining two screws to specifications, using the Torx T6 torque driver set to 0.34 Nm (3 in-lbs).
- 6 Check for the graphite pad on the underside of the heatsink, then install it with the hole that is near one corner toward the front of the instrument.

When the heatsink is installed properly, you will be able to see the adjustment potentiometer through the hole in the heatsink.
- 7 Install the heatsink spring with the curve down.
- 8 Install the two heatsink screws. Use a T6 torque driver set to 0.34 Nm (3 in-lbs) to tighten them.

**If You Permanently Replace Parts**

If you have permanently changed any combination of acquisition board, attenuator, or acquisition hybrid, you will need to adjust the high-frequency pulse response on the affected channels.

For example:

If you permanently swap two attenuators or acquisition hybrids during troubleshooting, you must adjust the channels affected.

If you replace one attenuator or hybrid, you must adjust that channel.

If you replace the acquisition board, you must adjust all channels.

Also, when you replace acquisition system components, you should rerun the self-calibration routines prior to performance verification or use of the instrument.

**The Hybrid Connector**

As shown in the illustration, two screws through the hybrid connector hold the bottom plate to the underside of the PC board. If you remove the connector, the bottom plate can fall away from the board.

Sometimes the plate will stick to the bottom of the board by itself because of adhesives that fasten an insulator to the plate. If the connector is very gently removed and replaced, you might be able to replace the connector without removing the acquisition board. The key is to apply very little pressure while removing the connector screws. Too much pressure will push the plate away from the bottom of the board. If the plate falls from the board, you will have to remove the acquisition board to re-install the connector. If the plate does not fall from the board, you will have saved some time and work.

To replace a connector:

- 1 Remove the acquisition board from the instrument.
- 2 Follow the procedure for removing the hybrid.
- 3 Remove the two screws to remove the connector.
- 4 Re-assemble by following all procedures, taking note of the following:
  - Use a T6 torque driver set to 0.34 Nm (3 in-lbs) to tighten the hybrid connector screws.

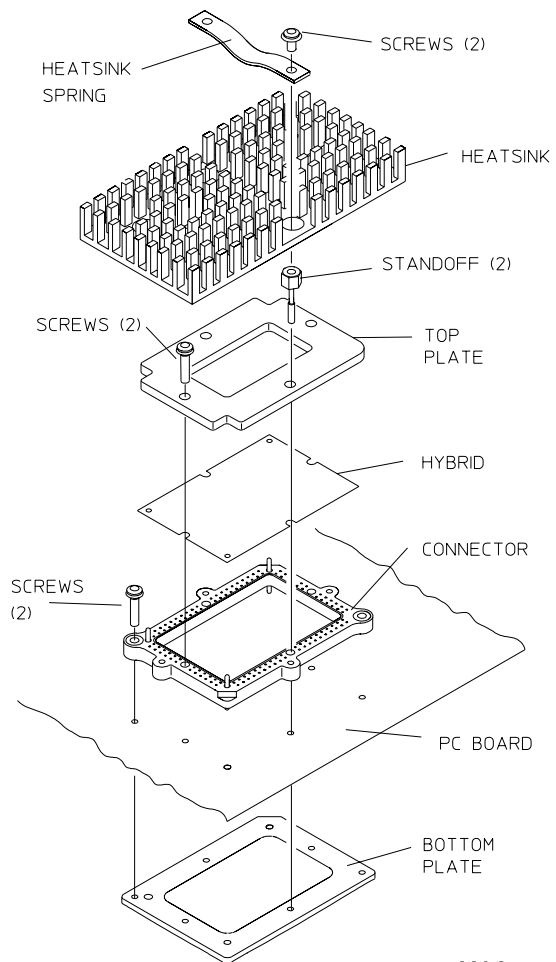

54542e13

Ordering Replaceable Parts 7-2  
    Listed Parts 7-2  
    Unlisted Parts 7-2  
    Direct Mail Order System 7-2  
    Exchange Assemblies 7-2  
Power Cables and Plug Configurations 7-3  
Exploded Views 7-4  
Replaceable Parts List 7-15

---

# Replaceable Parts

This chapter of the *Agilent Technologies 54810A/15A/20A/25A Oscilloscope Service Guide* includes information for ordering parts. Service support for this instrument is replacement of parts to the assembly level. The replaceable parts include assemblies and chassis parts.

---

## Ordering Replaceable Parts

### Listed Parts

To order a part in the parts list, quote the Agilent Technologies part number, indicate the quantity desired, and address the order to the nearest Agilent Technologies Sales Office.

### Unlisted Parts

To order a part not listed in the parts list, include the instrument part number, instrument serial number, a description of the part (including its function), and the number of parts required. Address the order to the nearest Agilent Technologies Sales Office.

### Direct Mail Order System

Within the USA, Agilent Technologies can supply parts through a direct mail order system. There are several advantages to this system:

- Direct ordering and shipping from the Agilent Technologies parts center in California, USA.
- No maximum or minimum on any mail order. (There is a minimum amount for parts ordered through a local Agilent Technologies Sales Office when the orders require billing and invoicing.)
- Prepaid transportation. (There is a small handling charge for each order.)
- No invoices.

In order for Agilent Technologies to provide these advantages, please send a check or money order with each order.

Mail order forms and specific ordering information are available through your local Agilent Technologies Sales Office. Addresses and telephone numbers are located in a separate document shipped with the manuals.

### Exchange Assemblies

Some parts used in this instrument have been set up for an exchange program. This program allows the customer to exchange a faulty assembly with one that has been repaired, calibrated, and performance-verified by the factory. The cost is significantly less than that of a new part. The exchange parts have a part number in the form XXXXX-695XX.





After receiving the repaired exchange part from Agilent Technologies, a United States customer has 30 days to return the faulty assembly. For orders not originating in the United States, contact the local Agilent Technologies service organization. If the faulty assembly is not returned within the warranty time limit, the customer will be charged an additional amount. The additional amount will be the difference in price between a new assembly and that of an exchange assembly.

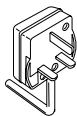

## Power Cables and Plug Configurations

This instrument is equipped with a three-wire power cable. The type of power cable plug shipped with the instrument depends on the country of destination. The following figure shows option numbers of available power cables and plug configurations.

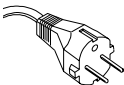
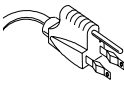
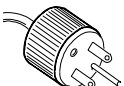
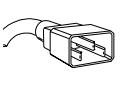
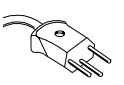
### Power Cables and Plug Configurations

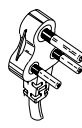
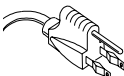
Plug Type	Cable Part No.	Plug Description	Length (in/cm)	Color	Country
Opt 900 250V 	8120-1351 8120-1703	Straight *BS1363A 90°	90/228 90/228	Gray Mint Gray	United Kingdom, Cyprus, Nigeria, Zimbabwe, Singapore
Opt 901 250V 	8120-1369 8120-0696	Straight *NZSS198/ASC 90°	79/200 87/221	Gray Mint Gray	Australia, New Zealand
Opt 902 250V 	8120-1689 8120-1692 8120-2857	Straight *CEE7-Y11 90° Straight (Shielded)	79/200 79/200 79/200	Mint Gray Mint Gray Coco Brown	East and West Europe, Saudi Arabia, So. Africa, India (unpolarized in many nations)
Opt 903** 125V 	8120-1378 8120-1521 8120-1992	Straight *NEMA5-15P 90° Straight (Medical) UL544	90/228 90/228 96/244	Jade Gray Jade Gray Black	United States, Canada, Mexico, Phillipines, Taiwan
Opt 904** 250V 	8120-0698	Straight *NEMA6-15P	90/228	Black	United States, Canada
Opt 905 250 V 	8120-1396 8120-1625	CEE22-V1 (System Cabinet Use) 250V	30/76 96/244	Jade Gray	For interconnecting system components and peripherals. United States and Canada only.
Opt 906 250V 	8120-2104 8120-2296	Straight *SEV1011 1959-24507 Type 12 90°	79/200 79/200	Mint Gray Mint Gray	Switzerland
Opt 912 220V 	8120-2956 8120-2957	Straight *DHCK107 90°	79/200 79/200	Mint Gray Mint Gray	Denmark
Opt 917 250V 	8120-4211 8120-4600	Straight SABS164 90°	79/200 79/200	Jade Gray	Republic of South Africa India
Opt 918 100V 	8120-4753 8120-4754	Straight MITI 90°	90/230 90/230	Dark Gray	Japan

\* Part number shown for plug is industry identifier for plug only. Number shown for cable is Agilent Technologies part number for complete cable including plug.

\*\* These cords are included in the CSA certification approval of the equipment.

E = Earth Ground

L = Line

N = Neutral

## Exploded Views

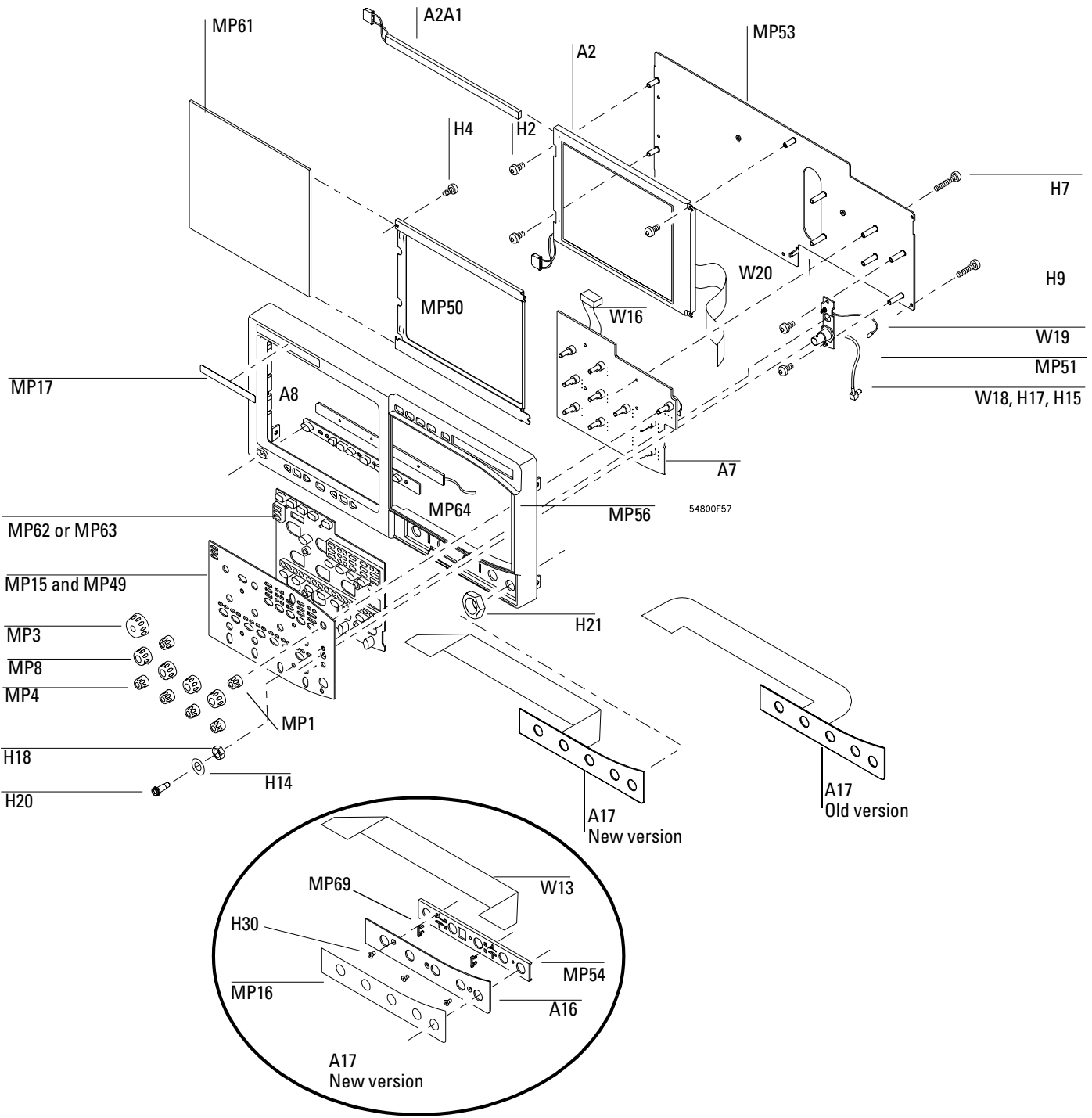

**Front Frame and Front Panel**

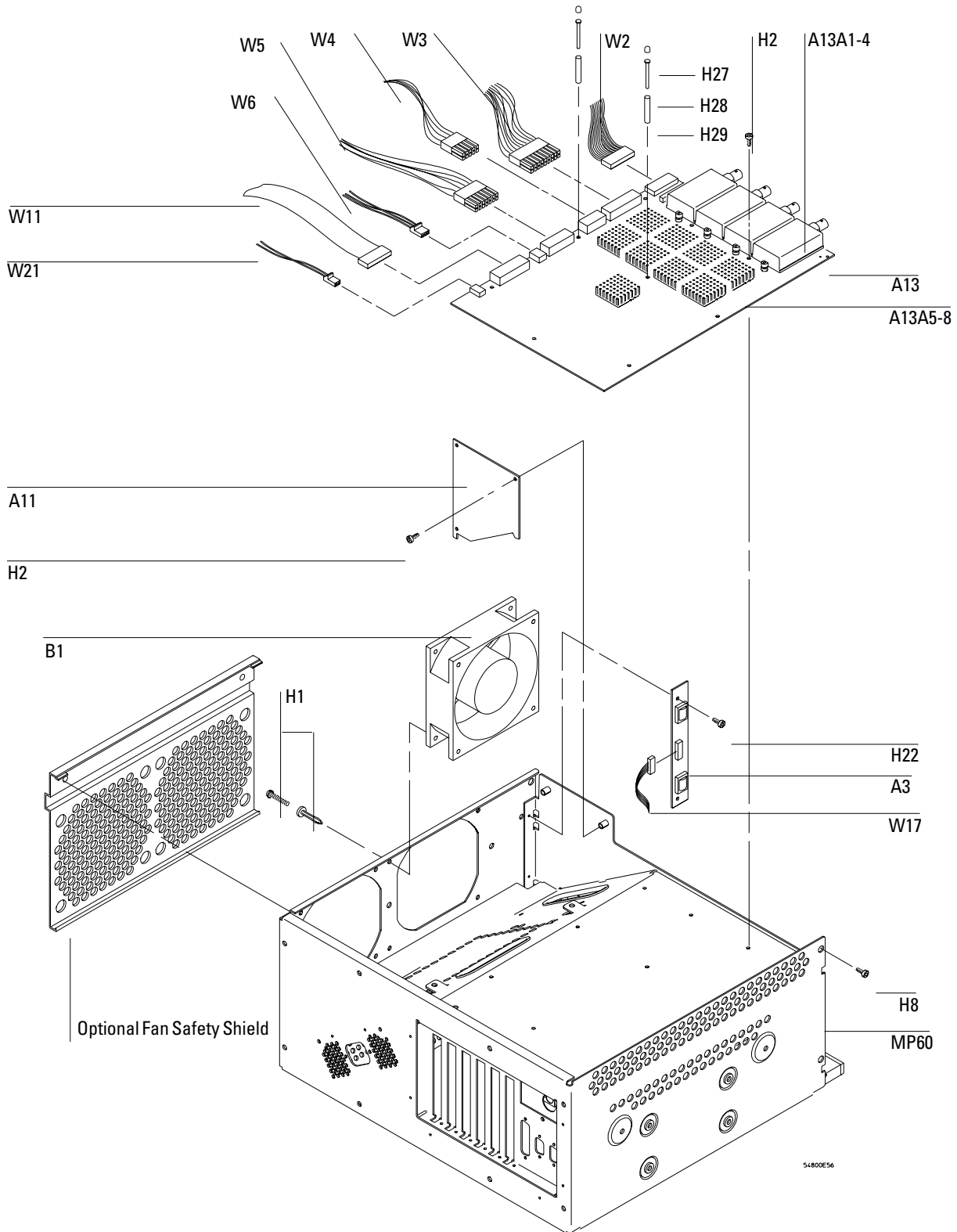

Fan and Acquisition Assembly

Chapter 7: Replaceable Parts  
**Exploded Views**

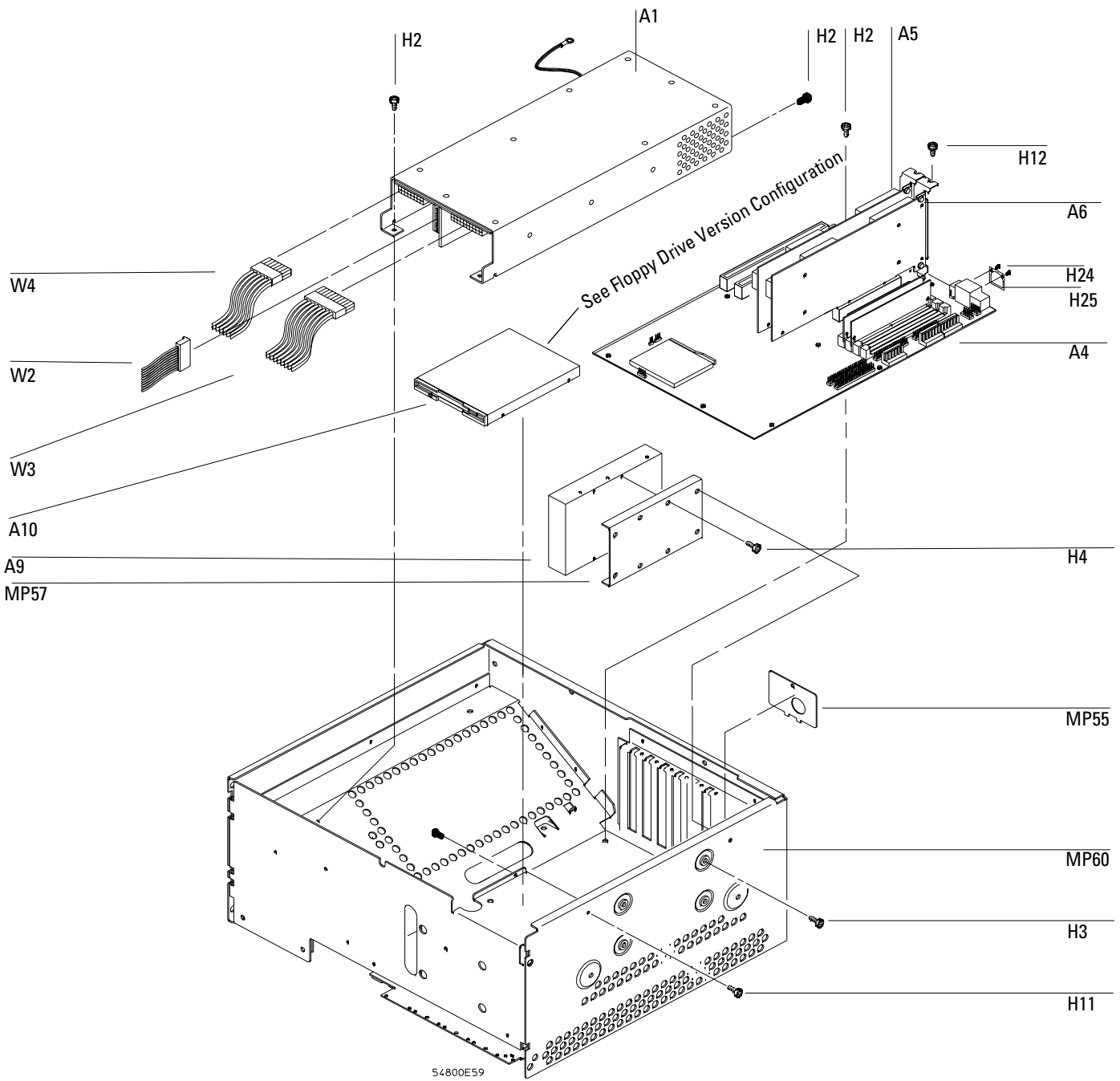

**Power Supply and PC Motherboard**

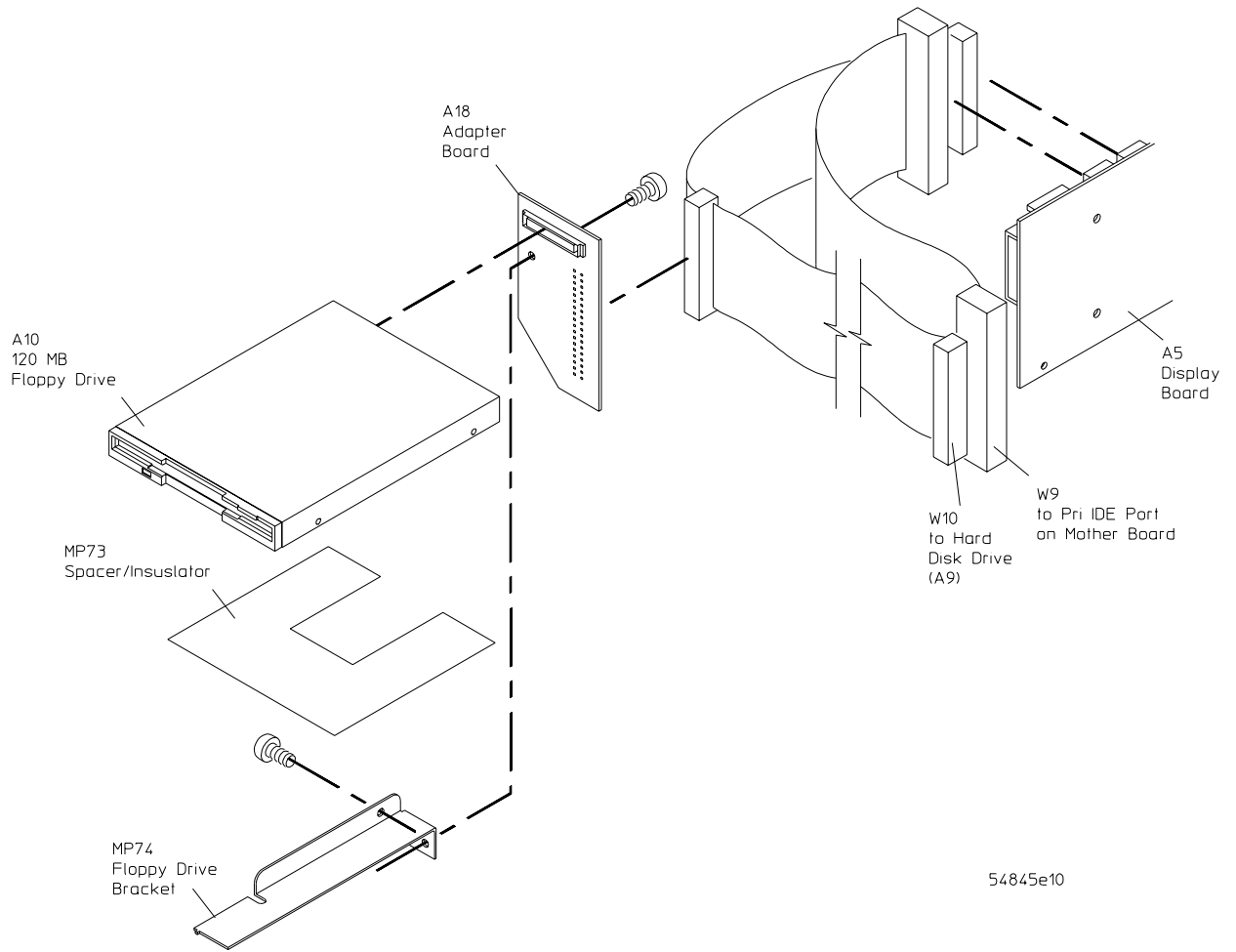

**120 Mbyte Floppy Drive Configuration with AMI Motherboard**

**Chapter 7: Replaceable Parts  
Exploded Views**

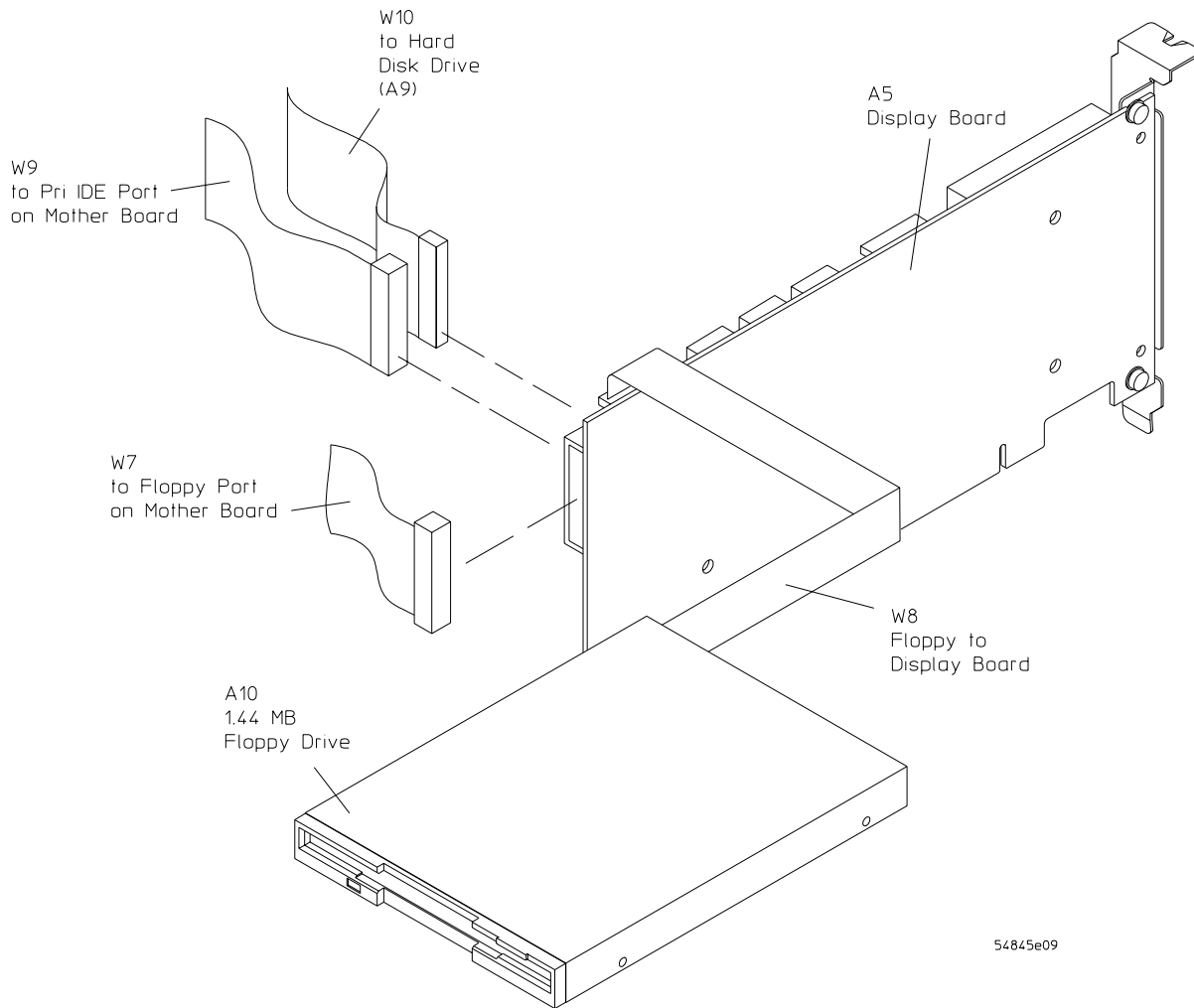

**1.44 Mbyte Floppy Drive Configuration on AMI Motherboard**

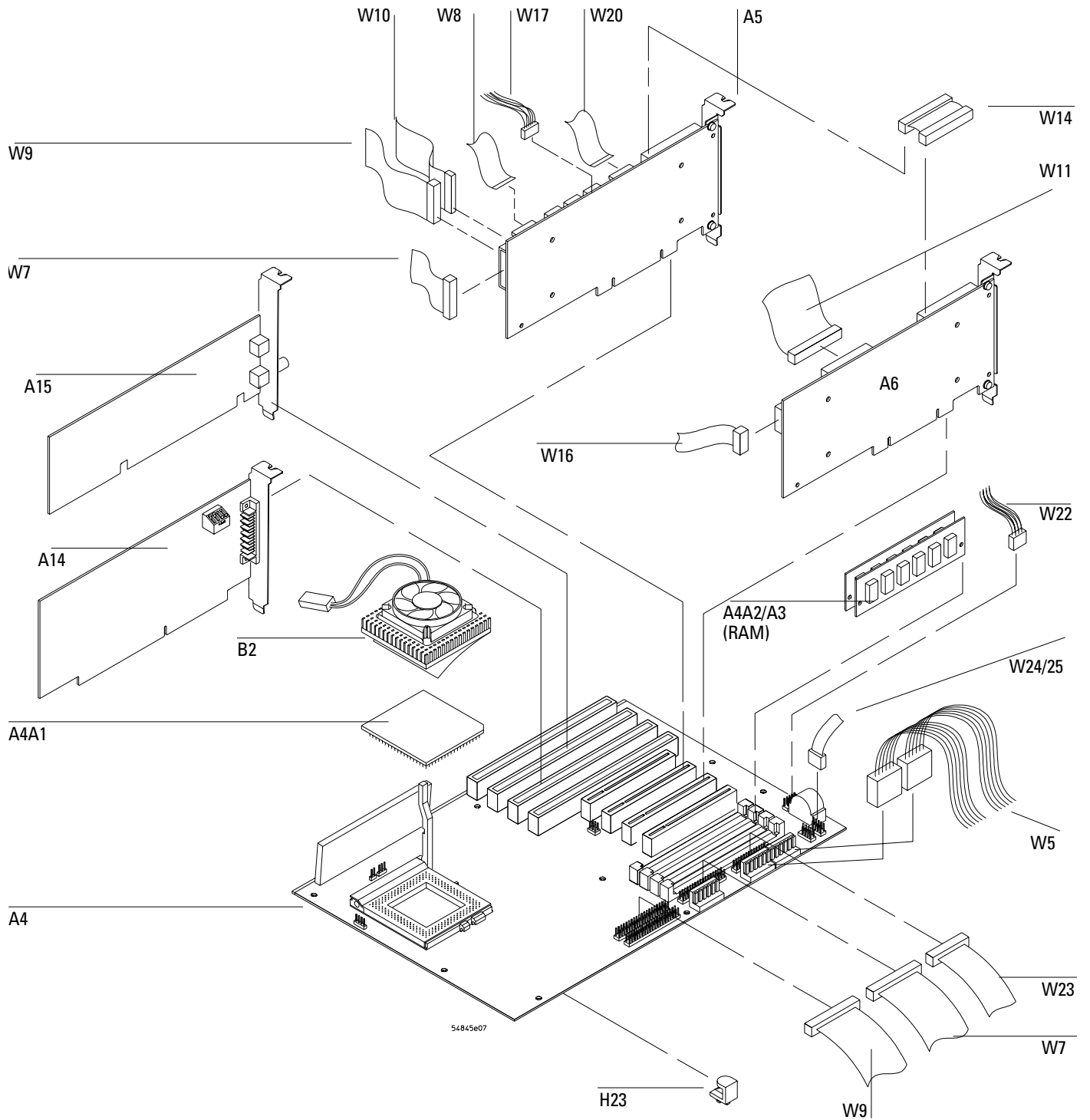

**AMI Series 727 (Atlas PCI-II) Motherboard for PC Motherboard Configuration 1**

Chapter 7: Replaceable Parts  
Exploded Views

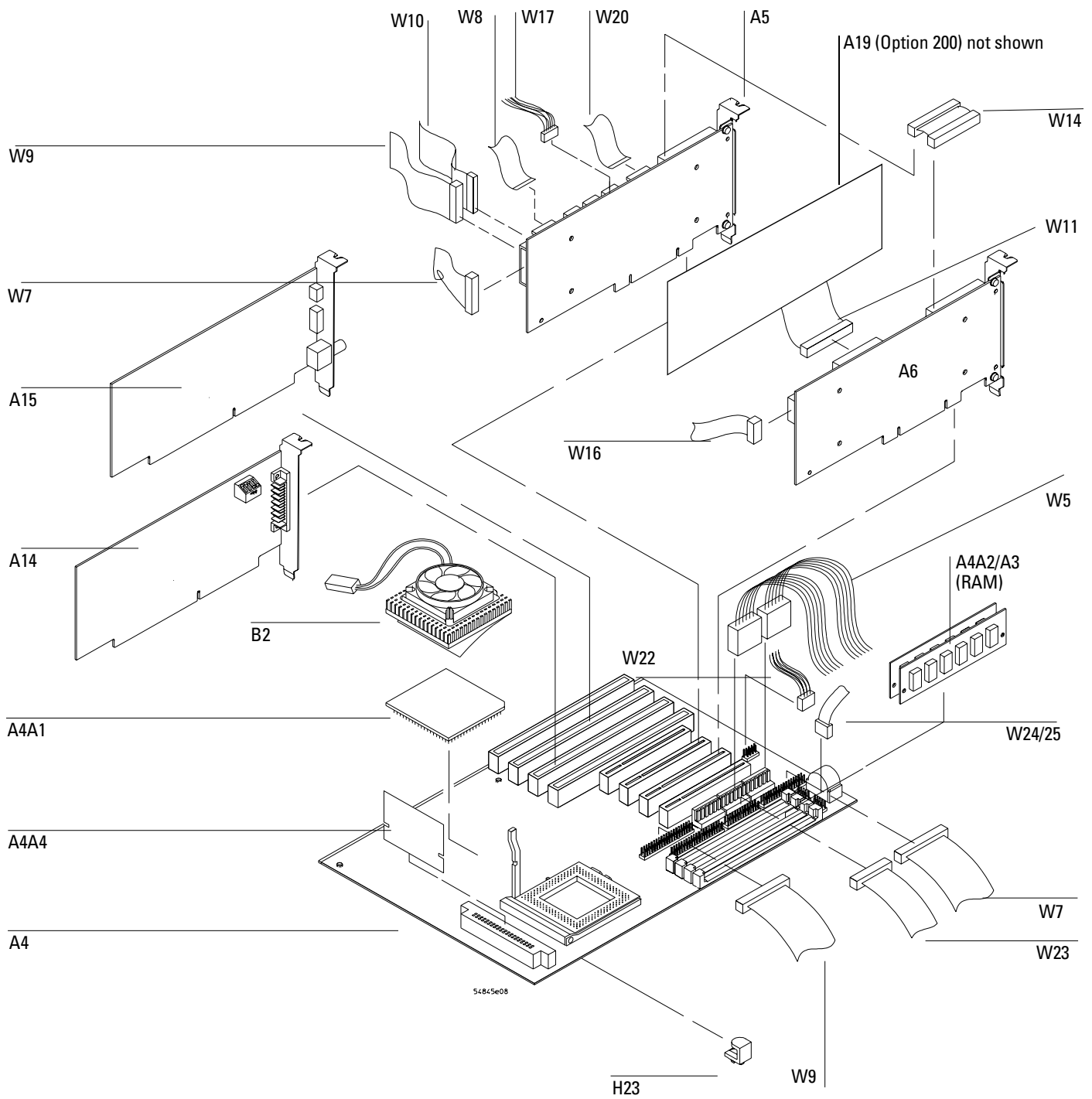

AMI Series 757 (Atlas PCI-III) Motherboard for PC Motherboard Configurations 2, 3, and 4



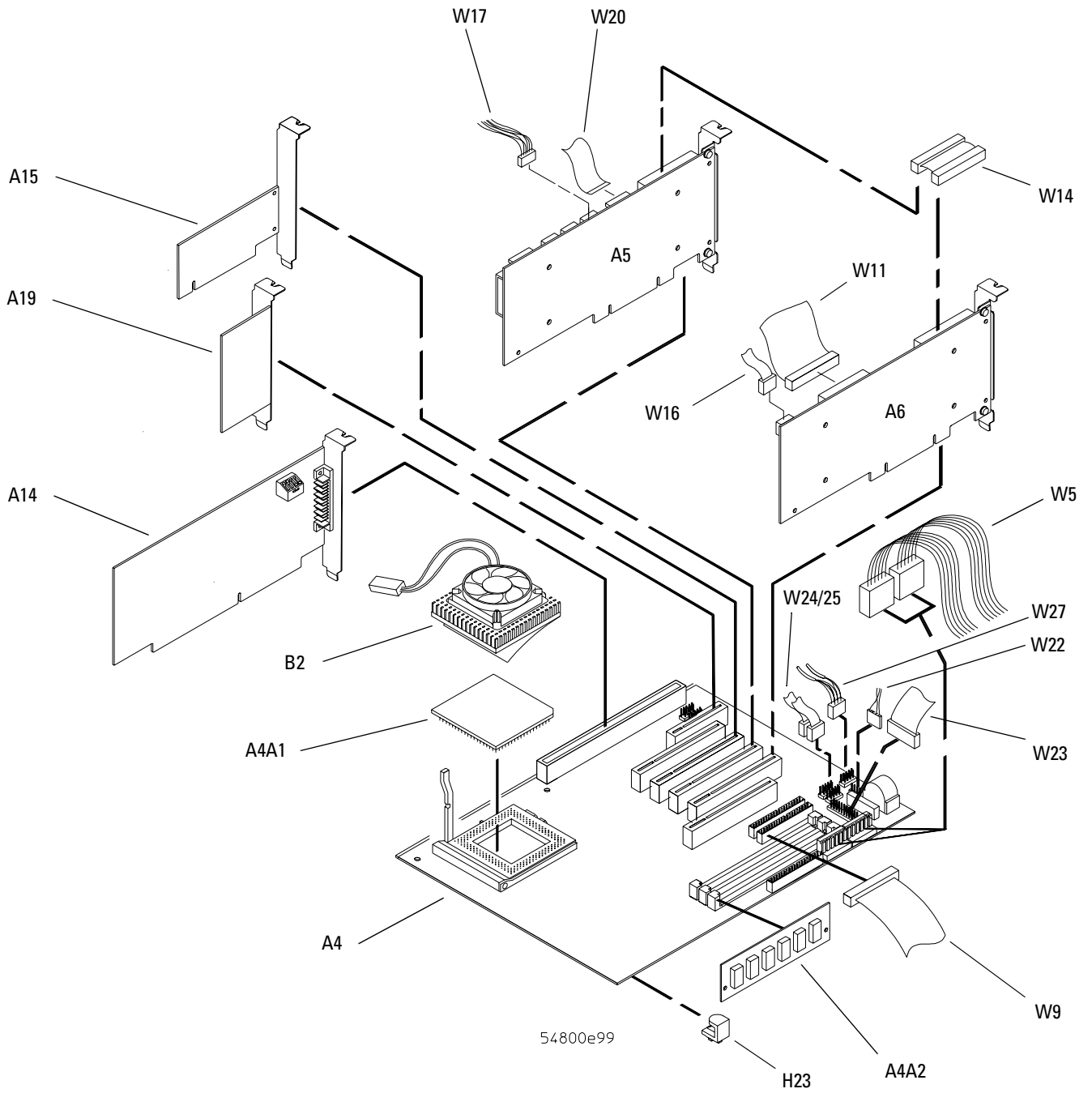

**FIC VA-503A Motherboard for PC Motherboard Configuration 5**

Chapter 7: Replaceable Parts  
**Exploded Views**

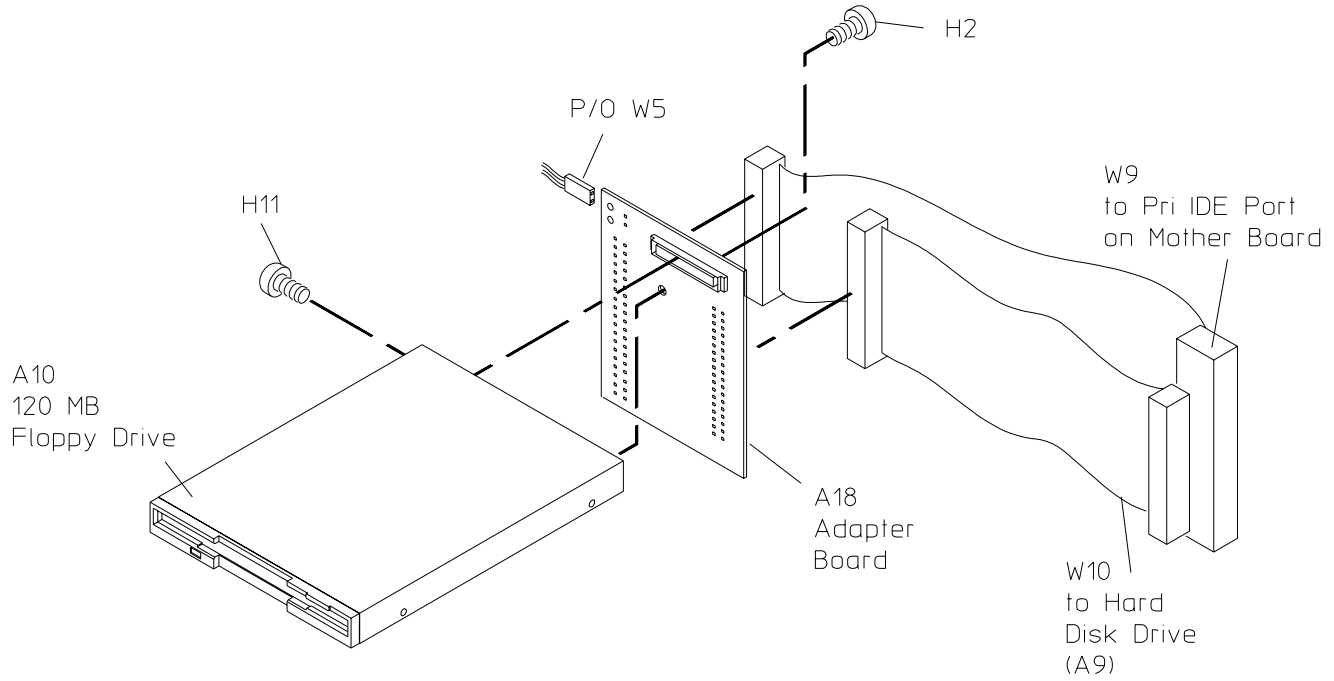

54845e10

**120 MByte Floppy Drive Configuration with FIC Motherboard for PC Motherboard Configuration 5**

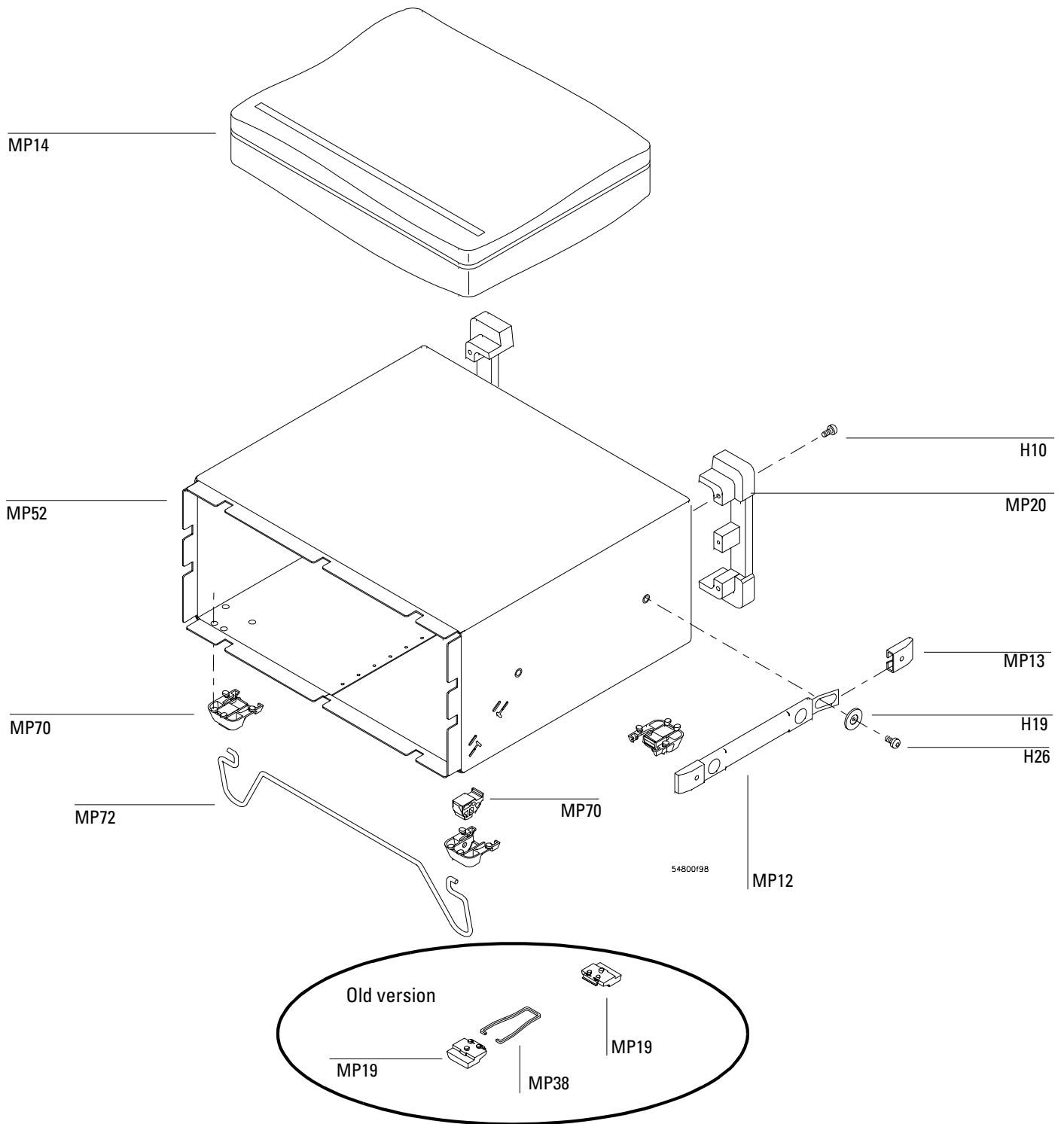

**Sleeve and Accessory Pouch**

Chapter 7: Replaceable Parts  
**Exploded Views**

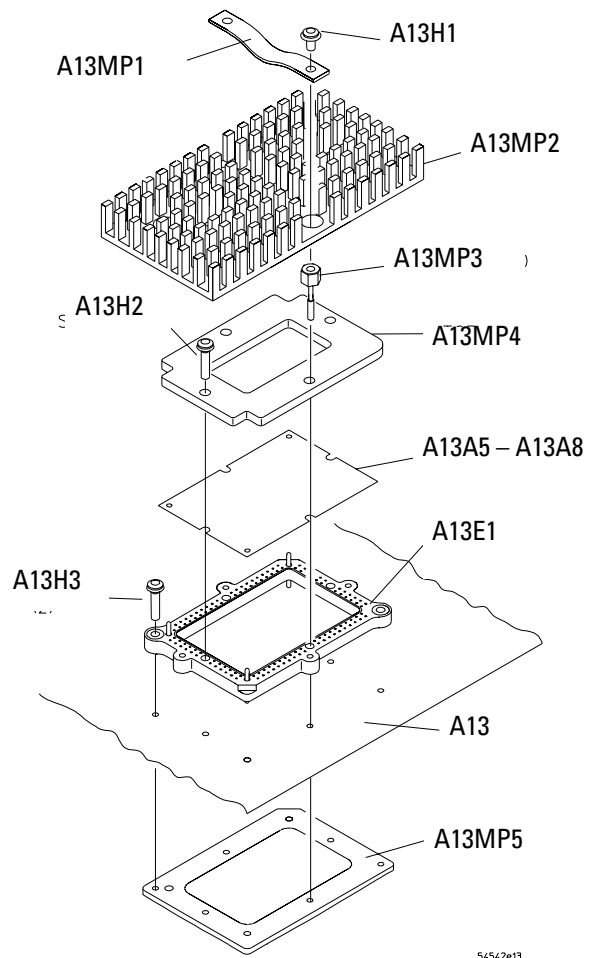

**Attenuator Assembly**

---

## Replaceable Parts List

The following table is a list of replaceable parts and is organized as follows:

- Exchange assemblies in alphanumeric order by reference designation.
- External chassis parts in alphanumeric order by reference designation. These parts are generally those that take the physical wear and tear of use.
- Internal parts in several categories. Each category is in alphanumeric order by reference designation. Replacing these parts generally requires opening the cabinet.

The information given for each part consists of the following:

- Reference designation.
- Agilent Technologies part number.
- Total quantity (QTY) in instrument or on assembly. The total quantity is given once and at the first appearance of the part number in the list.
- Description of the part.

Chapter 7: Replaceable Parts  
**Replaceable Parts List**

---

**Replaceable Parts**

---

<b>Ref. Des.</b>	<b>Agilent Part Number</b>	<b>QTY</b>	<b>Description</b>
<b>Exchange Assemblies</b>			
A13	54810-69527	1	2-CH ACQUISITION ASSEMBLY W/ATTENUATORS (Agilent 54810A)
A13	54815-69527	1	4-CH ACQUISITION ASSEMBLY W/ATTENUATORS (Agilent 54815A)
A13	54820-69527	1	2-CH ACQUISITION ASSEMBLY W/ATTENUATORS (Agilent 54820A)
A13	54825-69527	1	4-CH ACQUISITION ASSEMBLY W/ATTENUATORS (Agilent 54825A)
<b>External Chassis Parts</b>			
MP1	54801-47401	2	KNOB 12 MM GRAY
MP2	54801-47402	1	KNOB 18 MM GRAY (54810A / 54820A)
MP3	54801-47403	1	KNOB 24 MM GRAY
MP4	54801-47404	1	KNOB 12 MM YELLOW
MP5	54801-47405	1	KNOB 12 MM GREEN
MP6	54801-47406	1	KNOB 12 MM PURPLE (54815A / 54825A)
MP7	54801-47407	1	KNOB 12 MM PINK (54815A / 54825A)
MP8	54801-47408	1	KNOB 18 MM YELLOW
MP9	54801-47409	1	KNOB 18 MM GREEN
MP10	54801-47410	1	KNOB 18 MM PURPLE (54815A / 54825A)
MP11	54801-47411	1	KNOB 18 MM PINK (54815A / 54825A)
MP12	54810-44901	1	MOLDED-OVER HANDLE
MP13	54810-45001	2	END CAP - HANDLE
MP14	54810-68701	1	ACCESSORY POUCH
MP15	54810-94301	1	LABEL-INTERFACE (54810A/20A) (2 CH)
MP15	54815-94301	1	LABEL-INTERFACE (54815A/25A) (4 CH)
MP16	54810-94305	1	LABEL BNC-2 CH (54810/54820)
MP16	54815-94304	1	LABEL BNC-4 CH (54815/54825)
MP17	54815-94303	1	LABEL-LOGO/54810A/54815A (Infinitiium 500 MHz 1 GSa/s)
MP17	54825-94303	1	LABEL-LOGO/54820A/54825A (Infinitiium 500 MHz 2 GSa/s)
MP19	5041-9167	2	FOOT-BOTTOM (Old Version)
MP19	5041-9168	2	FOOT-BOTTOM NON-SKID (Old Version)
MP20	5042-1753	2	FOOT-REAR
MP21	C3751-60201	1	MOUSE
MP22	54810-85903	1	MOUSE PAD
MP23	E2610-60001	1	KEYBOARD (OPTIONAL FOR SERIAL NUMBERS US37349999 and BELOW)
MP38	1460-1345	2	TILT STAND (Old Version)
MP70	54810-61001	4	FOOT W/Insert (New Version)
MP72	54810-03700	1	TILT STAND (New Version)
W1	8120-1521	1	CABLE-POWER (standard 125V USA)
W1	8120-1703		CABLE-POWER (Option 900-UK)
W1	8120-0696		CABLE-POWER (Option 901-AUSTL)
W1	8120-1692		CABLE-POWER (Option 902-EUR)
W1	8120-0698		CABLE-POWER (Option 904-250V USA/CANADA)
W1	8120-2296		CABLE-POWER (Option 906-SWIT)
W1	8120-2957		CABLE-POWER (Option 912-DEN)
W1	8120-4600		CABLE-POWER (Option 917-AFRICA)
W1	8120-4754		CABLE-POWER (Option 918-JAPAN)
<b>Electrical Assemblies</b>			
A1	0950-3252	1	POWER SUPPLY
A2	2090-0396	1	COLOR FLAT-PANEL DISPLAY
A3	0950-3235	1	INVERTER-DISPLAY BACKLIGHT

---

**Replaceable Parts**

---

<b>Ref. Des.</b>	<b>Agilent Part Number</b>	<b>QTY</b>	<b>Description</b>
------------------	----------------------------	------------	--------------------

**To identify the motherboard configuration, see "To configure the motherboard jumpers and set up the BIOS in chapter 5.**  
 Depending on the motherboard configuration, determine which hard drive, motherboard, CPU, RAM, floppy drive, chassis, and cables are used in your unit.

**PC Motherboard Configuration 1 (AMI 727 Motherboard w/1.44 MByte Floppy Drive)(serial prefix range US37349999 and below)<sup>1</sup>**

A4	54810-66510	1	PC Motherboard AMI Series 727 (Atlas PCI-II)
A4A1	1821-3602	1	Microprocessor - AMD-K5-PR133 (100 MHz)
A4A2-3	1818-6172	2	DRAM-SIMM 2MX32 (8 MB SIMM)
A9	54810-68726	1	2.5" Hard Drv kit w/ Win98 Cert (compatible only with AMI motherboards)
A10	0950-2782	1	3.5" Disk drive (1.44 MByte)
MP60	54801-60102	1	Chassis assembly (used w/AMI motherboards)
W7	54801-61610	1	Cable - Motherboard floppy port to display board
W8	54801-61625	1	Cable - Display board to floppy drive
W10	54801-61636	1	Cable - Display board to 2.5" HDD
W22	54801-61637	1	Cable - PS/2 mouse connector assy
W23-25	54801-68701	1	AMI motherboard cable kit - serial and parallel cables

**PC Motherboard Configuration 2 (AMI 757 Motherboard w/16 MByte RAM and 1.44 MByte Floppy Drive)(serial prefix range US3805 through US3838 with rear-panel label VIN # 020)<sup>1</sup>**

A4	54810-66512	1	PC Motherboard AMI Series 757 REV C (Atlas PCI-III)
A4A1	1821-3848	1	Microprocessor - AMD-K6/200MHz
A4A2-3	1818-6172	2	DRAM-SIMM 2MX32 (8 MB SIMM)
A4A4	0950-2794	1	Voltage Regulator Module (VRM) 2.9 V
A9	54810-68726	1	2.5" Hard Drv kit w/ Win98 Cert (compatible only w/AMI motherboards)
A10	0950-2782	1	3.5" Floppy Disk Drive - 1.44 MByte
A15	0950-2064	1	Ethernet Adapter Card - ISA
MP60	54801-60102	1	Chassis assembly (compatible only w/AMI motherboard configurations)
W7	54801-61610	1	Cable - Motherboard floppy port to display board
W8	54801-61625	1	Cable - Display board to floppy drive
W10	54801-61636	1	Cable - Display board to 2.5" HDD
W22	54801-61637	1	Cable - PS/2 mouse connector assy
W23-25	54801-68701	1	AMI motherboard cable kit - serial and parallel cables

**PC Motherboard Configuration 3 (AMI Motherboard w/64 MByte RAM and 1.44 MB Floppy Drive)(serial prefix range US3845 through US3909 with rear-panel label VIN # 025)<sup>1</sup>**

A4	54810-66524	1	PC Motherboard AMI Series 757 REV D (Atlas PCI-III)
A4A1	1821-4976	1	Microprocessor - AMD-K6-2/300MHz
A4A2-3	1818-7682	2	DRAM-SIMM 8MX32 (32 MB SIMM)
A4A4	0950-3399	1	Voltage Regulator Module (VRM) 2.2 V
A9	54810-68726	1	2.5" Hard Drv kit w/ Win98 Cert (compatible only w/AMI motherboards)
A10	0950-2782	1	3.5" Floppy Disk Drive - 1.44 MByte
A15	0950-2064	1	Ethernet Adapter Card - ISA
MP60	54801-60102	1	Chassis assembly (compatible only w/AMI motherboard configurations)
W7	54801-61610	1	Cable - Motherboard floppy port to display board
W8	54801-61625	1	Cable - Display board to floppy drive
W10	54801-61636	1	Cable - Display board to 2.5" HDD
W22	54801-61637	1	Cable - PS/2 mouse connector assy
W23-25	54801-68701	1	AMI motherboard cable kit - serial and parallel cables

1. If the PC motherboard was replaced with a newer type, please be sure to use the new BIOS setup procedure and jumper settings that apply to that PC motherboard configuration.

Chapter 7: Replaceable Parts  
**Replaceable Parts List**

---

**Replaceable Parts**

---

<b>Ref. Des.</b>	<b>Agilent Part Number</b>	<b>QTY</b>	<b>Description</b>
<b>PC Motherboard Configuration 4 (AMI Motherboard w/120 MByte Floppy Drive)(serial prefix range US3919 through US3935 with rear-panel label VIN # 025)</b>			
A4	54810-66524	1	PC Motherboard AMI Series 757 REV D (Atlas PCI-III)
A4A1	1821-4976	1	Microprocessor - AMD-K6-2/300MHz
A4A2-3	1818-7682	2	DRAM-SIMM 8MX32 (32 MB SIMM)
A4A4	0950-3399	1	Voltage Regulator Module (VRM) 2.2 V
A9	54810-68726	1	2.5" Hard Drv kit w/ Win98 Cert (compatible only w/AMI motherboards)
A10	0950-3931	1	3.5" LS-120 Floppy Disk Drive - 120 MByte
A15	0950-2064	1	Ethernet Adapter Card - ISA
A18	54810-66530	1	Adapter board w/ 2 connectors - 120 MB drive to ribbon cable
A19	1150-2091	1	Sound card - 16-bit ISA (Option 200 only)
MP60	54801-60102	1	Chassis assembly (compatible only w/AMI motherboard configurations)
W7	not used		
W8	not used		
W10	54801-61641	1	Cable - Display board to 120 MB floppy to 2.5" HDD
W22	54801-61637	1	Cable - PS/2 mouse connector assy
W23-25	54801-68701	1	AMI motherboard cable kit - serial and parallel cables
<b>PC Motherboard Configuration 5 (FIC Motherboard w/120 MByte Floppy Drive)(serial prefix range US3949 and above with rear-panel label VIN # 03X)<sup>2</sup></b>			
A4	54810-66534	1	PC Motherboard FIC VA-503A
A4A1	1821-4776	1	Microprocessor - AMD-K6-2/400MHz
A4A2	1818-8073	1	DRAM-DIMM 16MX32 (64 MB DIMM)
A9	54810-83520	1	2.5" Hard Drv w/ software installed (compatible only w/FIC motherboard configuration)
A10	0950-3931	1	3.5" LS-120 Floppy Disk Drive - 120 MByte
A15	1150-2110	1	Ethernet Adapter Card - PCI 10/100Base-T
A18	54810-66531	1	Adapter board w/ 4 connectors - 120 MB drive to ribbon cables
A19	54810-66533	1	Sound riser card (for FIC motherboard configuration only)
MP60	54801-60103	1	Chassis assembly (compatible w/FIC motherboard configuration)
W7	not used		
W8	not used		
W10	54801-61643	1	Cable - A18 adapter board to 2.5" HDD
W22-25	54801-68706	1	FIC motherboard cable kit (serial, parallel, and PS/2 mouse cables)
W27	54801-61644	1	USB cable assy

2. Option 8ZE, remanufactured unit, may be an older configuration than indicated by the serial prefix number. Refer to the rear-panel VIN # label, floppy drive and BIOS screen to determine the configuration.



---

**Replaceable Parts**

---

<b>Ref. Des.</b>	<b>Agilent Part Number</b>	<b>QTY</b>	<b>Description</b>
<b>All Configurations</b>			
A5	54810-66525	1	DISPLAY BOARD
A6	54801-68703	1	SCOPE INTERFACE BOARD KIT (includes W11 and 54810-66523 or newer pc board)
A7	54810-66504	1	FRONT-PANEL KEYBOARD (2CH) 54810A / 54820A
A7	54815-66504	1	FRONT-PANEL KEYBOARD (4-CH) 54815A / 54825A / 54845A
A8	54810-66507	1	KEYBOARD - CURSOR
A9	See PC Motherboard Configurations earlier in this table.		
A10	See PC Motherboard Configurations earlier in this table.		
A11	54810-66506	1	AUTOPROBE CONTROL BOARD
A13	54810-66527	1	2-CH ACQ. BD.(1Gs) 54810A W/ATTENUATORS AND A/D FISOS
A13	54815-66527	1	4-CH ACQ. BD.(1Gs) 54815A W/ATTENUATORS AND A/D FISOS
A13	54820-66527	1	2-CH ACQ. BD.(2Gs) 54820A W/ATTENUATORS AND A/D FISOS
A13	54825-66527	1	4-CH ACQ. BD.(2Gs) 54825A W/ATTENUATORS AND A/D FISOS
A14	E2073-66701	1	GPIB INTERFACE (82341C)
A15	See PC Motherboard Configurations earlier in this table.		
A16	54810-66511	1	AUTOPROBE INTERFACE BOARD (part of A17 new style)
A17	54820-68701	1	PROBE I/O ASSEMBLY, older style - 2 channel (Used on 54810A/54820A)
A17	54825-68701	1	PROBE I/O ASSEMBLY, older style - 4 channel (Used on 54815A/54825A) Older style A17 probe I/O assemblies consist of MP16, MP54, and W13
A17	54820-68702	1	PROBE I/O ASSEMBLY, new style - 2 channel (Used on 54810A/54820A)
A17	54825-68702	1	PROBE I/O ASSEMBLY, new style - 4 channel (Used on 54815A/54825A) New style A17 probe I/O assemblies consist of A16, H30, MP16, MP69, and W13
A18	See PC Motherboard Configurations earlier in this table.		
A19	See PC Motherboard Configurations earlier in this table.		
<b>Attenuator Assemblies And A/D Hybrids (P/O Acquisition Board)</b>			
A13A1- A13A4	54512-63402	2/4	ATTENUATOR ASSY
A13A5- A13A8	1NB7-8353	2/4	A/D CONVERTER HYBRID
A13E1	54542-67601	2/4	CONNECTOR ASSEMBLY
A13H1	0515-0365	4/8	MS M2X0.4 4MM-LG PANHD T6
A13H2	0515-1908	4/8	MS M2X0.4 16MM-LG PANHD T6
A13H3	0515-2363	4/8	MS M2X0.4 8MM-LG FLATHD T6
A13MP1	54542-09101	2/4	HEAT SINK SPRING
A13MP2	54542-21101	2/4	HEAT SINK
A13MP3	54542-22401	2/4	HEATSINK STANDOFF
A13MP4	54542-04102	2/4	TOP PLATE
A13MP5	54542-04101	2/4	BOTTOM PLATE
<b>Fans</b>			
B1	3160-1013	1	FAN- 12V- 120mm
B2	54810-68501	1	CPU HEATSINK W/FAN
<b>Internal Chassis Parts</b>			
H1	0361-1823	4	FASTENER-PLASTIC PUSH
H2	0515-0372	29	MS M3X0.5 8MM-LG T10
H3	0515-0383	4	MS M4X0.7 16MM-LG PAN-HD T10
H4	0515-0430	8	MS M3 6MM-LG PAN-HD T10
H5	0515-0433	5	MS M4X0.7 8MM-LG PAN-HD T15

Chapter 7: Replaceable Parts  
**Replaceable Parts List**

---

**Replaceable Parts**

---

<b>Ref. Des.</b>	<b>Agilent Part Number</b>	<b>QTY</b>	<b>Description</b>
H6	0515-0680	6	MS 3.0 6 PH T10
H7	0515-1025	4	MS M3X0.5 26MM-LG PAN-HD T10
H8	0515-1403	4	M4X.7 6MM 90DEG FLAT-HD T15
H9	0515-1410	6	MS 3.0 X 0.50 20MM-LG PAN-HD T10
H10	0515-2195	4	MS M4 X 0.7 40MM-LG T15
H11	0515-2691	2	MS M2.6X0.45 6MM-LG PAN-HD T8
H12	0624-0633	7	SCREW-TGP 6-20 T15
H13	2190-0019	2	WHL.115 .226 .03
H14	2190-0027	1	WIL.256 .478 .02
H15	2190-0068	1	WIL.505 .630 .02
H17	2950-0054	1	NUTH 1/2-28 .125
H18	2950-0072	1	NUTH 1/4-32 .062
H19	54801-24702	2	RETAINER-STRAP HANDLE
H20	54542-26101	1	GROUND LUG
H21	54503-25701	5	HEX NUT - FRONT PANEL BNC
H22	0515-1246	2	MS M3X0.5 6MM-LG PATCH LOCK T10
H23	0403-1052	1	STANDOFF/GUIDE - PC BRD
H24	0515-1763	2	SCR-THD-RLG M2x0.4 5MM-LG PAN-HD
H25	8160-1212	1	KEYBOARD GROUNDING SPRING
H26	5021-4302	4	M4x0.7 20MM-LG PAN-HD PATCHLOCK BLACK
H27	1401-0202	2	PROTECTOR CAP .234 ID .3125 DEPTH
H28	0515-1038	2	M3X.05MM 35 MM LG PANHD
H29	0380-1407	2	SPACER M3X25 MM
H30	0515-2219	3	MS 2.5X0.45 5 MM-LG FLAT-HD
MP37	1400-2120	2	ISA SLOT COVER
MP49	54801-00201	1	FRONT PANEL
MP50	54801-01205	1	LENS BRACKET
MP51	54801-01206	1	BRACKET-CAL BNC
MP52	54801-01702	1	SLEEVE, CABINET (1 FAN)
MP53	54801-04104	1	FRONT PANEL ASSY INSIDE COVER
MP54	54801-04102	1	AUTOPROBE PANEL (Older style)
MP54	54801-24701	1	AUTOPROBE PANEL (New style)
MP55	54801-04103	1	KEYBOARD CONNECTOR PLATE
MP56	54801-40502	1	FRONT FRAME
MP57	54801-01208	1	HARD DRIVE BRACKET-2.5" HD
MP60	See PC Motherboard Configurations earlier in this table.		
MP61	54801-88001	1	LENS
MP62	54810-41901	1	FRONT-PANEL KEYPAD-MAIN (2 CH)
MP63	54815-41901	1	FRONT-PANEL KEYPAD-MAIN (4-CH) (54815A / 54825A)
MP64	54810-41902	1	KEYPAD-CURSOR
MP69	54801-09101	2	AUTOPROBE PNL SNAP-IN CLIPS
MP73	54815-85401	0	INSULATOR - 120 MB Floppy drive (only on upgraded units)
MP74	54810-01210	0	BRACKET-ADAPTER BOARD (only on upgraded units)
MP75	0403-1091	1	Bumper - self adhesive
<b>Cables</b>			
W2	54801-61605	1	CBL ASSY-POWER SUPPLY CONTROL
W3	54801-61603	1	CBL ASSY-5V POWER
W4	54801-61604	1	CBL ASSY-AUX.POWER
W5	54801-61607	1	CBL ASSY-PC POWER
W6	54801-61601	1	CBL ASSY-LINE SYNC

---

**Replaceable Parts**

---

<b>Ref. Des.</b>	<b>Agilent Part Number</b>	<b>QTY</b>	<b>Description</b>
W7	See PC Motherboard Configurations earlier in this table.		
W8	See PC Motherboard Configurations earlier in this table.		
W9	See PC Motherboard Configurations earlier in this table.		
W10	See PC Motherboard Configurations earlier in this table.		
W11	54801-61612	1	ACQUISITION CABLE (w/ AMP-LATCH(r) connector on each end. Used with Scope Interface board p/n 54810-66503 and below)
W11	54801-61640	1	ACQUISITION CABLE (w/ AMP-LATCH(r) connector on one end & Tripolarized connector on other end. Used with Scope Interface board p/n 54810-66523 and above)
W12	54801-61622	1	PROBE POWER & CONTROL CABLE
W13	54801-61623	1	FLEX CIRCUIT, PROBE INTERFACE (Older style)
W13	54801-61642	1	CABLE - AUTOPROBE INTERFACE TO AUTOPROBE BOARD (New style)
W14	54801-61624	1	DISPLAY BD. JUMPER
W15	54801-61626	1	KEYBOARD INTERCONNECT
W16	54801-61628	1	KEYBOARD CABLE
W17	54801-61635	1	BACKLIGHT CABLE
W18	54801-61638	1	CABLE - 50 Ω
W19	54801-61634	1	PROBE COMP CABLE
W20	54801-61609	1	DISPLAY CABLE
W21	54801-61613	1	FAN CABLE
W22	See PC Motherboard Configurations earlier in this table.		
W23	See PC Motherboard Configurations earlier in this table.		
W24/25	See PC Motherboard Configurations earlier in this table.		
W26	Not used on 54810A/15A/20A/25A.		
W27	See PC Motherboard Configurations earlier in this table.		



Block-Level Theory 8-3  
  Power Supply Assembly 8-3  
  FPD Monitor Assembly 8-3  
  Acquisition System 8-4  
  Front Panel 8-4  
  Disk Drives 8-4  
  Attenuators 8-4  
  Motherboard 8-4  
  SVGA Display Card 8-5  
  GPIB Interface Card 8-5  
  Probe Power and Control 8-5  
Attenuator and Preamp Theory 8-7  
Acquisition Theory 8-7  
  Acquisition Board 8-7  
  Scope Interface Board 8-9

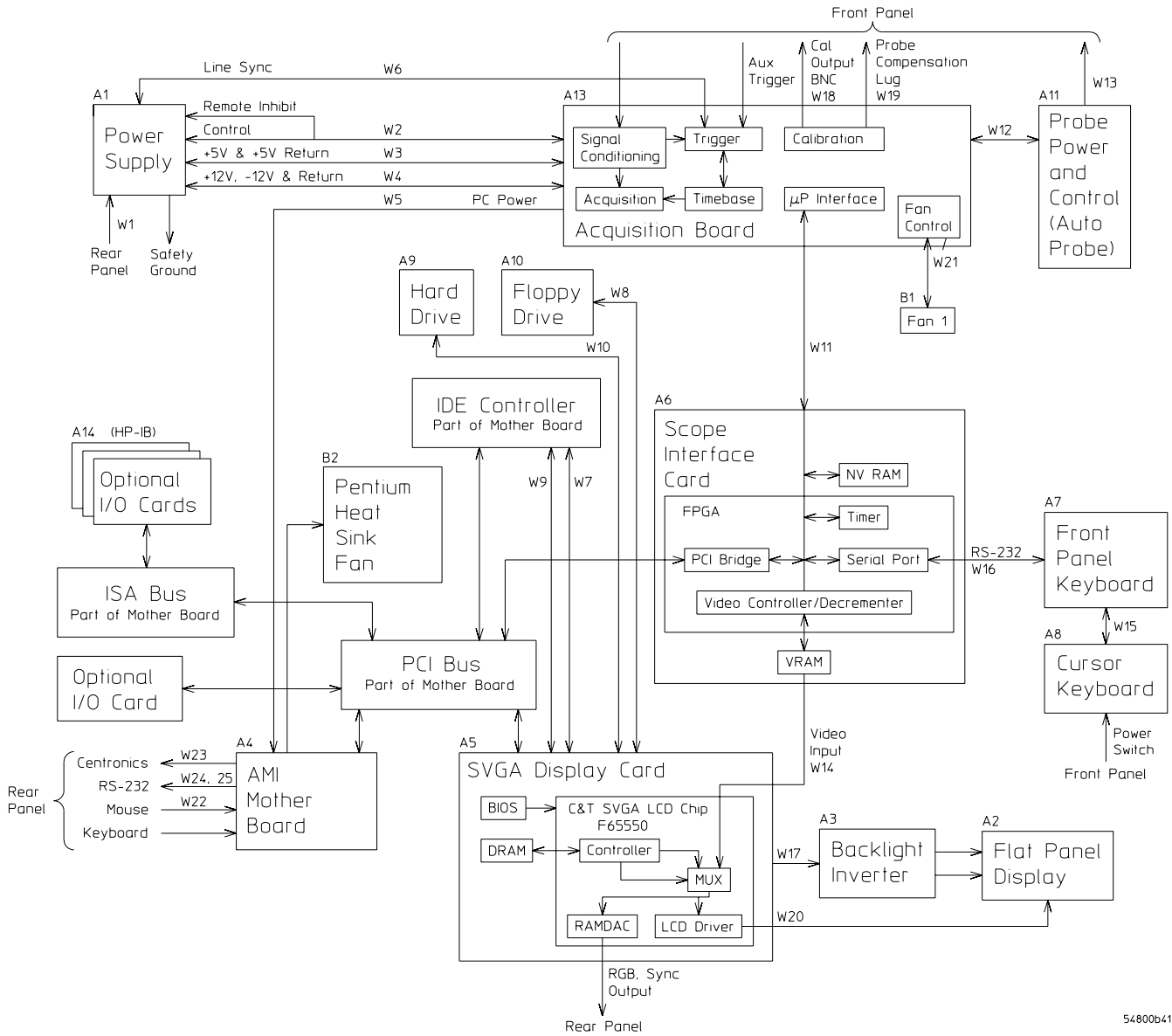

54800b41

Instrument Block Diagram Shown For Original Configuration w/ 1.44 MB Floppy Drive

---

# Theory of Operation

This *Service Guide* supports troubleshooting to assembly level. Theory of operation is included only as supplemental information. It is not comprehensive enough for component-level troubleshooting. The main body of following theory describes the Agilent Technologies 54825A. Differences in the other family models are covered at the end of the acquisition section.

---

## Block-Level Theory

The Agilent Technologies 54825A Oscilloscope has four channels which are individually sampled at 2 GSa/s. Each channel is stored into 32 Kbytes of memory. The other instruments in this family have reduced specifications or features. The front panel provides:

- Dedicated knobs and pushbuttons for major oscilloscope functions.
- An 8.4-inch (diagonal) color flat panel display for waveform, measurement, and graphical interface display.
- A 3 1/2-inch flexible disk drive.
- BNC connectors for channel input signals, auxiliary trigger input, and auxiliary output.
- AutoProbe interface for probe power and probe control.
- A connection for probe compensation.

The rear panel provides several connections:

- The line power input.
- An GPIB connector, for connection to an instrument controller.
- An RS-232 connection.
- A parallel printer connection.
- VGA monitor connection.
- Mouse and keyboard connections.

The instrument has several assemblies and four attenuators. Use the instrument block diagram on the previous page for the following discussion.

### **Power Supply Assembly**

The switching power supply provides 300 W maximum for the instrument. The ac input to the power supply is 100–240 Vac, +/-10%. Maximum input power is 390W. The ac input frequency is 47 to 440 Hz.

Filtered voltages of +5.1 V, -5.3 V, +12.2 V, and -12.2 V are supplied to the acquisition board, where they are distributed throughout the board and to other assemblies.

### **FPD Monitor Assembly**

The monitor is a thin film liquid-crystal display (TFT-LCD). This FPD is an 8.4-inch diagonal, 640 by 480 pixel VGA Color Monitor. The assembly requires +3.3 V and +12 V from the power supply.

A twin fluorescent back light provides illumination for the LCD. The Backlight Inverter assembly converts the +12 V to +300-1000 volts (acrms) and drives the back light.

### **Acquisition System**

The acquisition system includes the attenuator assemblies, acquisition board, and scope interface board. The attenuators and acquisition preamps condition the signal, which is then digitized and stored by the acquisition board. The scope interface board provides the system control interface from the motherboard, and also interfaces the acquisition board to the SVGA display board for display of the acquired data. More detailed theory on the acquisition system follows this top-level block theory.

### **Front Panel**

The front panel is read and controlled by a microcontroller IC. This device contains a microprocessor, RAM, ROM, and a DUART for communication with the microprocessor on the main assembly. The microcontroller is located on the keyboard and communicates with the system control circuitry through a cable and RS-232 interface. It reads the keys and knobs and controls the LED indicators.

The elastomeric keypad has 30 keys, all dedicated to a single function to improve ease of use. A conductive element on the inside of each key closes a gap on the underlying keyboard circuit. The keyboard controller detects this short and sends the proper keypress information to the system controller on the motherboard.

There are eleven dedicated knobs. Each knob controls a mechanical switch. The output of the switch is a 2-bit gray code that is read by the microcontroller for direction and distance turned. A pushbutton controls the power through a Remote Inhibit sense line that is routed to the power supply. When closed, there is an impedance of approximately  $196\ \Omega$  to ground from the Remote Inhibit sense line; the power supply detects this and turns on or off as required.

### **Disk Drives**

The flexible disk drive is 1.44 Mbyte, MS-DOS compatible. It is located on the front panel. The disk drive can be used to load a new oscilloscope operating system or to load application-specific software. This disk drive is only available on older Infinium oscilloscopes.

The LS-120 flexible disk drive is 120 Mbyte, MS-DOS compatible. It is located on the front panel. The disk drive can be used to load a new oscilloscope operating system or to load application-specific software. This disk drive is available on newer Infinium oscilloscopes or those Infinium oscilloscopes that have been upgraded.

The hard disk drive is a 2.5" high-capacity, shock-resistant unit. It is used to store the oscilloscope operating system and certain system configuration data.

Either drive can also be used to store and recall instrument setups and waveforms.

### **Attenuators**

The attenuators provide the appropriate impedance matching and all the attenuation and gain changing for each input channel. They connect directly to the main assembly and are fastened to the main assembly with screws.

### **Motherboard**

The motherboard provides all system control and interface functions for the instrument. It contains a CPU, ROM, RAM, keyboard and mouse interfaces, serial and parallel interfaces, hard and floppy disk drive interfaces, and interfaces to the IBM-PC industry compatible ISA (Industry Standard Architecture) and PCI (Peripheral Component Interconnect) buses.



### **SVGA Display Card**

The SVGA Display Card controls the flat-panel display monitor. There are two major video paths on this board. The first is used by the system controller on the motherboard to draw all general display elements, including the grid, status indicators, and toolbars and menus for the graphical interface. This is handled through a standard VGA chip, BIOS, and DRAM, similar to a standard PC VGA interface. The other path is the video input from the scope interface board, which is multiplexed with the main video to produce the video signals for the flat-panel display. The video from the scope interface board is the waveform display data. The second path is used to provide the fastest possible display update rate, which would not be possible through the standard bus interface to the display controller.

### **GPIB Interface Card**

The GPIB Interface card provides IEEE-488.2 standard bus services for the oscilloscope. The card interfaces the bus to the motherboard system controller, allowing the system controller to receive and process GPIB commands and return data to the bus. The circuit consists of three main components. The GPIB controller provides an interface between the microprocessor system and the GPIB in accordance with IEEE 488 standards. An 8-bit data buffer and 8-bit control line buffer connect the GPIB controller to the GPIB bus. The GPIB is a 24-conductor shielded cable carrying 8 data lines, 8 control lines, 7 system grounds, and 1 chassis ground.

### **Probe Power and Control**

The Probe Power and Control board provides filtered, regulated power to the front-panel AutoProbe interface. It also provides serial communications capability, offset and probe detection and identification circuitry. All of these are interfaced to the probe through the conductive pads surrounding the BNCs. Using the facilities of this board, the Autoprobe interface can supply power for active probes, notify the oscilloscope operating system when a probe is connected or disconnected, identify the probe type to the oscilloscope operating system for automatic configuration, and communicate with the probe to support advanced probe functionality.

Chapter 8: Theory of Operation  
**Block-Level Theory**

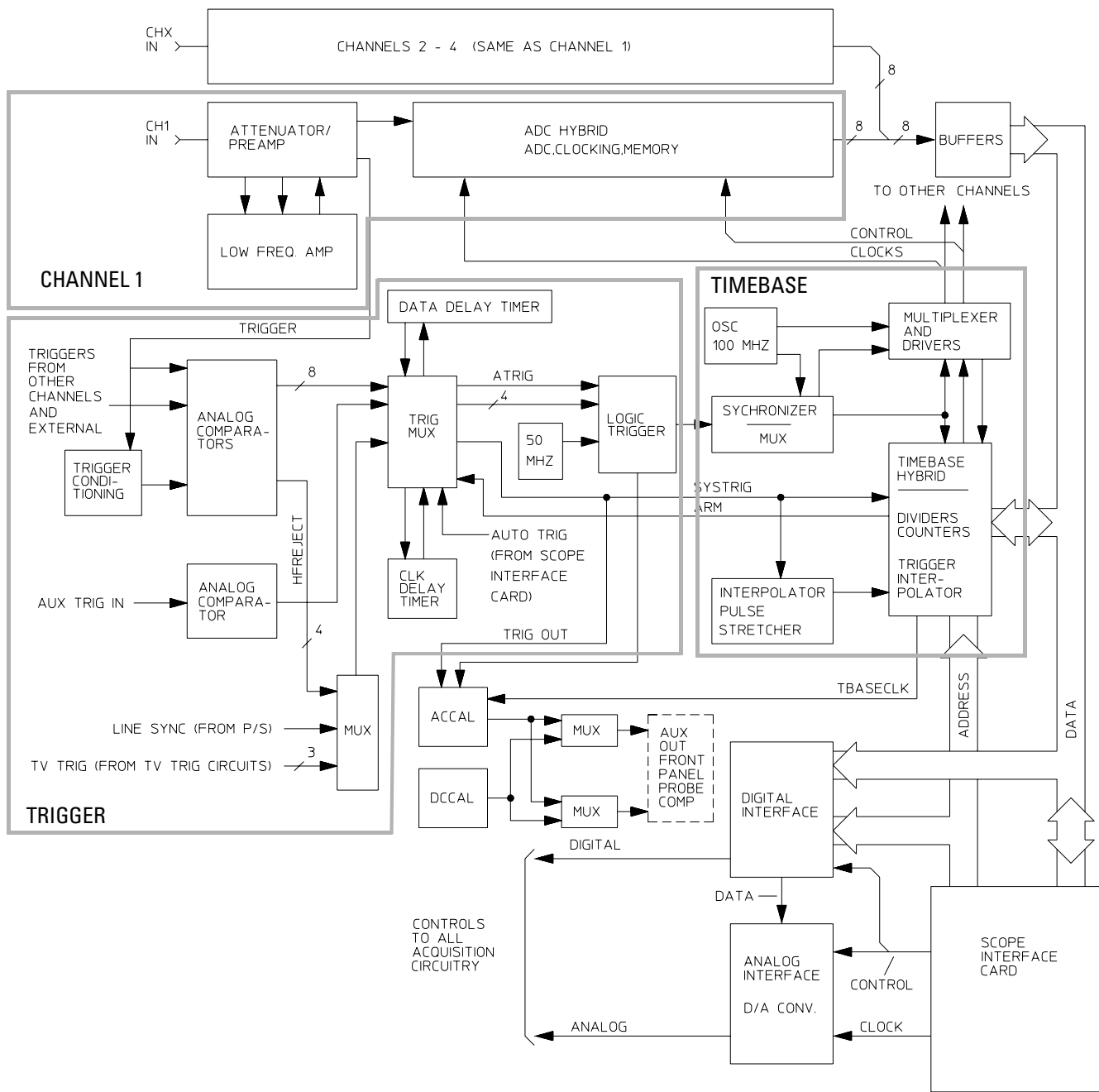

54800b54

**Acquisition Block Diagram**

---

## Attenuator and Preamp Theory

The channel input signals are conditioned by the attenuator/preamps, thick film hybrids containing passive attenuators, an impedance converter, and a programmable amplifier. The channel sensitivity, as displayed, defaults to the standard 1-2-5 sequence (other calibrated sensitivities can also be set). However, the firmware uses two passive attenuators, 5:1 and 25:1, to get attenuations of 1:1, 5:1, 25:1, and 125:1. With the attenuation and programmable gain of the amplifier the entire sensitivity range is calibrated. (On ranges below 7 mV/div, the firmware expands the signal digitally.)

The input has a selectable 1 M $\Omega$  or 50  $\Omega$  input impedance. Compensation for the passive attenuators is laser trimmed and not adjustable. After the passive attenuators, the signal is split into high-frequency and low-frequency components. Low-frequency components are amplified on the main assembly where they are combined with the offset voltage. The ac coupling is implemented in the low-frequency amplifier.

The high- and low-frequency components of the signal are recombined and applied to the input FET of the preamp. The FET provides a high impedance load for the input attenuators and a low impedance drive for the preamp. The programmable preamp adjusts the gain to suit the required sensitivity and provides two output signals to the Main assembly. One signal is the same phase as the input and goes to the trigger circuitry. The other is of opposite phase and is sent to the ADC hybrid.

---

## Acquisition Theory

The acquisition system includes two major sections. One is the acquisition board, which conditions, stores, and processes the input signals. The other is the scope interface board, which provides the interface from the acquisition to the motherboard and display, and also interfaces the motherboard to the front-panel keyboard.

### Acquisition Board

The acquisition circuitry samples, digitizes, and stores the signals from the channel attenuators. The four channels are identical. The trigger signals synchronize acquisition through the trigger and time base circuitry. A 100-MHz oscillator and the time base provide the base sample rates.

**ADC Hybrid** The ADC hybrid provides all of the sampling, digitizing, and high-speed waveform storage. The ADC includes a phase-locked loop frequency converter that, for sample rates from 250 MHz to 2 GHz, multiplies the input clock from the time base.

**Trigger** There are four main trigger circuits: Trigger Conditioning, Analog Comparators, a Trigger Multiplexer, and Logic Trigger. Trigger signals from the channel and the external trigger attenuators are fed to the analog trigger comparators and the trigger conditioning circuit. The trigger conditioning circuitry selects dc, ac, low-frequency reject, high-frequency reject, and noise reject (hysteresis) modes and sets the trigger levels. The trigger multiplexer selects the trigger modes, such as edge, glitch, and pattern trigger.

The channel triggers are sent to the Logic Trigger. The logic trigger provides the advanced triggering functions, such as holdoff, delay, and pattern duration and range. The data delay and clock delay timers are used to implement trigger functions that require timing between 1.5 and 20 ns.

The auxiliary trigger, which cannot be displayed on screen, is compared to the trigger level setting in a separate circuit. The line sync trigger line from the power supply is combined in a multiplexer with the TV trigger and the high frequency reject comparators before being sent to the analog trigger.

**Time Base** The time base provides the sample clocks and timing necessary for data acquisition. It primarily consists of the 100-MHz reference oscillator, time base IC, and trigger interpolator pulse stretcher.

- The 100-MHz reference oscillator provides the base sample frequency.
- The time base has programmable dividers to provide the rest of the sample frequencies appropriate for the time range selected. The time base uses the time-stretched output of the interpolator pulse stretcher to time-reference the sampling to the trigger point. The time base has counters to control how much data is taken after the trigger event (post-trigger data). After enough pre-trigger samples have occurred, the time base IC sends a signal to the trigger multiplexer (ARM) indicating it is ready for the trigger event. When the trigger condition is satisfied, the trigger multiplexer sends a signal back to the time base (SYSTRIG). The time base IC then starts the post-trigger delay counter. When the countdown reaches zero, the sample clocks are stopped and the CPU is signaled that the acquisition is complete.
- The Interpolator Pulse Stretcher is a dual-slope integrator that acts as a time-interval stretcher. When the logic trigger receives a signal that meets the programmed triggering requirements (SYSTRIG), it signals the time base. The time base then sends a pulse to the pulse stretcher. The pulse is equal in width to the time between the trigger (SYSTRIG) and the next sample clock. The pulse stretcher stretches this time by a factor of approximately 1000. Meanwhile, the time base hybrid runs a counter with a clock derived from the sample rate oscillator. When the interpolator indicates the stretch is complete, the counter is stopped. The count represents, with high accuracy, the time between the trigger and the first sample clock. The count is stored and used to place the recently acquired data in relationship to the trigger point.

**Calibration** The Calibration circuit provides several signals to the Probe Compensation and Aux Out outputs. Which signal is driven to the front panel depends on the current selection from the drop-down menu in the Calibration dialog box. Available signals for Aux Out include a 715 Hz probe compensation signal, a pulse representing the trigger event, the timebase clock, or a dc voltage in the range -2.5 to +2.5 V. The dc Cal DAC is used for self-calibration, and is an output from a 16-channel DAC. The calibration signals are sent to an analog multiplexer, which selects the signal that will be sent to the front panel.

**Microprocessor Interface** The Microprocessor Interface provides control and interface between the system control and digital functions in the acquisition circuitry.

**Analog Interface** The Analog Interface provides analog control of functions in the acquisition circuitry. It is primarily a 16-channel DAC with an accurate reference and filtered outputs. The analog interface controls:

- Channel offsets
- Trigger levels
- Two logic trigger functions
- Board temperature

**Family Acquisition Differences** The following explains the differences in the three models that comprise the rest of this family, the Agilent Technologies 54815A, 54820A, and 54810A.

- The Agilent 54815A oscilloscope has four channels like the Agilent 54825A, except that its maximum sample rate is 1 GSa/s. The acquisition architecture is otherwise identical to the Agilent 54825A.
- The Agilent 54820A has the sample rate capability of the Agilent 54825A, 2 GSa/s, but only two signal channels. The third channel position is unused and the fourth channel position is used for an External Trigger. The external trigger uses an attenuator/preamp for signal conditioning and has some of the ranging capability of a channel but no acquisition circuitry (there is no ADC hybrid). The output of the external trigger attenuator/preamp is fed to the analog trigger just like a channel. There is no Aux Trig input.
- The Agilent 54810A has the two-channel configuration of the Agilent 54820A with a 1 GSa/s maximum sample rate.

### Scope Interface Board

The Scope Interface Board has three primary functions:

- Interface the acquisition board to the motherboard system controller.
- Manage the waveform display, through an interface to the SVGA display board.
- Implement miscellaneous oscilloscope functions, including an RS-232 interface to the front-panel keyboard, a 32-bit timer, and non-volatile RAM.

**Acquisition Board Interface** The interface to the acquisition board consists of 16 data lines, 10 address lines, a R/W line, and read and write strobes. A second read strobe is used for reading acquisition data; the address latches are not used when this strobe is active. Three lines are used to indicate run, trigger, and interpolator status; two control lines are used for trigger control and clocking.

There are two address ranges on the acquisition board; the first is used for reading acquisition data, while the second is used to access status and control elements of the board.

**Waveform Display Management** A PC video connector connects the scope interface board to the SVGA display board. The scope interface board accepts video clock and synchronization signals from the SVGA display board, and drives 16 bits of RGB data in 5,6,5 format to the display controller on the SVGA display board. The display driver will only substitute the PC video RGB data from the scope interface card for the other video data when the screen data matches the value specified in the display driver. In this way, the scope interface card can supply the waveform data from the acquisition system and have it properly multiplexed with regular video data for output on the flat-panel display.

**Miscellaneous System Functions** An RS-232 interface is used to communicate with the front panel keyboard. The connector routes transmit and receive, power supply bias and inhibit signals, and keyboard power to the keyboard. The interface functionality is contained in the FPGA. The data rate is 19.2 KBaud, with 1 start bit, 8 data bits (LSB first), and one stop bit, no parity. The keyboard itself has a controller that transmits and receives data through this interface.

Non-Volatile RAM (NVRAM) on the scope interface board provides high-speed access to instrument configuration settings.



# DECLARATION OF CONFORMITY

according to ISO/IEC Guide 22 and EN 45014

**Manufacturer's Name:** Agilent Technologies  
**Manufacturer's Address:** Colorado Springs Division  
1900 Garden of the Gods Road  
Colorado Springs, CO 80907 USA

declares, that the product

**Product Name:** Infiniium Oscilloscope

**Model Number(s):** Agilent 54810A, 54815A, 54820A, 54825A

**Product Option(s):** All

conforms to the following Product Specifications:

**Safety:** IEC 1010-1:1990+A1 / EN 61010-1:1993

UL 3111

CSA-C22.2 No. 1010.1:1993

**EMC:** CISPR 11:1990 / EN 55011:1991 Group 1 Class A

IEC 555-2:1982 + A1:1985 / EN 60555-2:1987

IEC 555-3:1982 + A1:1990 / EN 60555-3:1987 + A1:1991

IEC 801-2:1991 / EN 50082-1:1992 4 kV CD, 8 kV AD

IEC 801-3:1984 / EN 50082-1:1992 3 V/m, {1kHz 80% AM, 27-1000 MHz}

IEC 801-4:1988 / EN 50082-1:1992 0.5 kV Sig. Lines, 1 kV Power Lines

## Supplementary Information:

The product herewith complies with the requirements of the Low Voltage Directive 73/23/EEC and the EMC Directive 89/336/EEC and carries the CE marking accordingly.

This product was tested in a typical configuration with Agilent Technologies test systems.

Colorado Springs, 03/04/97

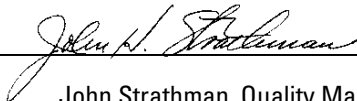
  
John Strathman, Quality Manager

European Contact: Your local Agilent Technologies Sales and Service Office or Agilent Technologies GmbH, Department ZQ / Standards Europe, Herrenberger Strasse 130, D-71034 Böblingen Germany (FAX: +49-7031-14-3143)

## Product Regulations

**Safety** IEC 1010-1:1990+A1 / EN 61010-1:1993  
UL 3111  
CSA-C22.2 No.1010.1:1993

**EMC** This Product meets the requirement of the European Communities (EC)  
EMC Directive 89/336/EEC.



**Emissions** EN55011/CISPR 11 (ISM, Group 1, Class A equipment)

**Immunity** EN50082-1

	Code <sup>1</sup>	Notes <sup>2</sup>
--	-------------------	--------------------

IEC 555-2	1	
IEC 555-3	1	
IEC 801-2 (ESD) 8kV AD	2	
IEC 801-3 (Rad.) 3 V/m	2	
IEC 801-4 (EFT) 0.5 kV, 1kV	1,2	

<sup>1</sup> Performance Codes:

1 PASS - Normal operation, no effect.

2 PASS - Temporary degradation, self recoverable.

3 PASS - Temporary degradation, operator intervention required.

4 FAIL - Not recoverable, component damage.

<sup>2</sup> Notes:

**Sound Pressure Level** Less than 60 dBA



Reproduction, adaptation, or translation without prior written permission is prohibited, except as allowed under the copyright laws.

#### Restricted Rights Legend.

Use, duplication or disclosure by the U.S. Government is subject to restrictions as set forth in subparagraph (c) (1) (ii) of the Rights in Technical Data and Computer Software clause at DFARS 252.227-7013 for DOD agencies, and subparagraphs (c) (1) and (c) (2) of the Commercial Computer Software Restricted Rights clause at FAR 52.227-19 for other agencies.

Agilent Technologies  
3000 Hanover Street  
Palo Alto, California 94304 U.S.A.

#### Document Warranty

The information contained in this document is subject to change without notice.

**Agilent Technologies makes no warranty of any kind with regard to this material, including, but not limited to, the implied warranties of merchantability or fitness for a particular purpose.**

Agilent Technologies shall not be liable for errors contained herein or for damages in connection with the furnishing, performance, or use of this material.

#### Safety

This apparatus has been designed and tested in accordance with IEC Publication 1010, Safety Requirements for Measuring Apparatus, and has been supplied in a safe condition. This is a Safety Class I instrument (provided with terminal for protective earthing). Before applying power, verify that the correct safety precautions are taken (see the following warnings). In addition, note the external markings on the instrument that are described under "Safety Symbols."

#### Warning

- Before turning on the instrument, you must connect the protective earth terminal of the instrument to the protective conductor of the (mains) power cord. The mains plug shall only be inserted in a socket outlet provided with a protective earth contact. You must not negate the protective action by using an extension cord (power cable) without a protective conductor (grounding). Grounding one conductor of a two-conductor outlet is not sufficient protection.
- Only fuses with the required rated current, voltage, and specified type (normal blow, time delay, etc.) should be used. Do not use repaired fuses or short-circuited fuseholders. To do so could cause a shock or fire hazard.
- Service instructions are for trained service personnel. To avoid dangerous electric shock, do not perform any service unless qualified to do so. Do not attempt internal service or adjustment unless another person, capable of rendering first aid and resuscitation, is present.
- If you energize this instrument by an auto transformer (for voltage reduction), make sure the common terminal is connected to the earth terminal of the power source.
- Whenever it is likely that the ground protection is impaired, you must make the instrument inoperative and secure it against any unintended operation.
- Do not operate the instrument in the presence of flammable gasses or fumes. Operation of any electrical instrument in such an environment constitutes a definite safety hazard.
- Do not install substitute parts or perform any unauthorized modification to the instrument.
- Capacitors inside the instrument may retain a charge even if the instrument is disconnected from its source of supply.
- Use caution when exposing or handling the CRT. Handling or replacing the CRT shall be done only by qualified maintenance personnel.

#### Safety Symbols



Instruction manual symbol: the product is marked with this symbol when it is necessary for you to refer to the instruction manual in order to protect against damage to the product.



Hazardous voltage symbol.



Earth terminal symbol: Used to indicate a circuit common connected to grounded chassis.

#### WARNING

The Warning sign denotes a hazard. It calls attention to a procedure, practice, or the like, which, if not correctly performed or adhered to, could result in personal injury. Do not proceed beyond a Warning sign until the indicated conditions are fully understood and met.

#### CAUTION

The Caution sign denotes a hazard. It calls attention to an operating procedure, practice, or the like, which, if not correctly performed or adhered to, could result in damage to or destruction of part or all of the product. Do not proceed beyond a Caution symbol until the indicated conditions are fully understood or met.

---

## Product Warranty

This Agilent Technologies product has a warranty against defects in material and workmanship for a period of three years from date of shipment. During the warranty period, Agilent Technologies will, at its option, either repair or replace products that prove to be defective.

For warranty service or repair, this product must be returned to a service facility designated by Agilent Technologies.

For products returned to Agilent Technologies for warranty service, the Buyer shall prepay shipping charges to Agilent Technologies and Agilent Technologies shall pay shipping charges to return the product to the Buyer. However, the Buyer shall pay all shipping charges, duties, and taxes for products returned to Agilent Technologies from another country.

Agilent Technologies warrants that its software and firmware designated by Agilent Technologies for use with an instrument will execute its programming instructions when properly installed on that instrument. Agilent Technologies does not warrant that the operation of the instrument software, or firmware will be uninterrupted or error free.

## Limitation of Warranty

The foregoing warranty shall not apply to defects resulting from improper or inadequate maintenance by the Buyer, Buyer-supplied software or interfacing, unauthorized modification or misuse, operation outside of the environmental specifications for the product, or improper site preparation or maintenance.

**No other warranty is expressed or implied. Agilent Technologies specifically disclaims the implied warranties of merchantability or fitness for a particular purpose.**

## Exclusive Remedies

The remedies provided herein are the buyer's sole and exclusive remedies. Agilent Technologies shall not be liable for any direct, indirect, special, incidental, or consequential damages, whether based on contract, tort, or any other legal theory.

## Assistance

Product maintenance agreements and other customer assistance agreements are available for Agilent Technologies products.

For any assistance, contact your nearest Agilent Technologies Sales Office.

## Certification

Agilent Technologies certifies that this product met its published specifications at the time of shipment from the factory. Agilent Technologies further certifies that its calibration measurements are traceable to the United States National Institute of Standards and Technology, to the extent allowed by the Institute's calibration facility, and to the calibration facilities of other International Standards Organization members.

## About this edition

This is the *Agilent Technologies Infiniium Oscilloscopes Service Guide for Agilent Models 54810A/15A/20A/25A*.

Publication number  
54810-97067, February 2001  
Printed in USA.

Print history is as follows:  
54810-97003, July 1997  
54810-97013, March 1998  
54810-97027, May 1998  
54810-97028, January 1999  
54810-97032, May 1999  
54810-97044, November 1999  
54810-97057, January 2000  
54810-97067, February 2001

New editions are complete revisions of the manual. Many product updates do not require manual changes; and, conversely, manual corrections may be done without accompanying product changes. Therefore, do not expect a one-to-one correspondence between product updates and manual updates.

Windows is a trademark of Microsoft Corporation.  
Microsoft is a trademark of Microsoft Corporation.  
MS-DOS is a trademark of Microsoft Corporation.  
Intel and Pentium are registered trademarks of Intel Corporation.  
AMD is a registered trademark of Advanced Micro Devices Corporation.  
AMI is a trademark of American Megatrends, Incorporated.