



Advanced Test Equipment Rentals
www.atecorp.com 800-404-ATEC (2832)

Notice

Hewlett-Packard to Agilent Technologies Transition

This documentation supports a product that previously shipped under the Hewlett-Packard company brand name. The brand name has now been changed to Agilent Technologies. The two products are functionally identical, only our name has changed. The document still includes references to Hewlett-Packard products, some of which have been transitioned to Agilent Technologies.

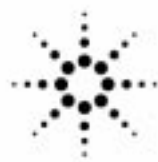

Agilent Technologies

By internet, phone, or fax, get assistance with all your test and measurement needs.

Table 1-1 Contacting Agilent

Online assistance: www.agilent.com/find/assist

United States
(tel) 1 800 452 4844

Latin America
(tel) (305) 269 7500
(fax) (305) 269 7599

Canada
(tel) 1 877 894 4414
(fax) (905) 282-6495

Europe
(tel) (+31) 20 547 2323
(fax) (+31) 20 547 2390

New Zealand
(tel) 0 800 738 378
(fax) (+64) 4 495 8950

Japan
(tel) (+81) 426 56 7832
(fax) (+81) 426 56 7840

Australia
(tel) 1 800 629 485
(fax) (+61) 3 9210 5947

Asia Call Center Numbers

Country	Phone Number	Fax Number
Singapore	1-800-375-8100	(65) 836-0252
Malaysia	1-800-828-848	1-800-801664
Philippines	(632) 8426802 1-800-16510170 (PLDT Subscriber Only)	(632) 8426809 1-800-16510288 (PLDT Subscriber Only)
Thailand	(088) 226-008 (outside Bangkok) (662) 661-3999 (within Bangkok)	(66) 1-661-3714
Hong Kong	800-930-871	(852) 2506 9233
Taiwan	0800-047-866	(886) 2 25456723
People's Republic of China	800-810-0189 (preferred) 10800-650-0021	10800-650-0121
India	1-600-11-2929	000-800-650-1101

Operation and Service Manual

HP 8447D/E/F and HP 8447F H64 Amplifiers

Serial Numbers: HP 8447D, 2944A
HP 8447E, 2944A
HP 8447F, 2944A
HP 8447F H64, 3113A



HP Part No. 08447-90066
Supersedes 08447-90033, 08447-90063, 08447-90059
Printed in USA
Print Date: July 1996

Copyright Hewlett-Packard Company 1970-1996. All Rights Reserved. Reproduction, adaptation, or translation without prior written permission is prohibited, except as allowed under the copyright laws.

1400 Fountaingrove Parkway, Santa Rosa, CA 95403-1799, USA

Legal

The information contained in this document is subject to change without notice. Hewlett-Packard makes no warranty of any kind with regard to this material, including but not limited to, the implied warranties of merchantability and fitness for a particular purpose. Hewlett-Packard shall not be liable for errors contained herein or for incidental or consequential damages in connection with the furnishing, performance, or use of this material.

Safety Info

WARNING: Warning denotes a hazard. It calls attention to a procedure which, if not correctly performed or adhered to, could result in injury or loss of life. Do not proceed beyond a warning note until the indicated conditions are fully understood and met.

WARNING: This is a Safety Class I product (provided with a protective earthing ground incorporated in the power cord). The mains plug shall only be inserted in a socket outlet provided with a protective earth contact. Any interruption of the protective conductor, inside or outside the instrument, is likely to make the instrument dangerous. Intentional interruption is prohibited.

CAUTION: Caution denotes a hazard. It calls attention to a procedure that, if not correctly performed or adhered to, would result in damage to or destruction of the instrument. Do not proceed beyond a caution sign until the indicated conditions are fully understood and met.

CAUTION: This product is designed for use in Installation Category II and Pollution Degree 2.

This instrument has been designed and tested in accordance with IEC Publication 348, Safety Requirements for Electronic Measuring Apparatus, and has been supplied in a safe condition. The instruction documentation contains information and warnings which must be followed by the user to ensure safe operation and to maintain the instrument in a safe condition.

”CSA” The CSA mark is a registered trademark of the Canadian Standards Association.

Notice for Germany: Noise Declaration LpA % < 70 dB am Arbeitsplatz (operator position) normaler Betrieb (normal position) nach DIN 45635 T. 19 (per ISO 7779)

Operation and Service Manual

General Information

The HP 8447D, 8447E and 8447F are general purpose, wideband amplifiers. Each instrument consists of a power supply and one or two thin film, hybrid, integrated circuit amplifiers. The thin film amplifiers are hermetically sealed and feature low noise, low distortion, flat frequency response, and long term stability and reliability.

The HP 8447D Amplifier is a pre-amplifier that provides 25 dB of gain to signals from 100 kHz to 1.3 GHz. It can be used to increase the sensitivity of any lab, shop or field device operating within its frequency range.

The HP 8447E Amplifier is a power amplifier that provides 22 dB of gain to signals from 100 kHz to 1.3 GHz. It can be used to increase the output power of signal generators, swept sources and similar devices operating within its frequency range.

The HP 8447F Amplifier contains a preamplifier and a power amplifier. They are the same thin film amplifiers used in the HP 8447D and HP 8447E. The input and output ports of both amplifiers are available on the front panel. They can be used separately or cascaded to provide 47 dB of gain.

The HP 8447F Option H64 Amplifier is a general purpose wide band amplifier with Type-N connectors. It contains two preamplifiers. One provides 26 dB minimum gain to signals from 9 kHz to 50 MHz. The other provides 25 dB minimum gain to signals from 100 kHz to 1300 MHz.

Table 1 **HP 8447D and HP 8447E Specifications**

Specifications	HP 8447D Preamp	HP 8447E Power Amp
Frequency range	0.1 to 1300 MHz	0.1 to 1300 MHz
Typical 3 dB bandwidth (Std, Opt 001 and Opt 011)	.075 to 1700 MHz	.075 to 1400 MHz
Mean Gain (20° to 30°C)	25 dB minimum	22 dB ± 2.0dB
Gain flatness across frequency range	± 1.5 dB	± 1.5 dB
Noise Figure	<8.5 dB	<11 dB (typical)
Output power for 1 dB gain compression	>+7 dBm (typical)	≥+12.5 dBm (0.1 to 1000 MHz)

Table 1 HP 8447D and HP 8447E Specifications

Specifications	HP 8447D Preamp	HP 8447E Power Amp
Harmonic distortion	-30 dB for 0 dBm output (typical)	-30 dB for +8 dBm output
Typical output for <-60 dB harmonic distortion	-30 dBm	-20 dBm
VSWR, 1 to 1300 MHz	<2.0:1 Input <2.2:1 Output	—
VSWR, 1 to 1400 MHz	—	<2.2:1 Input <2.5:1 Output
Impedance	50 Ω	50 Ω
Reverse isolation	>40 dB	>40 dB
Maximum DC input voltage	± 10 V	± 10 V
Typical risetime	400 ps	420 ps
Typical group delay	1.1 ns ^a	1.5 ns ^b
Net weight	3 lbs 8 oz (1.59 kg)	3 lbs 8 oz (1.59 kg)
Option 001	3 lbs 14 oz (1.75 kg)	—
Option 010	3 lbs 1 oz (1.84 kg)	3 lbs 10 oz (1.64 kg)
Option 011	4 lbs 10 oz (1.64 kg)	—
Dimensions	8 1/2 in (216 mm) by 5-1/2 in (130 mm) by 3-3/8 in (85.8 mm)	
Power Requirements	115 or 230 Vac $\pm 10\%$, 48 to 440 Hz, 15 Watts, 27 V _{Amax}	
Environmental	Operation: 0°C to +55°C Storage: -40°C to +75°C	

a. Variation over any 50 MHz band from 0.1-1300 MHz is typically <0.15 ns.

b. Variation over any 50 MHz band from 0.1-1300 MHz is typically <0.25 ns.

Table 2 HP 8447F Specifications

Specifications	HP 8447F		HP 8447F H64	
	Preamp	Power Amp	Preamp	Low Freq. Preamp
Frequency range	0.1 to 1300 MHz	0.1 to 1300 MHz	0.1 to 1300 MHz	9 kHz to 50 MHz
Typical 3 dB bandwidth (Std, Opt 001 and Opt 011)	.075 to 1700 MHz	.075 to 1400 MHz	.075 to 1700 MHz	6 kHz to 400 MHz
Mean Gain (20° to 30°C)	25 dB minimum	22 dB ± 2.0dB	25 dB minimum	26 dB minimum
Gain flatness across frequency range	± 1.5 dB	± 1.5 dB	± 1.5 dB	± 2 dB
Noise Figure	<8.5 dB	<11 dB (typical)	<8.5 dB	—
Output power for 1 dB gain compression	>+7 dBm (typical)	≥+12.5 dBm (0.1 to 1000 MHz)	>+7 dBm (typical)	>+15 dBm (0.1 to 1000 MHz)
Harmonic distortion	−30 dB for 0 dBm output (typical)	−30 dB for +8 dBm output	−30 dB for 0 dBm output (typical)	−35 dBc for +10 dBm output
Typical output for <−60 dB harmonic distortion	−30 dBm	−20 dBm	−30 dBm	−2 dBm
VSWR, 9 kHz to 50 MHz	—	—	—	<2.0:1
VSWR, 1 to 1300 MHz	<2.0:1 Input <2.2:1 Output	—	<2.0:1 Input <2.2:1 Output	
VSWR, 1 to 1400 MHz	—	<2.2:1 Input <2.5:1 Output	—	
Impedance	50 Ω	50 Ω	50 Ω	50 Ω
Reverse isolation	>40 dB	>40 dB	>40 dB	—
Maximum DC input voltage	±10 V	±10 V	±10 V	±10 V
Typical risetime	400 ps	420 ps	400 ps	—
Typical group delay	1.1 ns ^a	1.5 ns ^b	1.1 ns ^a	—
Net weight	3 lbs 14 oz (1.75 kg)		3 lbs 14 oz (1.75 kg)	
Option 001	—		—	

Table 2 HP 8447F Specifications

Specifications	HP 8447F		HP 8447F H64	
	Preamp	Power Amp	Preamp	Low Freq. Preamp
Option 010	4 lbs 1 oz (1.84 kg)		4 lbs 1 oz (1.84 kg)	
Dimensions	8 1/2 in (216 mm) by 5-1/2 in (130 mm) by 3-3/8 in (85.8 mm)			
Power Requirements	115 or 230 Vac \pm 10%, 48 to 440 Hz, 15 Watts, 27 VAm _{ax}			
Environmental	Operation: 0°C to +55°C Storage: -40°C to +75°C			

- a. Variation over any 50 MHz band from 0.1-1300 MHz is typically <0.15 ns.
- b. Variation over any 50 MHz band from 0.1-1300 MHz is typically <0.25 ns.

Table 3 HP 8447F H64 Characteristics

Characteristics	HP 8447F H64	
	Preamp	Low Freq. Preamp
Noise figure 9 kHz to 20 kHz 20 kHz to 100 kHz 100 kHz to 50 MHz	—	<12.0 dB <9.0 dB <7.0 dB
Typical mean gain (20° to 30°C)	—	28 dB

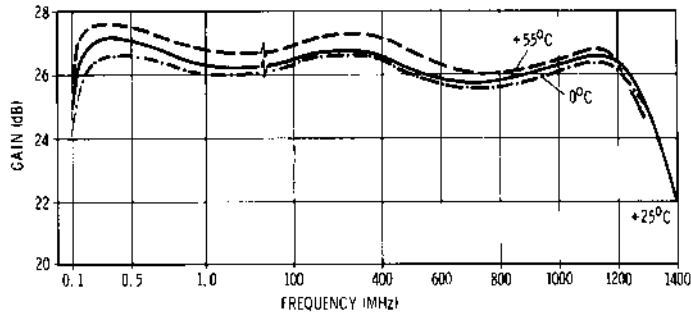

Gain vs. Frequency vs. Temperature

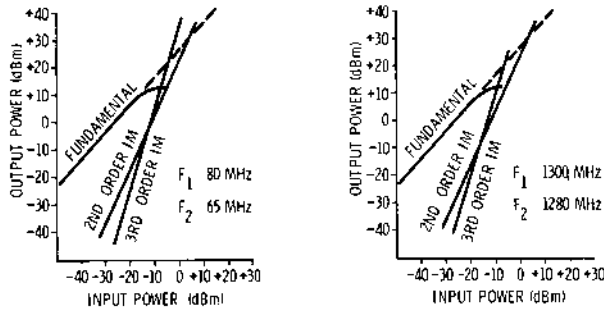

Intermodulation Intercept Points

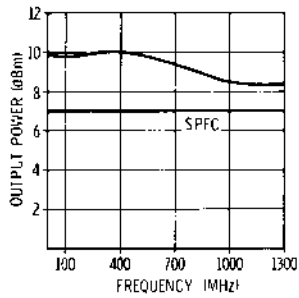

Output Power (1 dB Compression) vs. Frequency

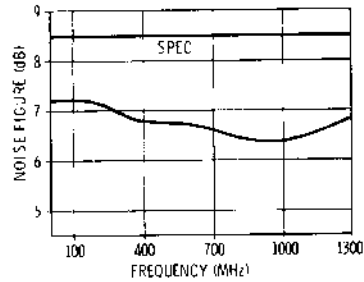

Noise Figure vs. Frequency

Figure 1

Typical Preamplifier Performance Curves

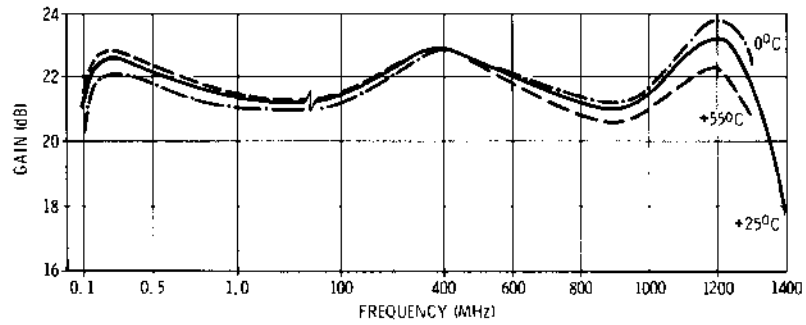

Gain vs. Frequency vs. Temperature

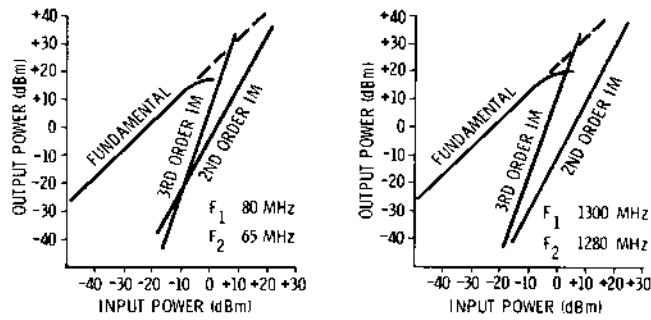

Intermodulation Intercept Points

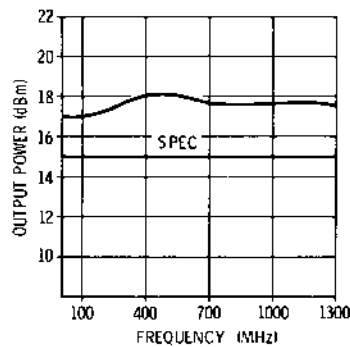

Output Power (1 dB Compression) vs. Frequency

Figure 2

Typical Power Amplifier Performance Curves

Options

The HP 8447D is a single preamplifier with BNC connectors. However, to provide flexibility, three options are offered:

- a Option 001 dual preamplifier, BNC connectors.
- b Option 010 single preamplifier, Type-N connectors.
- c Option 011 dual preamplifier, Type-N connectors.

The HP 8447E is a power amplifier with BNC connectors. One option is offered:

Option 010, Type-N connectors.

The HP 8447F is a preamplifier and a power amplifier with BNC connectors. One option is offered:

Option 010, Type-N connectors.

Option H64, Two preamplifiers with Type-N connectors. This option is not offered in conjunction with any other options.

NOTE:

Dual amplifier option 010 is furnished with a rigid coaxial cable (W6), with Type-N connectors, that can be used to cascade the amplifiers with minimum loss. The option H64 dual amplifier is not supplied with this cable.

Instruments Covered by this Manual

This manual fully documents the HP 8447D, HP 8447E and the HP 8447F. Any references in the manual apply to all three amplifiers unless otherwise noted.

Each amplifier has a ten digit serial number on the serial plate on the rear panel. The first five digits of the serial number are a prefix. The contents of this manual apply directly to instruments with the same serial number prefix as listed on the inside title page.

Revisions required to adapt the manual to other serial number prefixes are contained in a yellow "Manual Changes" insert supplied with the manual. For information about serial number prefixes not listed on the title page or in the insert, contact your nearest Hewlett-Packard office.

DECLARATION OF CONFORMITY

according to ISO/IEC Guide 22 and EN 45014

Manufacturer's Name: *Hewlett-Packard Co.*

Manufacturer's Address: *Microwave Instruments Division
1400 Fountaingrove Parkway
Santa Rosa, CA 95403-1799
USA*

declares that the product

Product Name: *Amplifier*

Model Number: *HP 8447A, HP 8447D, HP 8447E,
HP 8447F*

Product Options: *This declaration covers all options of the
above products.*

conforms to the following Product specifications:

*Safety: IEC 348:1978/HD 401 S1:1981
CAN/CSA-C22.2 No. 231 (Series M-89)*

*EMC: CISPR 11:1990/EN 55011:1991 Group 1, Class A
IEC 801-2:1984/EN 50082-1:1992 4 kV CD, 8 kV AD
IEC 801-3:1984/EN 50082-1:1992 3 V/m, 27-500 MHz
IEC 801-4:1988/EN 50082-1:1992 0.5 kV Sig. Lines, 1 kV Power Lines*

*IEC 555-2:1982 +A1:1985 / EN 60555-2:1987
IEC 555-3:1982 + A1:1990 / EN 60555-3:1987 + A1:1991*

Supplementary Information:

*The product herewith complies with the requirements of the Low Voltage Directive
73/23/EEC and the EMC Directive 89/336/EEC.*

Safety qualification tests for these products was performed prior to 1 December 1993.

Santa Rosa, California, USA 29 Dec. 1995

Dixon Browder/Quality Manager

*European Contact: Your local Hewlett-Packard Sales and Service Office or Hewlett-Packard GmbH, Department HQ-TRE,
Herrenberger Strasse 130, D-71034 Böblingen, Germany (FAX +49-7031-14-3143)*

Receiving and Operating

Initial Inspection

Mechanical Check

If damage to the shipping carton is evident, ask the carrier's agent to be present when the instrument is unpacked. Inspect the instrument for mechanical damage. Also check the cushioning material for signs of severe stress.

Performance Check

The electrical performance of an amplifier should be verified upon receipt. Performance checks suitable for incoming inspections are given in the performance test section.

Claims for Damage

If the instrument is mechanically damaged in transit, notify the carrier and the nearest Hewlett-Packard field office immediately. A list of field offices is contained in the back of this manual. Retain the shipping carton and padding material for the carrier's inspection. The field office will arrange for replacement or repair of your instrument without delay for claim settlements against the carrier. Before shipment, this instrument was inspected and found free of mechanical and electrical defects. If there is any deficiency, or if electrical performance is not within specifications, notify your nearest Hewlett-Packard sales and service office.

Preparation For Use

Power Requirements

The amplifier operates from 115 or 230 volt ac line voltages, at any line frequency between 48 and 440 Hz. A slide switch on the rear panel is set to the correct position for the line voltage available.

Power Cable

To protect operating personnel, the National Electrical Manufacturer's Association (NEMA) recommends that the instrument panel and cabinet be grounded. All Hewlett-Packard instruments are equipped with a three-conductor power cable which, when plugged into the appropriate receptacle, grounds the instrument. The

offset pin on the power cable's three-prong connector is the ground wire. The power cord and power input connector meet the specifications established by the International Electrotechnical Commission (IEC).

CAUTION: Always use the three-prong ac power cord supplied with this instrument. Failure to ensure adequate earth grounding by not using this cord may cause instrument damage.

Mating Connectors

Mating connectors used with the amplifier should be 50 Ω type BNC male. If the amplifier has the optional Type-N connectors, use Type-N male connectors that are compatible with US MIL-C-39012.

Operating Environment

The operating range of the amplifier is from 0°C to +55°C. The amplifier can be stored in a temperature range of -40°C to +75°C.

Bench Use

The amplifier is equipped with plastic feet and tilt stand in place, ready for use as a bench instrument.

WARNING: **If this product is not used as specified, the protection provided by the equipment could be impaired. This product must be used in a normal condition only (in which all means for protection are intact).**

Rack Mounting

The amplifier may be rack mounted by using an adapter frame. The adapter frame is a rack frame that accepts several combinations of sub-modular units. For additional information, address inquiries to your nearest Hewlett-Packard sales and service office.

Storage and Shipment

Packaging

The following paragraphs contain a general guide to repackaging of the instrument for shipment. Refer to them for information about using the original packaging, or using other packaging.

If the instrument is to be shipped to Hewlett-Packard for service or repairs, attach a tag to the instrument identifying the owner and indicating the service or repair required. Include the model number and full serial number of the instrument.

Original Packaging

If the original container is to be used, proceed as follows:

- a Place instrument in original container. If it is not available, a suitable container can be purchased from your nearest Hewlett-Packard sales and service office.
- b Be sure the container is well sealed with strong tape or a metal band.

Other Packing Material

If the original container is not used, proceed as follows:

- a Wrap the instrument in heavy paper or anti-static plastic before placing in inner anti-static container.
- b Place packing material around all sides of the instrument and protect panel face with cardboard strips.
- c Place instrument in a heavy carton and seal with strong tape. A double-wall carton made of 200 pound test material is adequate.
- d Mark shipping container; "Delicate Instrument. Fragile."

Operating Instructions

Connect the line power cable to the three-prong rear panel socket and proceed as follows:

- a Select the line power to be used (115V or 230V) with the rear panel SELECTOR switch.
- b Connect the line power cable to line power and press the LINE switch.

CAUTION:

The input to the HP 8447D/E/F and the HP 8447F Option H64 amplifiers is very susceptible to damage from electrostatic discharge. Before connecting any coaxial cable to the input jack of the amplifier, make certain that static electricity buildup in the cable is completely discharged.

Do not apply power levels to the amplifier that are higher than the following:

- HP 8447D: 0 dBm
 - HP 8447E: -10 dBm
 - HP 8447F preamp: 0 dBm
 - HP 8447F power amp: +10 dBm
-

- c Attach INPUT and OUTPUT cables.

CAUTION

Power out of the HP 8447E and power out of the HP 8447F power amp can exceed 100 mW. This may be enough power to damage sensitive circuits connected to the OUTPUT.

Operator Maintenance

Operator maintenance is limited to replacement of the front panel LINE switch light, the A1 power supply fuse, and the rear panel fuse. Clean the cabinet using a damp cloth only.

Fuses

To replace the rear panel fuse (F1), remove the rear panel fuse knob and replace the fuse (see rear panel for value of F1).

To replace the A1 power supply (A1F1) fuse, turn the instrument on its top. Lift the tilt stand and remove the bottom cover. Replace the fuse on the A1 Power Supply board (see parts list for the value of A1F1).

WARNING:

For continued protection against fire hazard replace line fuse only with same type and rating ([0.5A/250V]). The use of other fuses or material is prohibited.

Lamp Replacement

To replace the front panel line switch lamp (DS1), proceed as follows:

- a Disconnect cord from rear panel receptacle.
- b Pull the white cover portion of this switch from the instrument and then remove the lamp from inside the cover.
- c Replace old lamp with a new lamp (see parts list for part number of DS1).
- d Place white cover into switch receptacle.
- e Align tab on white cover with socket and push in.

WARNING:

No operator serviceable parts inside. Refer servicing to qualified personnel. To prevent electrical shock, do not remove covers.

Performance Tests Procedures

Test equipment and accessories required to perform maintenance are listed in Table 4. Equipment other than recommended models can be used provided the minimum specifications are satisfied.

The performance tests assume the use of a standard amplifier with BNC connectors. If an amplifier with Type-N connectors is to be tested, suitable adapters will have to be added to the equipment lists.

The performance tests and adjustment procedure cover all three amplifiers. Where required, test steps list equipment settings, and other additional information, for each amplifier. If a test step lists only one setting or specification, it is valid for all three amplifiers. Disregard references to any amplifier not being tested.

Table 4 Recommended Test Equipment and Accessories

Instrument Type	Minimum Specifications	Suggested Model	Use^a
Generator/Sweeper	Frequency Range: 0.1 to 110 MHz Flatness: ± 0.25 dB over full range Output Level: +10 dBm minimum Frequency Accuracy: 1% ± 100 kHz Compatible with network analyzer	HP 8601A	P,T
Generator/Sweeper	Frequency Range: 9 kHz to 50MHz Flatness: ± 0.25 dB over full range Output Level: +10 dBm minimum Frequency Accuracy: 1% ± 100 kHz Compatible with network analyzer	HP 3335A	P,T (for testing opt H64)
Sweep Oscillator	Frequency Range: 0.1 to 1.3 GHz Flatness: 0.7 dB over full range Output Level: +10 dBm minimum Frequency Accuracy: ± 20 MHz Compatible with network analyzer	HP 8620A/8621A	P,T

Table 4 Recommended Test Equipment and Accessories

Instrument Type	Minimum Specifications	Suggested Model	Use ^a
Network analyzer (0.1-110 MHz)	System with a swept source capable of measuring the amplitude of reflected signals return loss. Frequency range: 0.1 to 1300 MHz Resolution: 0.25 dB Accuracy: $\pm 6\%$	HP 8407A	P
Network analyzer (0.11 -1.4 GHz)		HP 8410A	
Phase-magnitude display		HP 8412A	
Harmonic frequency converter		HP 8411A	
S-parameter test set		HP 8745A	
Universal extension		HP 11604A	
Transmission kit		HP 11651A	
Accessory kit		HP 11570A	
Spectrum analyzer RF section	Frequency range: 10-1300 MHz Dynamic range: 60 dB minimum Scan width: 800 MHz minimum Spurious responses: < -60 dB Absolute amplitude calibration. Variable persistence display.	HP 8555A	P
Spectrum analyzer IF section		HP 8552A	
Display section		HP 141T	
Noise figure meter	Frequency range: 0.1-1300 MHz Noise figure range: 0-15 dB Accuracy: ± 0.5 dB Excess noise ratio: 6.3 ± 0.5 dB	HP 342A	P
VHF noise source		HP 343A	
UHF noise source		HP 349A	
RMS voltmeter	Voltage range: 1mV to 1V (full range) Frequency range: 10 Hz to 10 MHz Meter accuracy: $\pm 5\%$	HP 3400A	P,A,T
Power meter	Power range: -20 dBm to $+10$ dBm Frequency range: 10-1300 MHz Meter accuracy: $\pm 1\%$	HP 432A/478A	P
Amplifier	Gain: 24 dB Noise: < 8 dB Frequency range: 0.1-130 MHz	HP 8447D	P

Table 4 Recommended Test Equipment and Accessories

Instrument Type	Minimum Specifications	Suggested Model	Use^a
Digital voltmeter	Voltage range: 0-60V Accuracy: $\pm 0.05\%$ ± 1 digit	HP 3440A/3444A	A, T
Double balanced mixers	Frequency range: 200-1300 MHz	Sage Laboratories 2500 Series	P
Low pass filter	Cutoff frequency: 400 MHz Attenuation: >60 dB at 800 and 1200 MHz	Cir-Q-Tel FLT/2 Series	P
Attenuator	10 dB, 0.1-1300 MHz	HP 8491A Option 010	P
Attenuator	20 dB, 0.1-1300 MHz	HP 8491A Option 020	P
Termination	50 Ω (BNC)	HP 11593A	P
Termination	50 Ω (Type-N)	HP 908A	P
Adapter	Type-N female to BNC male	UG-349A/U	P
Adapter	BNC female to Type-N male	UG-209A/U	P
Tee	BNC	UG-274B/U	P
Cable assembly	Type-N connectors	HP 11500A	P
Cable assembly (5)	BNC connectors	HP 10503A	P
Cable assembly	BNC with test clips attached	HP 10501A	A,T
Adapter	BNC female to binding post	HP 10111A	P, A, T
Adapter	BNC male to BNC male	UG-491A/U	P

a.P=Performance Test, A=Adjustments, T=Troubleshooting

Gain Flatness, Mean Gain, and Gain Compression Test

Specifications:

	HP 8447D Preamp	HP 8447E Power amp	HP 8447F		HP 8447F H64	
			Preamp	Power Amp	Preamp	Low Freq Preamp
Gain flatness across full frequency range	±1.5 dB	±1.5 dB	±1.5 dB	±1.5 dB	±1.5 dB	±2 dB
Mean Gain (20°C-30°C)	25 dB min.	22 dB ±2.0 dB	25 dB min.	22 dB ±2.0 dB	25 dB min.	26 dB min.
Output power for 1 dB gain compression	—	>+12.5 dBm	—	>+12.5 dBm	—	>+15 dBm

Description:

Amplifier gain is measured at the maximum and minimum points of its frequency response. See Figure 1 and Figure 2. The difference between highest measured gain and lowest measured gain should be less than 3 dB (gain flatness). Half of the sum of the highest gain and lowest gain is the measured mean gain and should be within 2.0 dB of the specified gain. Compression is checked by measuring gain at the specified 1 dB compression point and comparing it to gain measured below compression.

Equipment:

- Generator/sweeper HP 8601A
- Sweep oscillator HP 8620A/8621A
- RMS voltmeter HP 3400A
- Power meter HP 432A/478A
- BNC cable assembly (2) HP 10503A
- BNC tee UP-247B/U
- 50 Ω termination HP 11593A
- Adapter UG-349A/U
- Adapter UG-201A/U
- Adapter HP 1250-0080
- 20 dB attenuator HP 8491B-20
- 10 dB attenuator HP 8491B-10

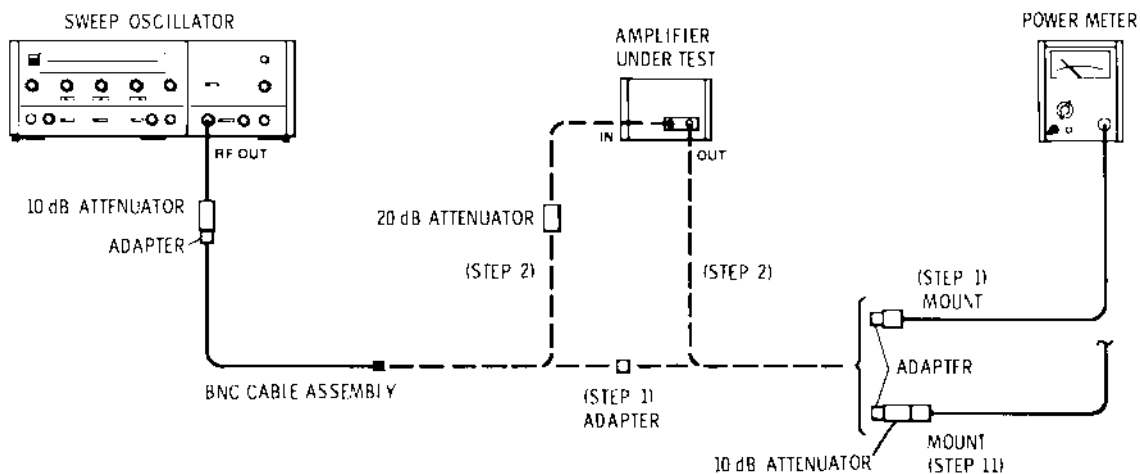

Figure 3 Gain Test Setup: 10 MHz to 1.3 GHz

Procedure:

- 1 To measure gain flatness and mean gain, connect the equipment as shown in Figure 3. Set the sweep oscillator for a 1.3 GHz, leveled, CW signal. Set the signal level for -10 dBm out of the 10 dB attenuator (read on the power meter).
- 2 Disconnect the power meter from the sweep oscillator and 10 dB attenuator. Connect the sweep oscillator, through the 10 dB and 20 dB attenuators, to the amplifier INPUT. Connect the power meter to the amplifier OUTPUT. Note the power meter reading. Use this reading to calculate amplifier gain.

Example:

-7 dBm (read in step 2) minus -10 dBm (set in step 1) plus 20 dB (read from attenuator) = 23 dB (gain)

Gain at 1300 MHz: _____ dB

NOTE:

Use the attenuation printed on the 20 dB attenuator. This may vary slightly, depending upon the frequency.

- 3 Tune the sweep oscillator for a maximum indication on the power meter at 1150 ± 100 MHz. Disconnect the oscillator and the power meter from the amplifier. Connect the power meter, through the 10 dB attenuator, to the oscillator. Set the oscillator signal level for -10 dBm out of the attenuator.
- 4 Disconnect the power meter from the sweep oscillator and 10 dB attenuator. Connect the oscillator, through the 10 dB and 20 dB attenuators, to the amplifier INPUT. Con-

nect the power meter to the amplifier OUTPUT. Calculate and record the amplifier gain as in step 2.

Gain at 1150 MHz: _____ dB

- 5 Measure, calculate and record the amplifier gain at the following frequencies. Use the procedures outlined in steps 3 and 4.

Frequency	Gain
800 ±200 MHz (tune for minimum):	_____ dB
350 ±100 MHz (tune for minimum):	_____ dB

- 6 Disconnect the sweep oscillator and the power meter from the amplifier. Connect the equipment as shown in Figure 4. Set the generator/sweeper for a 10 MHz, CW signal. Set the signal level for -40 dB (read on the voltmeter).
- 7 Disconnect the voltmeter from the generator/sweeper. Connect the generator/sweeper to the amplifier INPUT. Connect the voltmeter, with the 50 Ω termination, to the amplifier OUTPUT. Note the voltmeter reading. Use this reading to calculate the amplifier gain.

Example:

-18.5 dB (read in step 7) minus -40 dB (set in step 6) = 21.5 dB (gain)

Gain at 1300 MHz: _____ dB

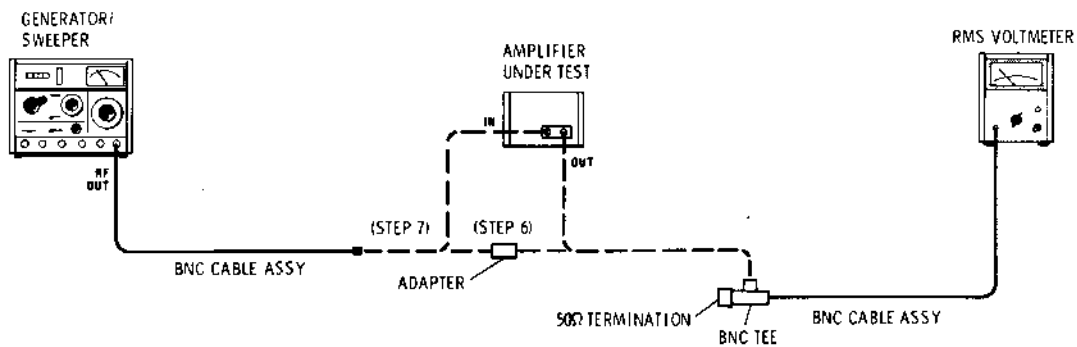

Figure 4

Flatness and Mean Gain Test Setup: 100 kHz to 10 MHz

- 8 Measure, calculate and record amplifier gain at the following frequencies. Use the procedures outlined above.

Operation and Service Manual
Performance Tests Procedures

Frequency	Gain
250 ±100 kHz (tune for maximum):	_____dB
100 kHz:	_____dB

For HP 8447F H64 low frequency preamp, replace the generator/sweeper shown in Figure 4 with HP 3335A synthesizer (or equivalent). Set the synthesizer for a 9 kHz, CW signal. Repeat step 7. Measure, calculate and record the amplifier gain at 9 kHz.

HP 8447F H64 Frequency	Gain
9 kHz:	_____dB

- 9 Select the highest and lowest gains from steps 2, 4, 5, 7, and 8. Subtract the lowest gain from the highest gain. The result is gain flatness and should be less than 3 dB.

Example:

23 dB (highest gain) minus 21.5 dB (lowest gain) = 1.5 dB (gain flatness)

Gain flatness: _____dB

For HP 8447F H64 low frequency preamp, select the highest and lowest gains from steps 7, and 8. Subtract the lowest gain from the highest gain. The result is gain flatness and should be less than 4 dB (± 2 dB). Add the highest and lowest gains together and divide by 2. The result is measured gain.

Measured gain: _____dB

- 10 Add the highest and lowest gains together and divide by 2. The result is the measured mean gain.

Example:

$\frac{23 \text{ dB (highest gain)} + 21.5 \text{ dB (lowest gain)}}{2} = 22.25 \text{ dB (mean gain)}$

Mean Gain	Min	Actual	Max
HP 8447D	25 dB	_____	
HP 8447E	20 dB	_____	24 dB
HP 8447F preamp	25 dB	_____	
HP 8447F power amp	20 dB	_____	24 dB

NOTE: Gain rolls off rapidly above 1300 MHz and below 0.1 MHz. If the lowest gain was measured at either of these points, use a frequency counter to monitor the signal and repeat steps 1 through 10.

- 11** To check compression, connect the power meter mount, through the 10 dB attenuator, to the amplifier OUTPUT as shown in Figure 3. Connect the sweep oscillator, through the 20 dB attenuator, to the amplifier INPUT. Set the sweep oscillator for a leveled, 650 MHz, CW signal and set the signal level (read on the power meter) as follows:

(For the HP 8447F H64 low frequency preamp set the 3335A to 10 MHz)

HP 8447E: +2.5 dBm (+11.5 dBm ampl. output)

HP 8447F power amp: +2.5 dBm (+11.5 dBm ampl. output)

- 12** Without changing any of the sweep oscillator settings, move the 10 dB attenuator from the amplifier OUTPUT to the amplifier INPUT. The power meter should now be connected directly to the amplifier OUTPUT and the sweep oscillator should be connected through the 20 dB attenuator and the 10 dB attenuator to the amplifier INPUT.

- 13** The power meter should read as follows:

HP 8447E less than +3.5 dBm: _____ dBm

HP 8447F power amp less than +3.5 dBm: _____ dBm

HP 8447F H64 low frequency preamp less than +6 dBm: _____ dBm

- 14** Repeat steps 11 through 13 at various frequencies between 0.1 and 1300 MHz.

For the HP 8447F H64 low frequency preamp repeat steps 11 through 13 at various frequencies between 0.1 to 50 MHz.

VSWR Test Procedure

Specifications, VSWR:

HP 8447D Preamp (1 to 1300 MHz)	HP 8447E Power Amp (0.75 to 1400 MHz)	HP 8447F		HP 8447F H64	
		Preamp (1 to 1300 MHz)	Power Amp (0.75 to 1400 MHz)	Preamp (1 to 1300 MHz)	Low Freq Preamp (1 to 50 MHz)
<2.0 Input	<2.2 Input	<2.0 Input	<2.2 Input	<2.0 Input	<2.0 Input
<2.2 Output	<2.5 Output	<2.2 Output	<2.5 Output	<2.2 Output	<2.2 Output

Description:

A network analyzer is swept, in steps, from 1 to 1300 MHz (or 1400 MHz). At each step the analyzer display is referenced to 1 dB return loss by shorting its output. The short is then removed and the amplifier return loss is measured at the INPUT and OUTPUT.

Equipment:

Sweep oscillator	HP 8620A/8621A
Generator/sweeper	HP 8601A
Network analyzer (0.1 to 110 MHz)	HP 8407A
Network analyzer (0.11 to 1.4 GHz)	HP 8410A
Phase-magnitude display	HP 8412A
Harmonic frequency converter	HP 8411A
S-parameter test set	HP 8745A
Universal extension	HP 11604A
Transmission kit	HP 11651A
Accessory kit	HP 11570A
Cable assembly (3)	HP 10503A
Cable assembly	HP 11500A

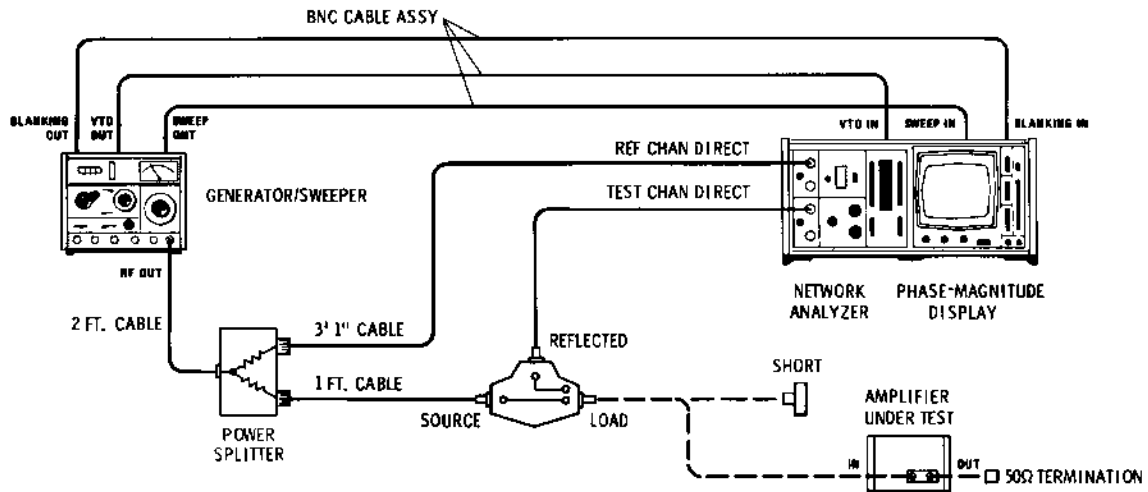

Figure 5 VSWR Test Setup: 1 to 110 MHz

Procedure:

- 1 Connect the equipment as shown in Figure 5. Set the generator/sweeper for a -10 dBm signal, sweeping from 1 to 110 MHz.
- 2 Connect the short to the directional bridge and calibrate the network analyzer for a 0 dB return loss reference on the display (use the center horizontal graticule line).
- 3 Remove the short from the directional coupler, attach the coupler to the amplifier INPUT. (Terminate the OUTPUT with 50Ω .)
- 4 Decrease the display reference level to -10 dB. The center horizontal graticule line now represents a return loss of 10 dB. The measured return loss should be as shown below:

INPUT VSWR, 1 to 110 MHz

HP 8447D, >9.6 dB: _____ HP 8447F Preamp, >9.6 dB: _____
 HP 8447E, >8.8 dB: _____ HP 8447F Power amp, >8.8 dB: _____
 HP 8447F Option H64 Low frequency preamp, 1 to 50 MHz >9.6 dB: _____

- 5 Measure return loss at the amplifier OUTPUT. Terminate the INPUT with 50Ω . The measured return loss should be as shown below.

For the HP 8447F option H64 low frequency preamp, steps 7 through 11 are not needed.

HP 8447D Output VSWR, 1 to 110 MHz:	>8.8 dB	_____
HP 8447E/F Output VSWR, 1 to 110 MHz:	>7.7 dB	_____
HP 8447F Option H64 low frequency preamp Output VSWR, 1 to 50 MHz:	>9.6 dB	_____

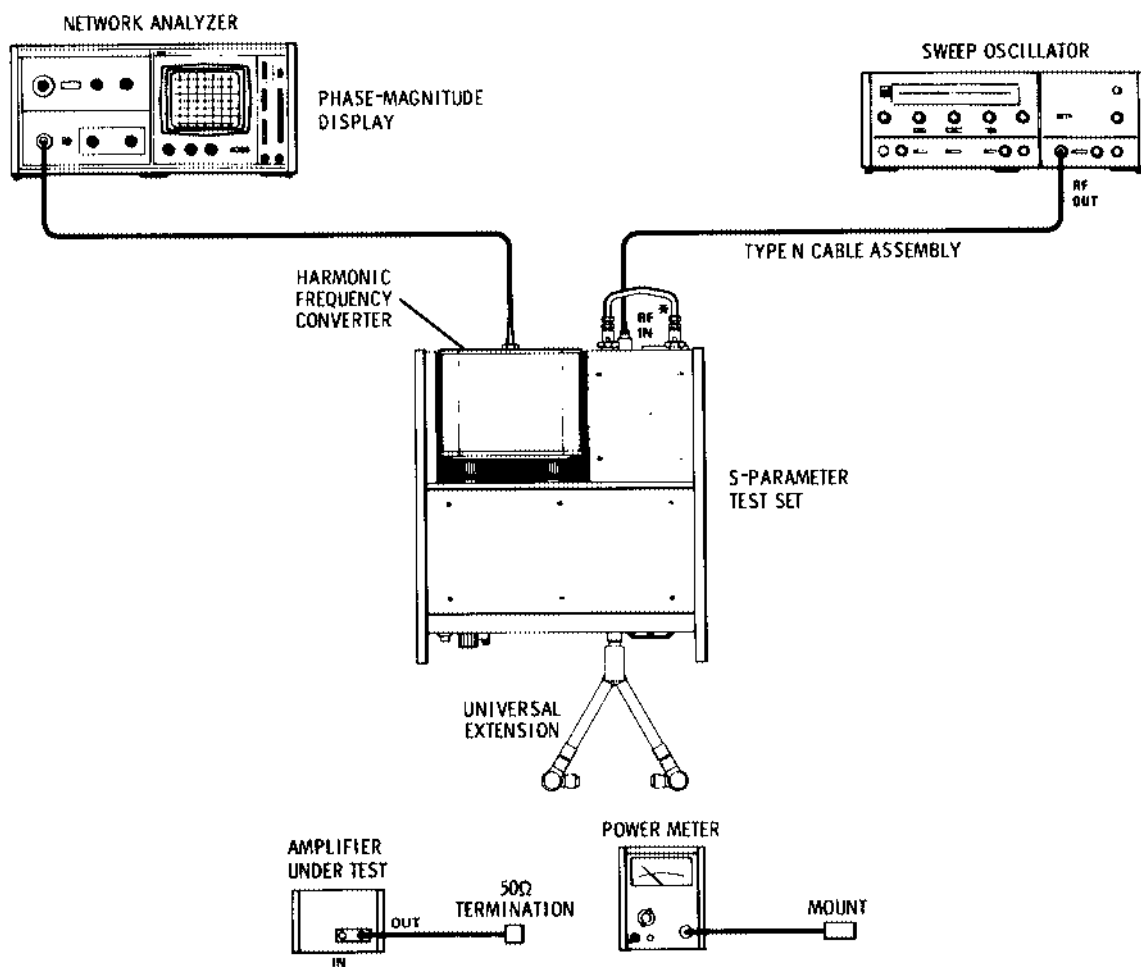

Figure 6

VSWR Test Setup: 0.11 to 1.3 GHz

- 6 Connect the equipment as shown in Figure 6. Set the sweep oscillator for a leveled CW signal, sweeping from 110 to 220 MHz. Connect the power meter to the s-parameter test set INPUT PORT A and set the generator/sweeper output level for -15 dBm as read on the power meter.

- 7 Disconnect the power meter from the test set and connect a short to INPUT PORT A (measuring S_{11} at INPUT PORT A). Calibrate the network analyzer for a 0 dB return loss reference on the display. Use the center horizontal graticule line. Note the TEST CHANNEL GAIN at the reference:

Reference TEST CHAN. GAIN, 110 to 220 MHz: _____dB

- 8 Disconnect the short from INPUT PORT A. Terminate the amplifier OUTPUT with 50 Ω . Connect INPUT PORT A to the amplifier INPUT.
- 9 Set the TEST CHANNEL GAIN 10 dB above the reference in step 7. The center horizontal graticule line now represents a return loss of 10 dB. The measured return loss should be as shown below:

INPUT VSWR, 110 to 220 MHz

HP 8447D, >9.6 dB: _____ HP 8447F Preamp, >9.6 dB: _____

HP 8447E, >8.8 dB: _____ HP 8447F Power amp, >8.8 dB: _____

- 10 Repeat steps 8 and 9, measuring return loss at the amplifier OUTPUT. Terminate the amplifier INPUT with 50 Ω . The measured return loss should be as shown below:

HP 8447D Output VSWR, 110 to 220 MHz: 8.8 dB _____

HP 8447E/F Output VSWR, 110 to 220 MHz: 7.7 dB _____

- 11 Set the sweep oscillator to sweep each of the ranges shown below, repeating steps 7 through 10 for each range.

Sweep Range	Reference, Test Chan. Gain	HP 8447D Input, HP 8447F Preamp Input	HP 8447D Output, HP 8447E Input, HP 8447F Power Amp Input	HP 8447E/F Output
220 to 440 MHz	_____dB	_____dB	_____dB	_____dB
440 to 880 MHz	_____dB	_____dB	_____dB	_____dB
880 to 1300 MHz	_____dB	_____dB	_____dB	_____dB

Distortion and Reverse Isolation Test Procedure

Specifications:

Specification	HP 8447D Preamp	HP 8447E Power Amp	HP 8447F		HP 8447F H64	
			Preamp	Power Amp	Preamp	Low Freq Preamp
Harmonic Distortion	—	−30 dB for +8 dBm output	—	−30 dB for +8 dBm output	—	−35 dB for +10 dBm output
Reverse Isolation	>40 dB	>40 dB	>40 dB	>40 dB	>40 dB	—

Description:

A fixed, CW signal at 400 MHz is filtered and applied to the amplifier INPUT. The amplifier OUTPUT is connected to a spectrum analyzer, and the analyzer is used to check the second and third harmonic levels. Reverse isolation is checked by applying a known signal level to the amplifier OUTPUT and measuring it at the amplifier INPUT.

Equipment:

- Spectrum analyzer HP 141T/8552A/8555A
- Sweep oscillator HP 8620A/8621A
- 400 MHz low pass filter Cir-Q-Tel FLT/2 Series
- Cable assembly HP 10503A
- Adapter UG-201A/U
- 10 dB attenuator HP 8491B-10
- Adapter UG-349A/U
- Cable assembly HP 11500A

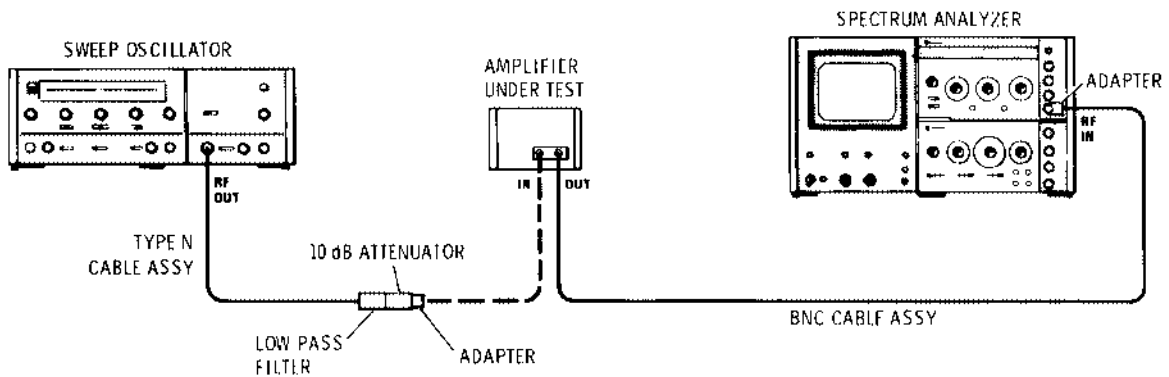

Figure 7 **Distortion and Reverse Isolation Test Setup**

Procedure:

- 1 To check distortion, connect the equipment as shown in Figure 7. Set the sweep oscillator for a fixed, 400 MHz CW signal.
For the HP 8447F option H64 low frequency preamp, set the frequency to 10 MHz.
- 2 Set the spectrum analyzer input attenuator as shown below. Adjust the controls to display 400 through 1200 MHz.
For the HP 8447F option H64 low frequency preamp, set the controls to display 10 through 30 MHz.

NOTE:

The signal into the spectrum analyzer input mixer must be low enough to eliminate harmonic distortion in the spectrum analyzer.

- 3 Set the sweep oscillator output level for the following signal levels out of the amplifier (read on the spectrum analyzer).

	Signal Level	Spectrum Analyzer Input Attenuation
HP 8447E:	+8 dBm	50 dB
HP 8447F Power Amp:	+8 dBm	50 dB
HP 8447F H64 Low freq preamp:	+10 dBm	50 dB

- 4 Note the level of the second harmonic at 800 MHz and the third harmonic at 1200 MHz.

The harmonic signal levels should be >30 dB below the fundamental.

For the HP 8447F option H64 low frequency preamp, note the level of the second harmonic at 20 MHz and the third harmonic at 30 MHz. The harmonic signal levels should be >35 dB below the fundamental.

Harmonic Distortion, 30 dB down: _____
 HP 8447F H64 Harmonic Distortion, 35 dB down: _____

- 5 To check reverse isolation, disconnect the oscillator and the spectrum analyzer from the amplifier, reduce the oscillator's output level, then connect the oscillator to the spectrum analyzer.
- 6 Set the oscillator output level for a 0 dBm signal as read on the spectrum analyzer. Connect the spectrum analyzer to the amplifier INPUT. Connect the oscillator to the amplifier OUTPUT.
- 7 Read the level of feed-through directly on the spectrum analyzer. It should be below -40 dBm:

Reverse isolation, >40 dB down: _____

Noise Figure Test Procedure

Specifications:

Noise Figure: <8.5 dB (for the HP 8447D and HP 8447F preamp)

Characteristics

Noise Figure: <7.0 dB (for the HP 8447F option H64 low frequency preamp)

Description:

Noise figure is checked at 100 MHz by inserting a known amount of excess noise into the amplifier under test. The known noise is then compared to the amplifier's noise level with a noise figure meter. Noise is checked at 200 MHz using a 1300MHz signal source and a mixer to convert the noise to 100 MHz. Then it is measured with the meter.

Equipment:

- Noise figure meter HP 342A
- VHF noise source HP 343A
- UHF noise source HP 349A
- Sweep oscillator HP 8620A/8621A
- Double balanced mixers SL 2513/2523

50Ω termination	HP 908A
Amplifier	HP 8447D
Power meter	HP 432A/478A
Adapter	UG-491/U
Cable assembly (5).....	HP 10503A
Adapter (2).....	UG-201A/U

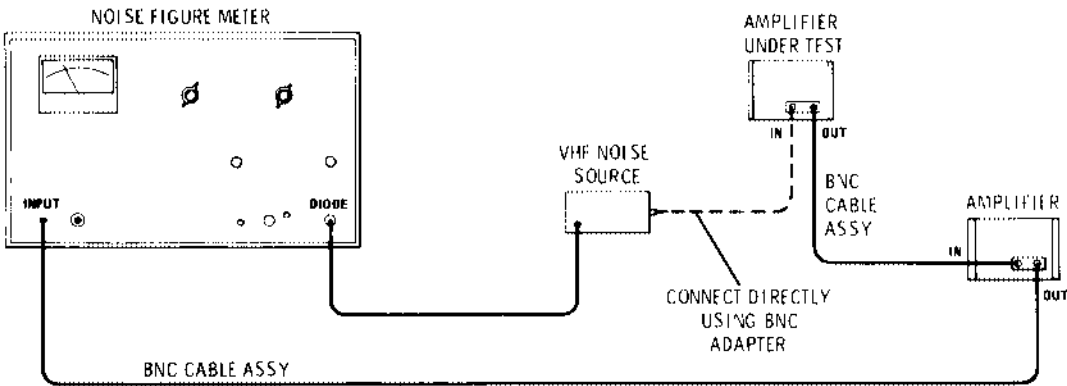

Figure 8 Noise Figure Test Setup: 100 MHz

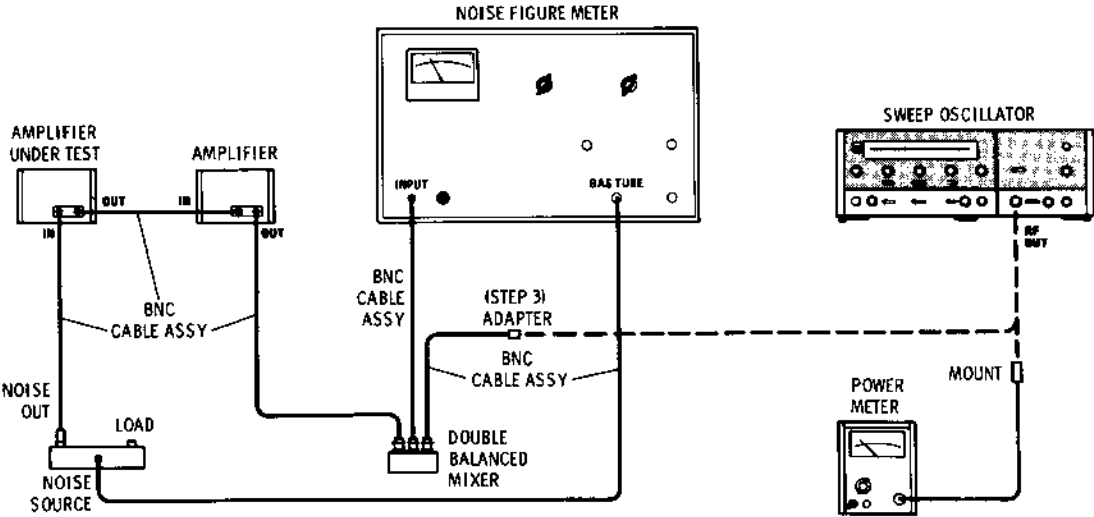

Figure 9 Noise Figure Test Setup: 1200 MHz

Procedure:

- 1 Connect the equipment as shown in Figure 8. Calibrate the noise figure meter. Check the amplifier's noise figure at 100 MHz (or 105 MHz). It should be less than 8.5 dB.

For the HP 8447F option H64 low frequency preamp, check the amplifier's noise figure at 30 MHz. It should be less than 7 dB.

	100 MHz:	_____
HP 8447F H64 low frequency preamp	30 MHz:	_____

- 2 Connect the equipment as shown in Figure 9. Set the sweep oscillator for a fixed, CW signal at 1300 MHz. Set the signal level out of the oscillator for +10 dBm, read on the power meter.
- 3 Disconnect the power meter from the oscillator and connect the oscillator to the mixer.
- 4 Set the noise figure meter to measure noise at 100 MHz. Calibrate the meter.

NOTE:

If the noise figure meter being used has a 105 MHz input frequency, set the sweep oscillator (in step 2) to 1305 MHz.

- 5 Check the amplifier's noise figure. It should be less than 8.5 dB.

1200 MHz: _____

Adjustment Procedure

Power Supply Voltage Check and Adjustment

Description:

To insure that the amplifier gives proper gain, the power supply is adjusted to 20V \pm 0.1V.

Equipment:

Digital voltmeter	HP 3440A/3444A
RMS voltmeter	HP 3400A
Cable assembly (w/test clips)	HP 10501A
Adapter	HP 10111A

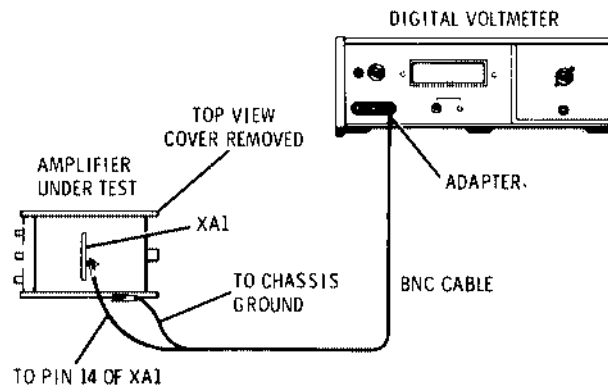

Figure 10

Power Supply Voltage Adjustment Test Setup

Procedure:

- 1 Connect the test setup in Figure 10. Set the digital voltmeter to measure +20V dc.
- 2 Adjust A1R9 VOLT ADJ for a digital voltmeter reading of +20V \pm 0.1V dc.

DVM: +19.9V dc _____ +20.1V dc

- 3 Remove the digital voltmeter from the amplifier and connect the RMS voltmeter to XA1 pin 14. The ripple voltage should be as shown below.

Parts and Service

Replaceable Parts

The following tables list parts in alpha-numerical order of their reference designations. It is important that you refer to the table that documents the instrument being serviced. Cabinet parts for all three amplifiers are listed in Figure 11. HP 8447D/E/F Cabinet Parts. Figure 12. HP 8447D/E/F Type-N Connector (Options 010 and 011) lists the parts that make up the Type-N connector used in amplifier Options 010 and 100.

Ordering Information

To obtain replacement parts, address order or inquiry to your local Hewlett-Packard field office. See the list at the end of the manual for addresses. Identify parts by their Hewlett-Packard part numbers.

To obtain a part that is not listed, include:

- a Instrument model number
- b Instrument serial number
- c Description of the part
- d Function and location of the part

Table 5

Reference Designators

A	= assembly	K	= relay	TB	= terminal board
B	= motor	L	= inductor	TP	= test point
BT	= battery	LS	= loud speaker	U	= integrated circuit
C	= capacitor	M	= meter	V	= vacuum tube, neon bulb, photocell, etc.
CP	= coupler	MK	= microphone	VR	= voltage regulator
CR	= diode	MP	= mechanical part	W	= cable
DL	= delay line	P	= plug	X	= socket
DS	= lamp, device signal	Q	= transistor	Y	= crystal
E	= misc. electronic part	R	= resistor	Z	= tuned cavity, network
F	= fuse	RT	= thermistor		
FL	= filter	S	= switch		
J	= jack	T	= transformer		

Table 6 Abbreviations

A	= amperes	CCW	= counterclockwise	DEPC	= deposited carbon
AFC	= automatic frequency control	CER	= ceramic	DR	= drive
AMPL	= amplifier	CMO	= cabinet mount only	ELECT	= electrolytic
BFO	= beat freq oscillator	COEF	= coefficient	ENCAP	= encapsulated
BECU	= beryllium copper	COM	= common	EXT	= external
BH	= binder head	COMP	= composition	F	= farads
BP	= bandpass	COMPL	= complete	FH	= flat head
BRS	= brass	CONN	= connector	FILH	= Fillister head
BWO	= backward wave oscillator	CP	= cadmium plate	FXD	= fixed
		CRT	= cathode-ray-tube		
		CW	= clockwise		
G	= giga (10^9)	IMPG	= impregnated	M	= milli (10^{-3})
GE	= germanium	INCD	= incandescent	MEG	= meg (10^6)
GL	= glass	INCL	= include(s)	METFLM	= metal film
GRD	= ground(ed)	INS	= insulation(ed)	METOX	= metallic oxide
H	= henries	INT	= internal	MFR	= manufacturer
HDW	= hardware	K	= kilo (1000)	MHz	= mega Hertz
DEX	= hexagonal	LH	= left hand	MINAT	= miniature
HG	= mercury	LIN	= linear taper	MOM	= momentary
HR	= hour(s)	LKWASH	= lock washer	MOS	= metalized substrate
Hz	= Hertz	LOG	= logarithmic taper	MTG	= mounting
IF	= intermediate freq	LPF	= low pass filter	MY	= mylar
N	= nano (10^{-9})	OBD	= order by description	PORC	= porcelain
N/C	= normally closed	OH	= oval head	POS	= position(s)
NE	= neon	OX	= oxide	POTZ	= potentiometer
NIPL	= nickel plate	P	= peak	PP	= peak-to-peak
N/O	= normally open	PC	= printed circuit	PT	= point
NOM	= nominal	PF	= picofarads (10^{-12} F)	PWV	= peak working voltage
NPO	= negative positive zero (zero temp coefficient)	PHBRZ	= phosphor bronze	RECT	= rectifier
NPN	= negative-positive-neg	PHL	= Phillips	RF	= radio frequency
NRFR	= not recommended for field replacement	PIV	= peak inverse voltage	RH	= round head, right hand
NSR	= not separately replaceable	PNP	= positive-negative-pos	RMO	= rack mount only
		P/O	= part of	RMS	= root-mean square
		POLY	= polystyrene	RWV	= reverse working volt

Operation and Service Manual
Parts and Service

Table 6 **Abbreviations**

S-B	= slow-blow	TA	= tantalum	W/	= with
SCR	= screw	TD	= time delay	W	= watts
SE	= selenium	TGL	= toggle	WIV	= working inverse voltage
SECT	= section(s)	THD	= thread	WW	= wirewound
SEMICN	= semiconductor	TI	= titanium	W/O	= without
SI	= silicon	TOL	= tolerance		
SIL	= silver	TRIM	= trimmer		
SL	= slide	TWT	= traveling wave tube		
SPG	= spring				
SPL	= special	μ	= micro (10 ⁻⁶)		
SST	= stainless steel				
SR	= split ring	VAR	= variable		
STL	= steel	VDCW	= dc working volts		

Table 7 **Code List of Manufacturers**

Mfr No	Manufacturer Name	Address	Zip Code
01121	Allen Bradley Co.	Milwaukee, WI	53204
01921	RCA Solid State Div.	Somerville, NJ	08876
02037	Motorola Semiconductor Products	Phoenix, AZ	85008
04009	Arrow, Hart & Hegeman Electric Co.	Hartford, CT	06106
04703	Littelfuse Inc.	Des Plaines, IL	60016
04757	Oak Ind. Inc., Sw Div.	Crystal Lake, IL	60014
07263	Fairchild Camera & Instr. Corp., Semiconductor Div.	Mountain View, CA	94040
12954	Dickson Electronic Corp.	Scottsdale, AZ	85282
28480	Hewlett-Packard Co.	Palo Alto, CA	94304
56289	Sprague Electric Co.	N. Adams, MA	01247
70903	Belden Corp.	Chicago, IL	60644
71590	Globe Union Inc. Central Lab Div.	Milwaukee, WI	53201
71785	Cinch Mfg. Co., Div TRW Inc.	Elk Grove Village, IL	
78189	Shakeproof Div. Illinois Tool Works	Elgin, IL	60120
80131	Electronic Industries Association	Washington, DC	20006
82389	Switchcraft Inc.	Chicago, IL	60630
87034	Marcoak Industries	Anaheim, CA	92803
91506	Augat, Inc.	Attleboro, MA	02703

Parts Lists

Table 8 HP 8447D Replaceable Parts

Ref Des	HP Part Number	CD	qty	Description	Mfr Code	Mfr Part Number
A1	08447-60045	0	1	Board Assy: Power Supply	28480	08447-60045
A1C1	0150-0024	7	1	C: fixd cer 0.02 uF +80-20% 600 Vdcw	71590	Type DD 203
A1C2	0180-0228	6	1	C: fixd elect 22 uF 10% 15 Vdcw	56289	150D226X9015B2DYS
A1C3	0160-0162	5	1	C: fixd my 0.022 uF 10% 200 Vdcw	56289	192P22392-PTS
A1C4	0180-0116	1	1	C: fixd elect 6.8uF 10% 35 Vdcw	56289	150D685X9035B2DYS
A1C5	0180-1819	3	1	C: fixd elect 100 uF +75-10% 50 Vdcw	56289	150D226X9015B2DYS
A1CR1	1901-0743	1	4	Diode: pwr rect IN4004 400VIA DO-41	28480	1901-0743
A1CR2	1901-0743	1		Diode: pwr rect IN4004 400VIA DO-41	28480	1901-0743
A1CR3	1901-0743	1		Diode: pwr rect IN4004 400VIA DO-41	28480	1901-0743
A1CR4	1901-0743	1		Diode: pwr rect IN4004 400VIA DO-41	28480	1901-0743
A1CR5	1920-3002	1	1	Diode: breakdown 3.16V 5%	28480	1920-3002
A1CR6	1902-0761	5	1	Diode: breakdown 5.9 - 6.5V	12954	1N821
A1CR7	1901-0025	2	2	Diode: silicon 100 mA/1V	07263	FD 2387
A1CR8	1902-3268	3	1	Diode: breakdown 26.1V 5%	28480	1902-3268
A1CR9	1884-0073	2	1	Thyristor-scr TO-5 VRRM=100	01921	SCR1400
A1CR10	1901-0025	2		Diode: silicon 100 mA/1V	07263	FD 2387
A1F1	2110-0012	0	2	Fuse: 0.5 amp 250V	04703	312.500
A1F1	2110-0269	9	1	Clip: fuse: 0.250" diam.	91506	6008-32CN
A1Q1	1853-0012	4	1	Xstr: si PNP	80131	2N2904A
A1Q2	1854-0022	8	1	Xstr: si NPN	07263	S17843
A1Q3	1854-0071	7	3	Xstr: si NPN (selected from 2N3704)	28480	1854-0071
A1Q4	1854-0071	7		Xstr: si NPN (selected from 2N3704)	28480	1854-0071
A1Q5	1854-0071	7		Xstr: si NPN (selected from 2N3704)	28480	1854-0071
A1R1	0757-0836	6	1	R: fixd met flm 7.50 kohm 1% 1/2W	28480	0757-0836
A1R2	0698-7238	9	1	R: fixd met flm 1.78 kohm 1% 1/8W	28480	0698-7238
A1R3	0757-0836	5	1	R: fixd met flm 7.50 kohm 1% 1/2W	28480	0757-0836
A1R4	0811-1732	8	1	R: fixd WW 1.5 ohm 5% Type V 1W	28480	0811-1732
A1R5	0698-0089	4	1	R: fixd met flm 1780 ohm 1% 1/8W	28480	0698-0089
A1R6	0698-0083	8	1	R: fixd met flm 1.96 kohm 1% 1/8W	28480	0698-0083
A1R7	0698-3440	7	1	R: fixd met flm 196 ohm 1% 1/8W	28480	0698-3440
A1R8	0757-0416	7	1	R: fixd met flm 511 ohm 1% 1/8W	28480	0757-0416
A1R9	2100-1758	3	1	R: var ww 1 kohm 5% Type V 1W	28480	2100-1758
A1R10	0698-3154	0	1	R: fixd met flm 4.22 kohm 1% 1/8W	28480	0698-0083
A1R11	0757-1094	9	1	R: fixd met flm 1.47 kohm 1% 1/8W	28480	0757-1094

Operation and Service Manual
Parts and Service

Table 8 HP 8447D Replaceable Parts

Ref Des	HP Part Number	CD	qty	Description	Mfr Code	Mfr Part Number
A1R12	0698-3442	9	1	R: fixd met flm 237 ohm 1% 1/8W	28480	0698-3442
A1R13	0757-0180	2	1	R: fixd met flm 31.6 ohm 1% 1/8W	28480	0757-0180
A1R14	0757-0401	0		R: fixd met flm 100 ohm 1% 1/8W	28480	0757-0401
C1	0180-2805	9	1	C: fixd elect 850 uF +50-10% 75VDCW	28480	0180-2805
C2	0160-2049	1	1	C: fixd cer feedthru 5000 pF +80-20%	28480	0160-2049
C3	0180-0291	3	1	C: fixd elect 1.0 uF 10% 35 VDCW	56289	150D105X9035A2DYS
DS1	2140-0244	4	1	Lamp: glow miniature 95V	87034	A1H
F1	2110-0012	1		Fuse: 0.5A 250V	04703	312.500
J1	1251-2357	8	1	Socket: 3-pin male power (part of rear panel)	82389	EAC-301
J2				Part of W2		
J3				Part of W3		
J4				Part of W4		
J5				Part of W5		
L1	9100-1618	1	2	Coil: molded choke 5.60 uH	28480	9100-1618
L2	9100-1618	1		Coil: molded choke 5.60 uH (Opt 001 and 011 only)	28480	9100-1618
MP1	08447-00005	6	1	Insulator: top cover	28480	08447-00005
MP2	08447-00028	3	1	Support: amplifier (Opt 001 and 011 only)	28480	08447-00028
Q1	1854-0063	7	1	Xstr: si NPN	80131	2N3055
R1	0683-2735	0	1	R: fixd comp 27 kohm 5% 1/4W	01121	CB 2735
S1	3101-2139	9	1	Switch-pb DPST-NO altng 10.5A 250Vac	28480	3101-2139
S1	3101-2195		1	for HP 8447D, serial no. 2727A06246 for HP 8447E, serial no. 2727A02669 for HP 8447F, serial no. 2805A03498	28480	3101-2195
S1	0590-0012	5	2	Nut: knurled 15/32-32	04009	899U-3
S2	3101-1234	3	1	Switch: slide DPDT	82389	11A-1242
T1	9100-2894	7	1	Transformer: power	28480	9100-2894
U1	5086-7767	7	1	Hybrid mc:pre-ampl 0.1-1300 MHz	28480	5086-7767
U2	5086-7767	7	1	Hybrid mc:pre-ampl 0.1-1300 MHz (Opt 001 and 011 only)	28480	5086-7767
W1	8120-1348	5	1	Cable assy: power, detachable	70903	KHS-7041
W2	08447-20002	5	1	Cable assy: Type-N INPUT (Opt 010 and 011 only)	28480	08447-20002

Table 8 HP 8447D Replaceable Parts

Ref Des	HP Part Number	CD	qty	Description	Mfr Code	Mfr Part Number
W2	08447-20006	9	1	Cable assy: BNC INPUT	28480	08447-20006
W3	08447-20003	6	1	Cable assy: Type-N OUTPUT (Opt 010 and 011 only)	28480	08447-20003
W3	08447-20007	0	1	Cable assy: BNC OUTPUT	28480	08447-20007
W4	08447-20004	7	1	Cable assy: Type-N INPUT (Opt 011)	28480	08447-20004
W4	08447-20008	1	1	Cable assy: BNC INPUT (Opt 001)	28480	08447-20008
W5	08447-20005	8	1	Cable assy: Type-N OUTPUT (Opt 011)	28480	08447-20005
W5	08447-20009	2	1	Cable assy: BNC OUTPUT (Opt 001)	28480	08447-20009
W6	08447-20014	9	1	Cable assy: jumper (Opt 011 only)	28480	08447-20014
XF1				Fuseholder (includes the following parts)		
XF1MP1	2110-0564	8	1	Fuseholder body 12A max for UL	28480	2110-0564
XF1MP2	2110-0565	9	1	Fuseholder cap 12A max for UL	28480	2110-0565
XF1MP3	2110-0569	3	1	Nut-fuseholder thread	28480	2110-0569
XQ1	0340-1114		1	Insulator: xstr mounting (TO-3)	28480	0340-1114
XF1MP4	1400-0090	9	1	Washer	28480	1400-0090
	0360-0368	7	1	Termination: solder stud	78189	2168-12-01
	0900-0016	8	1	O-ring 0.688" OD	00000	OBD

Table 9 HP 8447E Replaceable Parts

Ref Des	HP Part Number	CD	qty	Description	Mfr Code	Mfr Part Number
A1	08447-60045	0	1	Board Assy: Power Supply	28480	08447-60045
A1C1	0150-0024	7	1	C: fixd cer 0.02 uF +80-20% 600 Vdcw	71590	Type DD 203
A1C2	0180-0228	6	1	C: fixd elect 22 uF 10% 15 Vdcw	56289	150D226X9015B2DYS
A1C3	0160-0162	5	1	C: fixd my 0.022 uF 10% 200 Vdcw	56289	192P22392-PTS
A1C4	0180-0116	1	1	C: fixd elect 6.8uF 10% 35 Vdcw	56289	150D685X9035B2DYS
A1C5	0180-1819	3	1	C: fixd elect 100 uF +75-10% 50 Vdcw	56289	150D226X9015B2DYS
A1CR1	1901-0743	1	4	Diode: pwr rect IN4004 400VIA DO-41	28480	1901-0743
A1CR2	1901-0743	1		Diode: pwr rect IN4004 400VIA DO-41	28480	1901-0743
A1CR3	1901-0743	1		Diode: pwr rect IN4004 400VIA DO-41	28480	1901-0743
A1CR4	1901-0743	1		Diode: pwr rect IN4004 400VIA DO-41	28480	1901-0743
A1CR5	1920-3002	1	1	Diode: breakdown 3.16V 5%	28480	1920-3002
A1CR6	1902-0761	5	1	Diode: breakdown 5.9 - 6.5V	12954	1N821
A1CR7	1901-0025	2	2	Diode: silicon 100 mA/1V	07263	FD 2387
A1CR8	1902-3268	3	1	Diode: breakdown 26.1V 5%	28480	1902-3268
A1CR9	1884-0073	2	1	Thyristor-scr TO-5 VRRM=100	01921	SCR1400
A1CR10	1901-0025	2		Diode: silicon 100 mA/1V	07263	FD 2387
A1F1	2110-0012	0	2	Fuse: 0.5 amp 250V	04703	312.500
A1F1	2110-0726	9	1	Clip: fuse: 0.250" diam.	91506	6008-32CN
A1Q1	1853-0012	4	1	Xstr: si PNP	80131	2N2904A
A1Q2	1854-0022	8	1	Xstr: si NPN	07263	S17843
A1Q3	1854-0071	7	3	Xstr: si NPN (selected from 2N3704)	28480	1854-0071
A1Q4	1854-0071	7		Xstr: si NPN (selected from 2N3704)	28480	1854-0071
A1Q5	1854-0071	7		Xstr: si NPN (selected from 2N3704)	28480	1854-0071
A1R1	0757-0836	6	1	R: fixd met flm 7.50 kohm 1% 1/2W	28480	0757-0836
A1R2	0698-7238	9	1	R: fixd met flm 1.78 kohm 1% 1/8W	28480	0698-7238
A1R3	0757-0836	5	1	R: fixd met flm 7.50 kohm 1% 1/2W	28480	0757-0836
A1R4	0811-1832	8	1	R: fixd WW 1.5 ohm 5% Type V 1W	28480	0811-1832
A1R5	0698-0089	4	1	R: fixd met flm 1780 ohm 1% 1/8W	28480	0698-0089
A1R6	0698-0083	8	1	R: fixd met flm 1.96 kohm 1% 1/8W	28480	0698-0083
A1R7	0698-3440	7	1	R: fixd met flm 196 ohm 1% 1/8W	28480	0698-3440
A1R8	0757-0416	7	1	R: fixd met flm 511 ohm 1% 1/8W	28480	0757-0416
A1R9	2100-1758	3	1	R: var ww 1 kohm 5% Type V 1W	28480	2100-1758
A1R10	0698-3154	0	1	R: fixd met flm 4.22 kohm 1% 1/8W	28480	0698-0083
A1R11	0757-1094	9	1	R: fixd met flm 1.47 kohm 1% 1/8W	28480	0757-1094

Table 9 HP 8447E Replaceable Parts

Ref Des	HP Part Number	CD	qty	Description	Mfr Code	Mfr Part Number
A1R12	0698-3442	9	1	R: fixd met flm 237 ohm 1% 1/8W	28480	0698-3442
A1R13	0757-0180	2	1	R: fixd met flm 31.6 ohm 1% 1/8W	28480	0757-0180
A1R14	0757-0401	0		R: fixd met flm 100 ohm 1% 1/8W	28480	0757-0401
C1	0180-2805	9	1	C: fixd elect 850 uF +50-10% 75VDCW	28480	0180-2805
C2	0160-2049	1	1	C: fixd cer feedthru 5000 pF +80-20%	28480	0160-2049
C3	0180-0291	3	1	C: fixd elect 1.0 uF 10% 35 VDCW	56289	150D105X9035A2DYS
DS1	2140-0244	4	1	Lamp: glow miniature 95V	87034	A1H
F1	2110-0012	1		Fuse: 0.5A 250V	04703	312.500
J1	1251-2357	8	1	Socket: 3-pin male power (part of rear panel)	82389	EAC-301
J2				Part of W2		
J3				Part of W3		
L1	9100-1618	1	2	Coil: molded choke 5.60 uH	28480	9100-1618
L2	9100-1618	1		Coil: molded choke 5.60 uH (Opt 001 and 011 only)	28480	9100-1618
MP1	08447-00005	6	1	Insulator: top cover	28480	08447-00005
Q1	1854-0063	7	1	Xstr: si NPN	80131	2N3055
R1	0683-2735	0	1	R: fixd comp 27 kohm 5% 1/4W	01121	CB 2735
S1	3101-2139	9	1	Switch-pb DPST-NO altng 10.5A 250Vac	28480	3101-2139
S1	3101-2195		1	for HP 8447D, serial no. 2727A06246 for HP 8447E, serial no. 2727A02669 for HP 8447F, serial no. 2805A03498	28480	3101-2195
S1	0590-0012	5	2	Nut: knurled 15/32-32	04009	899U-3
S2	3101-1234	3	1	Switch: slide DPDT	82389	11A-1242
T1	9100-2894	7	1	Transformer: power	28480	9100-2894
U1	5086-7768	7	1	Hybrid mc:power-ampl 0.1-1300 MHz	28480	5086-7767
U1	08447-60029			5086-7768 replacement kit (for use with 08447-60045 assy).	28480	08447-60029
W1	8120-1348	5	1	Cable assy: power, detachable	70903	KHS-7041
W2	08447-20002	5	1	Cable assy: Type-N INPUT (Opt 010 and 011 only)	28480	08447-20002
W2	08447-20006	9	1	Cable assy: BNC INPUT	28480	08447-20006
W3	08447-20003	6	1	Cable assy: Type-N OUTPUT (Opt 010 and 011 only)	28480	08447-20003
W3	08447-20007	0	1	Cable assy: BNC OUTPUT	28480	08447-20007

Operation and Service Manual
Parts and Service

Table 9 HP 8447E Replaceable Parts

Ref Des	HP Part Number	CD	qty	Description	Mfr Code	Mfr Part Number
XF1				Fuseholder (includes the following parts)		
XF1MP1	2110-0564	8	1	Fuseholder body 12A max for UL	28480	2110-0564
XF1MP2	2110-0565	9	1	Fuseholder cap 12A max for UL	28480	2110-0565
XF1MP3	2110-0569	3	1	Nut-fuseholder thread	28480	2110-0569
XQ1	0340-0664		1	Insulator: xstr mounting (TO-3)	28480	0340-0664
XF1MP4	1400-0090	9	1	Washer: lock sst for 1/2 thread	28480	1400-0090
	0360-0368	7	1	Termination: solder stud	78189	2168-12-01
	0900-0016	8	1	O-ring 0.688" OD	00000	OBD

Table 10 HP 8447F Replaceable Parts

Ref Des	HP Part Number	CD	qty	Description	Mfr Code	Mfr Part Number
A1	08447-60045	0	1	Board Assy: Power Supply	28480	08447-60045
A1C1	0150-0024	7	1	C: fixd cer 0.02 uF +80-20% 600 Vdcw	71590	Type DD 203
A1C2	0180-0228	6	1	C: fixd elect 22 uF 10% 15 Vdcw	56289	150D226X9015B2DYS
A1C3	0160-0162	5	1	C: fixd my 0.022 uF 10% 200 Vdcw	56289	192P22392-PTS
A1C4	0180-0116	1	1	C: fixd elect 6.8uF 10% 35 Vdcw	56289	150D685X9035B2DYS
A1C5	0180-1819	3	1	C: fixd elect 100 uF +75-10% 50 Vdcw	56289	150D226X9015B2DYS
A1CR1	1901-0743	1	4	Diode: pwr rect IN4004 400VIA DO-41	28480	1901-0743
A1CR2	1901-0743	1		Diode: pwr rect IN4004 400VIA DO-41	28480	1901-0743
A1CR3	1901-0743	1		Diode: pwr rect IN4004 400VIA DO-41	28480	1901-0743
A1CR4	1901-0743	1		Diode: pwr rect IN4004 400VIA DO-41	28480	1901-0743
A1CR5	1920-3002	1	1	Diode: breakdown 3.16V 5%	28480	1920-3002
A1CR6	1902-0761	5	1	Diode: breakdown 5.9 - 6.5V	12954	1N821
A1CR7	1901-0025	2	2	Diode: silicon 100 mA/1V	07263	FD 2387
A1CR8	1902-3268	3	1	Diode: breakdown 26.1V 5%	28480	1902-3268
A1CR9	1884-0073	2	1	Thyristor-scr TO-5 VRRM=100	01921	SCR1400
A1CR10	1901-0025	2		Diode: silicon 100 mA/1V	07263	FD 2387
A1F1	2110-0012	0	2	Fuse: 0.5 amp 250V	04703	312.500
A1F1	2110-0269	9	1	Clip: fuse: 0.250" diam.	91506	6008-32CN
A1Q1	1853-0012	4	1	Xstr: si PNP	80131	2N2904A
A1Q2	1854-0022	8	1	Xstr: si NPN	07263	S17843
A1Q3	1854-0071	7	3	Xstr: si NPN (selected from 2N3704)	28480	1854-0071
A1Q4	1854-0071	7		Xstr: si NPN (selected from 2N3704)	28480	1854-0071
A1Q5	1854-0071	7		Xstr: si NPN (selected from 2N3704)	28480	1854-0071
A1R1	0757-0836	6	1	R: fixd met flm 7.50 kohm 1% 1/2W	28480	0757-0836
A1R2	0698-7238	9	1	R: fixd met flm 1.78 kohm 1% 1/8W	28480	0698-7238
A1R3	0757-0836	5	1	R: fixd met flm 7.50 kohm 1% 1/2W	28480	0757-0836
A1R4	0811-1732	8	1	R: fixd WW 1.5 ohm 5% Type V 1W	28480	0811-1732
A1R5	0698-0089	4	1	R: fixd met flm 1780 ohm 1% 1/8W	28480	0698-0089
A1R6	0698-0083	8	1	R: fixd met flm 1.96 kohm 1% 1/8W	28480	0698-0083
A1R7	0698-3440	7	1	R: fixd met flm 196 ohm 1% 1/8W	28480	0698-3440
A1R8	0757-0416	7	1	R: fixd met flm 511 ohm 1% 1/8W	28480	0757-0416
A1R9	2100-1758	3	1	R: var ww 1 kohm 5% Type V 1W	28480	2100-1758
A1R10	0698-3154	0	1	R: fixd met flm 4.22 kohm 1% 1/8W	28480	0698-0083
A1R11	0757-1094	9	1	R: fixd met flm 1.47 kohm 1% 1/8W	28480	0757-1094

Operation and Service Manual
Parts and Service

Table 10 HP 8447F Replaceable Parts

Ref Des	HP Part Number	CD	qty	Description	Mfr Code	Mfr Part Number
A1R12	0698-3442	9	1	R: fixd met flm 237 ohm 1% 1/8W	28480	0698-3442
A1R13	0757-0180	2	1	R: fixd met flm 31.6 ohm 1% 1/8W	28480	0757-0180
A1R14	0757-0401	0		R: fixd met flm 100 ohm 1% 1/8W	28480	0757-0401
C1	0180-2805	9	1	C: fixd elect 850 uF +50-10% 75VDCW	28480	0180-2805
C2	0160-2049	1	1	C: fixd cer feedthru 5000 pF +80-20%	28480	0160-2049
C3	0180-0291	3	1	C: fixd elect 1.0 uF 10% 35 VDCW	56289	150D105X9035A2DYS
DS1	2140-0244	4	1	Lamp: glow miniature 95V	87034	A1H
F1	2110-0012	1		Fuse: 0.5A 250V	04703	312.500
J1	1251-2357	8	1	Socket: 3-pin male power (part of rear panel)	82389	EAC-301
J2				Part of W2		
J3				Part of W3		
J4				Part of W4		
J5				Part of W5		
L1	9100-1618	1	2	Coil: molded choke 5.60 uH	28480	9100-1618
L2	9100-1618	1		Coil: molded choke 5.60 uH (Opt 001 and 011 only)	28480	9100-1618
MP1	08447-00005	6	1	Insulator: top cover	28480	08447-00005
MP2	08447-00028	3	1	Support: amplifier (Opt 001 and 011 only)	28480	08447-00028
Q1	1854-0063	7	1	Xstr: si NPN	80131	2N3055
R1	0683-2735	0	1	R: fixd comp 27 kohm 5% 1/4W	01121	CB 2735
S1	3101-2139	9	1	Switch-pb DPST-NO altng 10.5A 250Vac	28480	3101-2139
S1	3101-2195		1	for HP 8447D, serial no. 2727A06246 for HP 8447E, serial no. 2727A02669 for HP 8447F, serial no. 2805A03498	28480	3101-2195
S1	0590-0012	5	2	Nut: knurled 15/32-32	04009	899U-3
S2	3101-1234	3	1	Switch: slide DPDT	82389	11A-1242
T1	9100-2894	7	1	Transformer: power	28480	9100-2894
U1	5086-7768	7	1	Hybrid mc:power-ampl 0.1-1300 MHz	28480	5086-7768
U1	08447-60029			5086-7768 replacement kit (for use with 08447-60045 assy).	28480	08447-60029
U2	5086-7767	7	1	Hybrid mc:pre-ampl 0.1-1300 MHz (Opt 001 and 011 only)	28480	5086-7767

Table 10 HP 8447F Replaceable Parts

Ref Des	HP Part Number	CD	qty	Description	Mfr Code	Mfr Part Number
U2	08447-60044			5086-7767 replacement kit (for use with 08447-60045 assy).	28480	08447-60044
W1	8120-1348	5	1	Cable assy: power, detachable	70903	KHS-7041
W2	08447-20002	5	1	Cable assy: Type-N INPUT (Opt 010 and 011 only)	28480	08447-20002
W2	08447-20006	9	1	Cable assy: BNC INPUT	28480	08447-20006
W3	08447-20003	6	1	Cable assy: Type-N OUTPUT (Opt 010 and 011 only)	28480	08447-20003
W3	08447-20007	0	1	Cable assy: BNC OUTPUT	28480	08447-20007
W4	08447-20004	7	1	Cable assy: Type-N INPUT (Opt 010)	28480	08447-20004
W4	08447-20008	1	1	Cable assy: BNC INPUT	28480	08447-20008
W5	08447-20005	8	1	Cable assy: Type-N OUTPUT (Opt 010)	28480	08447-20005
W5	08447-20009	2	1	Cable assy: BNC OUTPUT	28480	08447-20009
W6	08447-20014	9	1	Cable assy: jumper (Opt 011 only)	28480	08447-20014
XF1				Fuseholder (includes the following parts)		
XF1MP1	2110-0564	8	1	Fuseholder body 12A max for UL	28480	2110-0564
XF1MP2	2110-0565	9	1	Fuseholder cap 12A max for UL	28480	2110-0565
XF1MP3	2110-0569	3	1	Nut-fuseholder thread	28480	2110-0569
XQ1	0340-0664		1	Insulator: xstr mounting (TO-3)	28480	0340-0664
XF1MP4	1400-0090	9	1	Washer: lock sst for 1/2 thread	28480	1400-0090
	0360-0368	7	1	Termination: solder stud	78189	2168-12-01
	0900-0016	8	1	O-ring 0.688" OD	00000	OBD

Table 11 HP 8447F H64 Replaceable Parts

Ref Des	HP Part Number	CD	qty	Description	Mfr Code	Mfr Part Number
A1	08447-60045	0	1	Board Assy: Power Supply	28480	08447-60045
A1C1	0150-0024	7	1	C: fixd cer 0.02 uF +80-20% 600 Vdcw	71590	Type DD 203
A1C2	0180-0228	6	1	C: fixd elect 22 uF 10% 15 Vdcw	56289	150D226X9015B2DYS
A1C3	0160-0162	5	1	C: fixd my 0.022 uF 10% 200 Vdcw	56289	192P22392-PTS
A1C4	0180-0116	1	1	C: fixd elect 6.8uF 10% 35 Vdcw	56289	150D685X9035B2DYS
A1C5	0180-1819	3	1	C: fixd elect 100 uF +75-10% 50 Vdcw	56289	150D226X9015B2DYS
A1CR1	1901-0743	1	4	Diode: pwr rect IN4004 400VIA DO-41	28480	1901-0743
A1CR2	1901-0743	1		Diode: pwr rect IN4004 400VIA DO-41	28480	1901-0743
A1CR3	1901-0743	1		Diode: pwr rect IN4004 400VIA DO-41	28480	1901-0743
A1CR4	1901-0743	1		Diode: pwr rect IN4004 400VIA DO-41	28480	1901-0743
A1CR5	1920-3002	1	1	Diode: breakdown 3.16V 5%	28480	1920-3002
A1CR6	1902-0761	5	1	Diode: breakdown 5.9 - 6.5V	12954	1N821
A1CR7	1901-0025	2	2	Diode: silicon 100 mA/1V	07263	FD 2387
A1CR8	1902-3268	3	1	Diode: breakdown 26.1V 5%	28480	1902-3268
A1CR9	1884-0073	2	1	Thyristor-scr TO-5 VRRM=100	01921	SCR1400
A1CR10	1901-0025	2		Diode: silicon 100 mA/1V	07263	FD 2387
A1F1	2110-0012	0	2	Fuse: 0.5 amp 250V	04703	312.500
A1F1	2110-0269	9	1	Clip: fuse: 0.250" diam.	91506	6008-32CN
A1Q1	1853-0012	4	1	Xstr: si PNP	80131	2N2904A
A1Q2	1854-0022	8	1	Xstr: si NPN	07263	S17843
A1Q3	1854-0071	7	3	Xstr: si NPN (selected from 2N3704)	28480	1854-0071
A1Q4	1854-0071	7		Xstr: si NPN (selected from 2N3704)	28480	1854-0071
A1Q5	1854-0071	7		Xstr: si NPN (selected from 2N3704)	28480	1854-0071
A1R1	0757-0836	6	1	R: fixd met flm 7.50 kohm 1% 1/2W	28480	0757-0836
A1R2	0698-7238	9	1	R: fixd met flm 1.78 kohm 1% 1/8W	28480	0698-7238
A1R3	0757-0836	5	1	R: fixd met flm 7.50 kohm 1% 1/2W	28480	0757-0836
A1R4	0811-1732	8	1	R: fixd WW 1.5 ohm 5% Type V 1W	28480	0811-1732
A1R5	0698-0089	4	1	R: fixd met flm 1780 ohm 1% 1/8W	28480	0698-0089
A1R6	0698-0083	8	1	R: fixd met flm 1.96 kohm 1% 1/8W	28480	0698-0083
A1R7	0698-3440	7	1	R: fixd met flm 196 ohm 1% 1/8W	28480	0698-3440
A1R8	0757-0416	7	1	R: fixd met flm 511 ohm 1% 1/8W	28480	0757-0416
A1R9	2100-1758	3	1	R: var ww 1 kohm 5% Type V 1W	28480	2100-1758
A1R10	0698-3154	0	1	R: fixd met flm 4.22 kohm 1% 1/8W	28480	0698-0083
A1R11	0757-1094	9	1	R: fixd met flm 1.47 kohm 1% 1/8W	28480	0757-1094

Table 11 HP 8447F H64 Replaceable Parts

Ref Des	HP Part Number	CD	qty	Description	Mfr Code	Mfr Part Number
A1R12	0698-3442	9	1	R: fixd met flm 237 ohm 1% 1/8W	28480	0698-3442
A1R13	0757-0180	2	1	R: fixd met flm 31.6 ohm 1% 1/8W	28480	0757-0180
A1R14	0757-0401	0		R: fixd met flm 100 ohm 1% 1/8W	28480	0757-0401
A2	08447-60038		1	Board Assy: H64 Amplifier	28480	08447-60038
A2C1	0160-4441		4	C: fixd cer 0.47 uF 50 Vdcw		
A2C2	0160-4441			C: fixd cer 0.47 uF 50 Vdcw		
A2C3	0160-4441			C: fixd cer 0.47 uF 50 Vdcw		
A2C4	0160-4441			C: fixd cer 0.47 uF 50 Vdcw		
A2J3	1250-1220		2	Conn: RF M SMC (output)		
A2J4	1250-1220			Conn: RF M SMC (input)		
A2L1	9140-0351		1	Coil: 18 nH 5%		
A2L2	9100-2486		1	Coil: 330 nH 5%		
A2MP1	1205-1220		2	Heatsink: T05/T39		
A2MP2	1205-1220			Heatsink: T05/T39		
A2MP3	3050-0082		2	Washer: fiber 0.116 ID 4		
A2MP4	3050-0082			Washer: fiber 0.116 ID 4		
A2Q1	1813-0213		2	IC: MWA130M1 amp		
A2Q2	1813-0213			IC: MWA130M1 amp)		
A2R1	0698-3631		1	R: fixd 330 ohm 5% 2W		
A2R2	0698-3629		1	R: fixd 270 ohm 5% 2W		
C1	0180-2805	9	1	C: fixd elect 850 uF +50-10% 75VDCW	28480	0180-2805
C2	0160-2049	1	1	C: fixd cer feedthru 5000 pF +80-20%	28480	0160-2049
C3	0180-0291	3	1	C: fixd elect 1.0 uF 10% 35 VDCW	56289	150D105X9035A2DYS
C4	0160-2049		1	C: fixd cer 5000 pF +80-20% 200VDCW	28480	0180-2805
DS1	2140-0244	4	1	Lamp: glow miniature 95V	87034	A1H
F1	2110-0012	1		Fuse: 0.5A 250V	04703	312.500
J1	1251-2357	8	1	Socket: 3-pin male power (part of rear panel)	82389	EAC-301
J2				Part of W2		
J3				Part of W3		
J4				Part of W4		
J5				Part of W5		

Operation and Service Manual
Parts and Service

Table 11 HP 8447F H64 Replaceable Parts

Ref Des	HP Part Number	CD	qty	Description	Mfr Code	Mfr Part Number
L1	9100-1618	1	2	Coil: molded choke 5.60 uH	28480	9100-1618
L2	9100-1618	1		Coil: molded choke 5.60 uH (Opt 001 and 011 only)	28480	9100-1618
MP1	08447-00005	6	1	Insulator: top cover	28480	08447-00005
MP5	08447-00082		1	Bracket: pc board support	28480	08447-00082
MP6	08447-00069		1	CATV cable assy cover	28480	08447-00069
Q1	1854-0063	7	1	Xstr: si NPN	80131	2N3055
R1	0683-2735	0	1	R: fixd comp 27 kohm 5% 1/4W	01121	CB 2735
S1	3101-2195		1	Switch-pb DPST	28480	3101-2195
S1	0590-0012	5	2	Nut: knurled 15/32-32	04009	899U-3
S2	3101-1234	3	1	Switch: slide DPDT	82389	11A-1242
T1	9100-2894	7	1	Transformer: power	28480	9100-2894
U1	5086-7767	7	1	Hybrid mc:pre-ampl 0.1-1300 MHz (Opt 001 and 011 only)	28480	5086-7767
U1	08447-60044			5086-7767 replacement kit (for use with 08447-60045 assy).	28480	08447-60044
W1	8120-1348	5	1	Cable assy: power, detachable	70903	KHS-7041
W2	08447-20043		1	Cable assy: Type-N INPUT	28480	08447-20043
W3	08447-20044		1	Cable assy: Type-N OUTPUT	28480	08447-20044
W4	08447-20051		1	Cable assy: Type-N INPUT flexible coax- ial	28480	08447-20051
W5	08447-20046		1	Cable assy: Type-N OUTPUT flexible coaxial	28480	08447-20046
XA1	1251-0135		1	Part of main deck: 15-pin connector)	2848 0	1251-0135
XF1				Fuseholder (includes the following parts)		
XF1MP1	2110-0564	8	1	Fuseholder body 12A max for UL	28480	2110-0564
XF1MP2	2110-0565	9	1	Fuseholder cap 12A max for UL	28480	2110-0565
XF1MP3	2110-0569	3	1	Nut-fuseholder thread	28480	2110-0569
XF1MP4	1400-0090	9	1	Washer: lock sst for 1/2 thread	28480	1400-0090
XQ1	0340-0664		1	Insulator: xstr mounting (TO-3)	28480	0340-0664
	0360-0368	7	1	Termination: solder stud	78189	2168-12-01
	0900-0016	8	1	O-ring 0.688" OD	00000	OBD

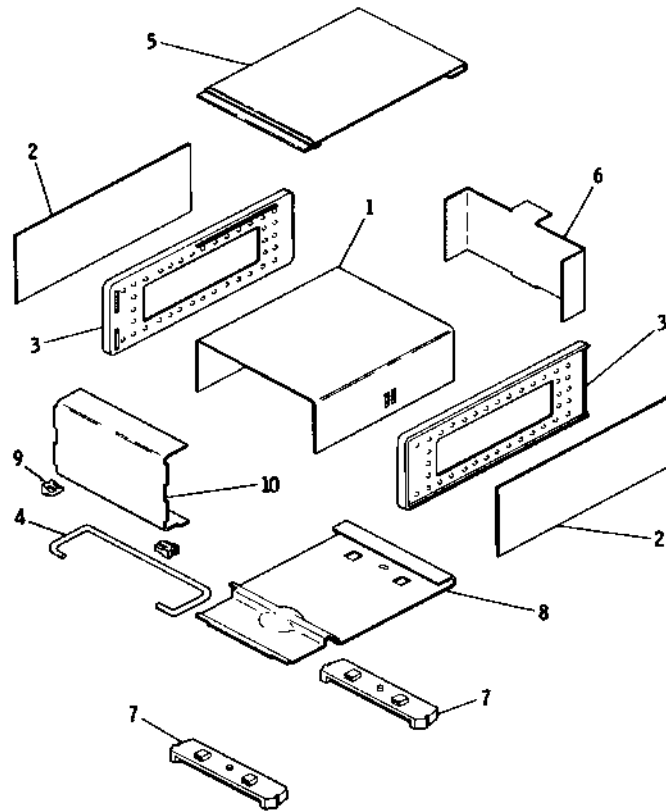

Figure 11 HP 8447D/E/F Cabinet Parts

Index Number	Part Number	CD	Description	Qty
1	08447-0029	4	Deck, main	1
2	5000-7891	8	Side cover, blue gray	
2	5000-8766	8	Side cover, olive gray	2
3	5060-0247	0	Frame assembly	2
4	1490-0031	7	Stand, tilt	1
5	5060-0708	8	Top cover, blue gray	
5	5060-8553	7	Top cover, olive gray	1
6	08447-00050	0	Panel, rear	1
7	5060-0727	1	Foot assembly	2
8	5000-0710	6	Bottom Cover, blue gray	

Operation and Service Manual
Parts and Service

Index Number	Part Number	CD	Description	Qty
8	5040-8569	9	Bottom Cover, olive gray	1
9	5040-0700	8	Hinge	1
10	08447-00070	5	Panel, front (8447D standard)	1
	08447-00071	6	Panel, front (8447D Opt 001)	1
	08447-00072	7	Panel, front (8447D Opt 010)	1
	08447-00073	8	Panel, front (8447D Opt 011)	1
	08447-00062	5	Panel, front (8447E standard)	1
	08447-00063	6	Panel, front (8447E Opt 010)	1
	08447-00074	9	Panel, front (8447F standard)	1
	08447-00075	0	Panel, front (8447F Opt 010)	1
	08447-00081		Panel, front (8447F Opt H64)	1
	08447-00040	9	Panel, front (8447D standard) mint gray	1
	08447-00041	0	Panel, front (8447D Opt 001) mint gray	1
	08447-00042	1	Panel, front (8447D Opt 010) mint gray	1
	08447-00043	2	Panel, front (8447D Opt 011) mint gray	1
	08447-00044	3	Panel, front (8447E standard) mint gray	1
	08447-00045	4	Panel, front (8447E Opt 010) mint gray	1
	08447-00046	5	Panel, front (8447F standard) mint gray	1
	08447-00047	6	Panel, front (8447F Opt 010) mint gray	1

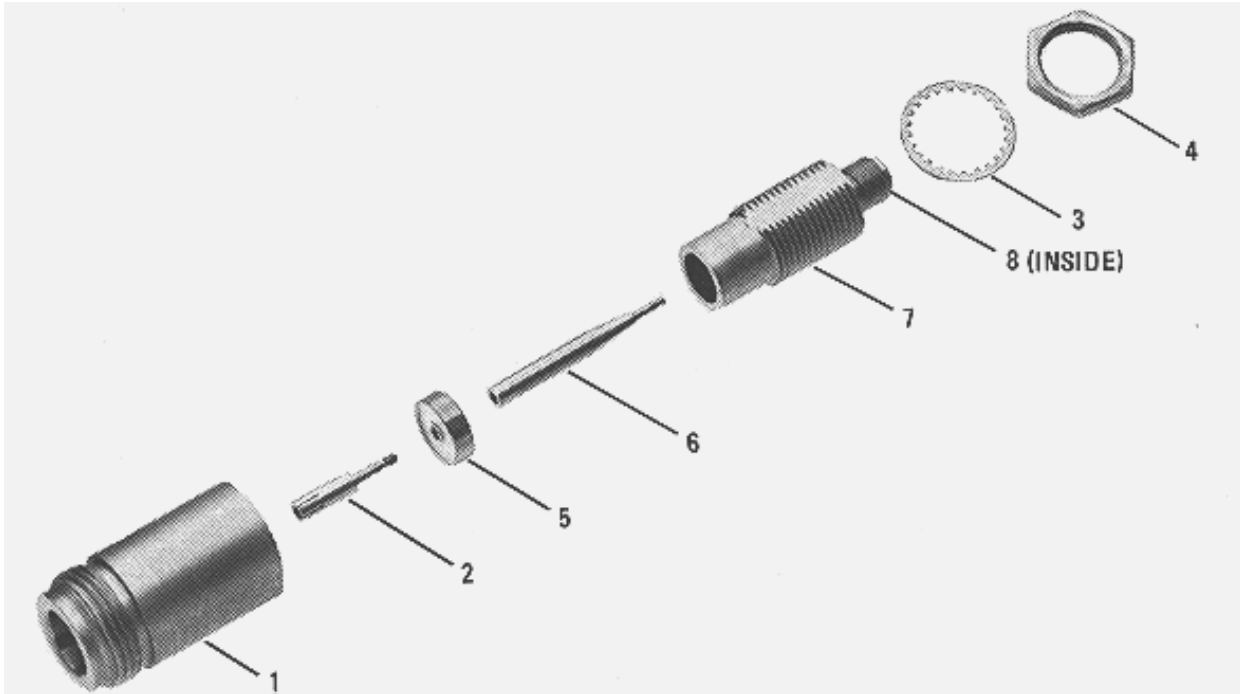

Figure 12 HP 8447D/E/F Type-N Connector (Options 010 and 011)

Index No.	Part No.	CD	Description	Index No.	Part No.	CD	Description
1	1250-0914	7	Body, RF conn	5	5040-0306	0	Insulator
2	1250-0915	8	Contact, RF conn	6	08555-20094	5	Contact, jack
3	2190-0444	1	Washer, lock	7	08555-20094	6	Body bulkhead
4	2950-0132	6	Nut, hex	8	08761-2027	4	Insulator
08559-60002			Complete assembly				

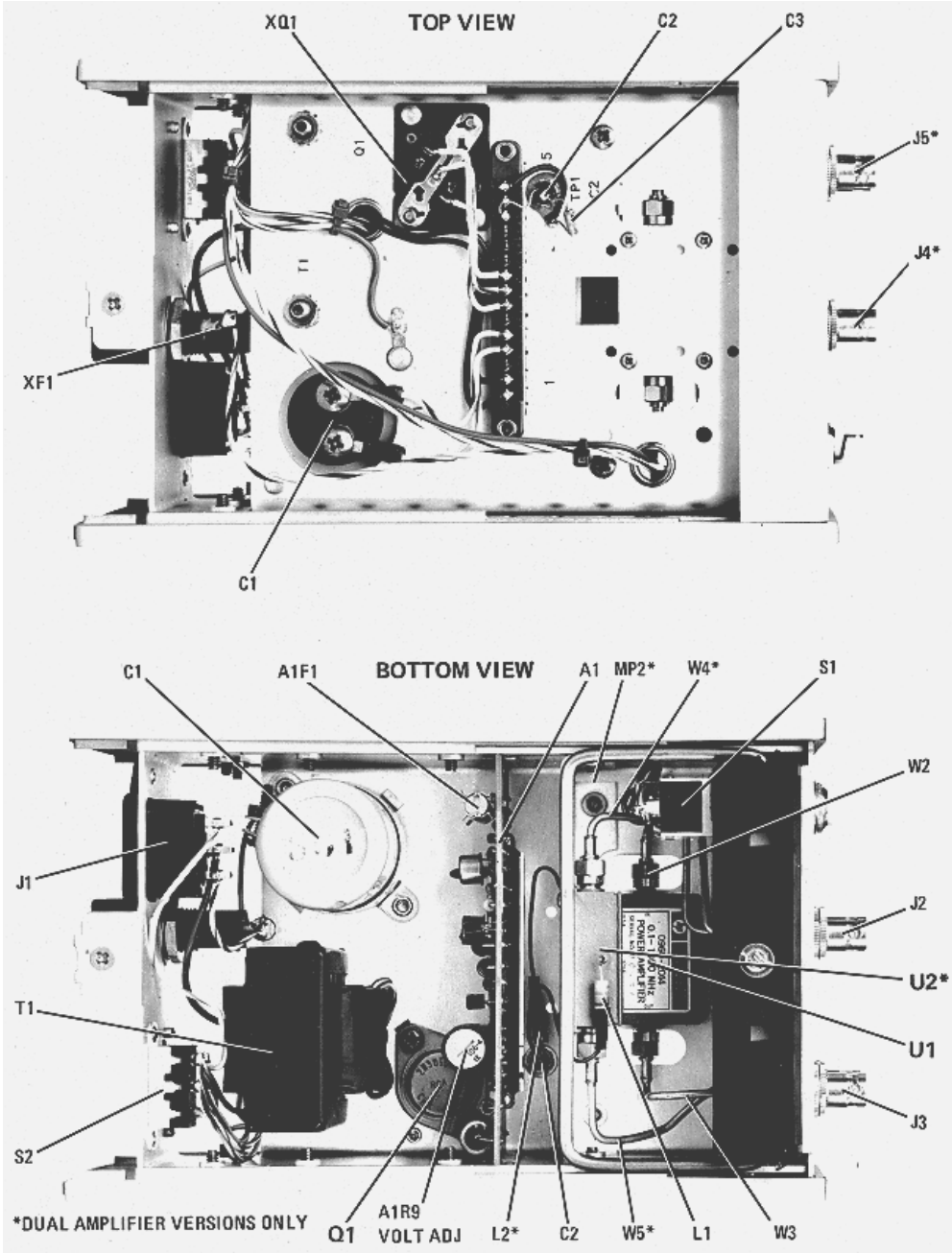

Figure 13

Internal Views

Test Equipment and Accessories Required For Troubleshooting

Test equipment and accessories required to troubleshoot the amplifier are shown in Table 4. Test instruments other than those listed may be used provided their specifications meet or exceed those listed in the table.

General Service Information

The part reference designator is the assembly designator plus the part designator. (Example: A1R9 is R9 on the A1 Power Supply Assembly.) Refer to the parts list of the desired model number for the specific component description for ordering parts.

Additional technical assistance may be obtained by contacting your local Hewlett-Packard sales and service office. Some of these offices are listed in Table 13.

WARNING: These servicing instructions are for use by qualified personnel only. To avoid electrical shock, do not perform any servicing unless you are qualified to do so.

WARNING: The opening of covers or removal of parts is likely to expose dangerous voltages. Disconnect the instrument from all voltage sources while it is being opened.

WARNING: The power cord is connected to internal capacitors that may remain live for 10 seconds after disconnecting the plug from its power supply.

Troubleshooting Procedure

First check the input and output cables. Isolate the trouble to the amplifier(s) or power supply by checking the +20 volts at XA1-14 after removing the red wire from C2. If the voltage is present, replace the amplifier (re-attach the red wire to C2). If voltage is not present or incorrect, check the power supply. The voltages shown are typical with the amplifier(s) disconnected from the power supply.

Equipment:

Digital voltmeter HP 3440A/3444A
Cable assembly (w/test clips). HP 10501A
Adapter. HP 10111A

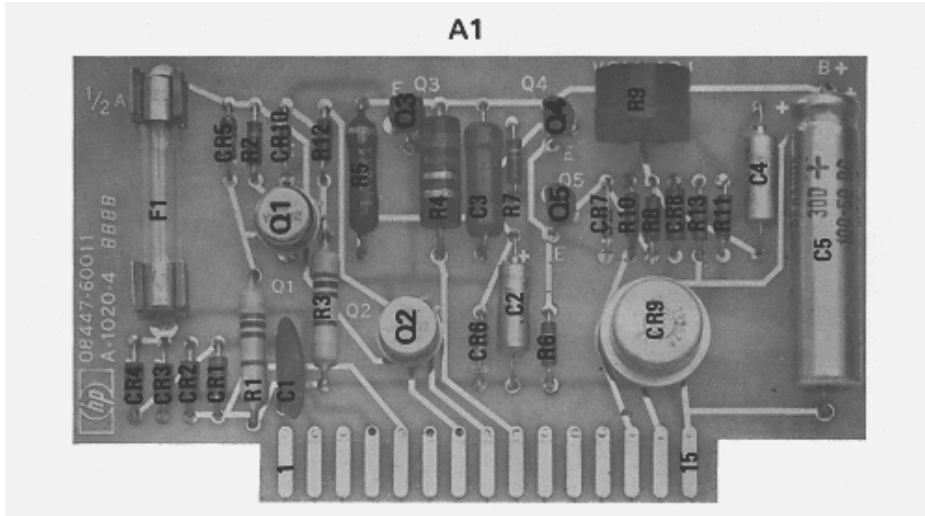

Figure 14

A1 Power Supply Component Locations, 08447-60011

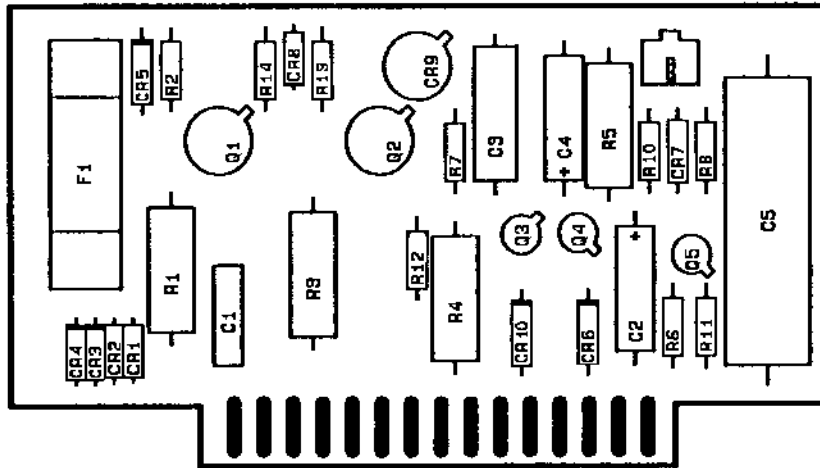

Figure 15

A1 Power Supply Component Locations, 08447-60045

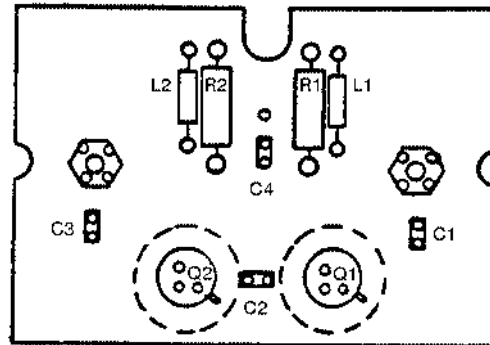

Figure 16 A2 Amplifier Board Component Locations, 08447-60038

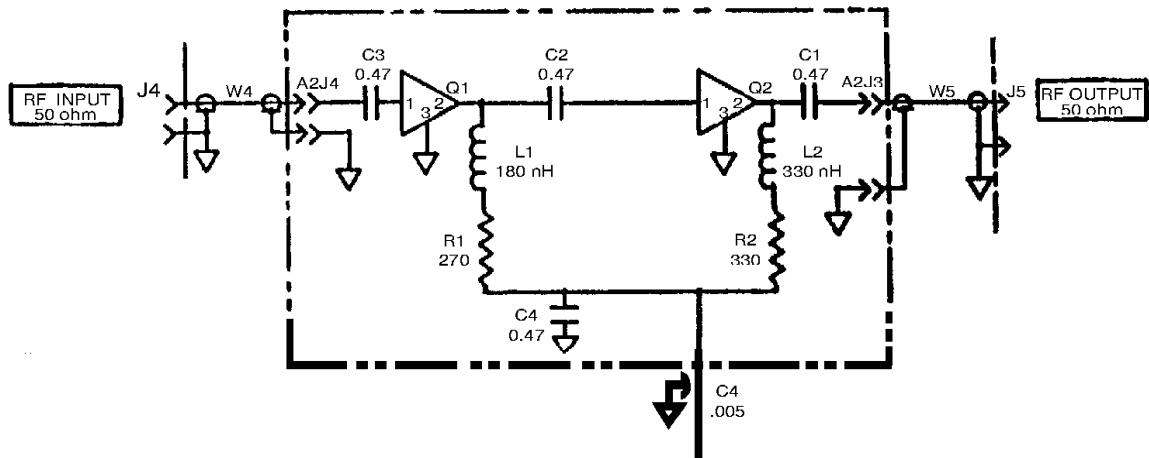

Figure 17 A2 Amplifier Board Schematic (replaces U2 on Figure 18)

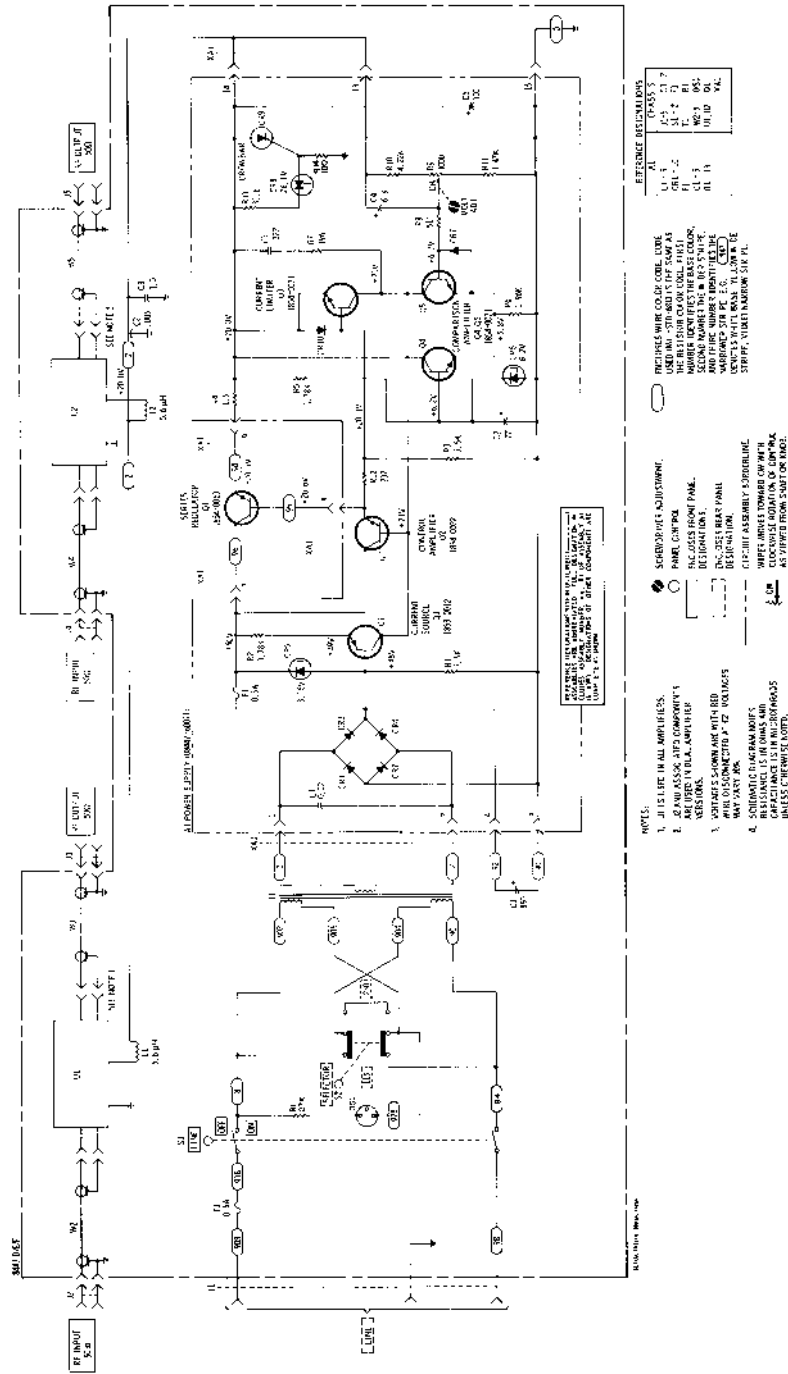

Figure 18

Amplifier and Power Supply Circuits

Manual Backdating Changes

This manual does not contain backdating information.

When backdating information is required you would adapt this manual to your instrument by making all of the manual changes listed opposite your instrument serial number in the following table. Perform these changes in the alphabetical sequence listed.

For additional important information about serial number coverage, refer to Instruments Covered By Manual.

Table 12

Manual Changes By Serial Number Prefix

Serial Prefix	Make Manual Changes