



Advanced Test Equipment Rentals
www.atecorp.com 800-404-ATEC (2832)

Model 3107B

Parallel Element E-Field Generator

User Manual



 **ETS-LINDGREN**[™]
An ESCO Technologies Company

ETS-Lindgren L.P. reserves the right to make changes to any product described herein in order to improve function, design, or for any other reason. Nothing contained herein shall constitute ETS-Lindgren L.P. assuming any liability whatsoever arising out of the application or use of any product or circuit described herein. ETS-Lindgren L.P. does not convey any license under its patent rights or the rights of others.

© Copyright 1991–2011 by ETS-Lindgren L.P. All Rights Reserved. No part of this document may be copied by any means without written permission from ETS-Lindgren L.P.

Trademarks used in this document: The *ETS-Lindgren* logo is a trademark of ETS-Lindgren L.P.

Revision Record | MANUAL,3107B | Part #399036, Rev. C

Revision	Description	Date
A	Initial Release	January, 1991
B	Edits/updates	December, 1998
C	Rebrand	February, 2011

Table of Contents

Notes, Cautions, and Warnings	v
1.0 Introduction	7
Tripod Options	8
ETS-Lindgren Product Information Bulletin	9
2.0 Maintenance	11
Replacement and Optional Parts	11
Service Procedures	11
3.0 Specifications	13
Electrical Specifications	13
Physical Specifications (Assembled)	13
Typical Power Requirements at One-Meter.....	14
Typical Test Setup: Power Requirements	15
Typical Input Voltage Requirements at One-Meter.....	16
Typical Test Setup: Input Voltage Requirements	17
Schematic for Model 3107B.....	18
4.0 Assembly and Operation	19
Appendix A: Warranty	21

This page intentionally left blank.

Notes, Cautions, and Warnings

	<p>Note: Denotes helpful information intended to provide tips for better use of the product.</p>
<p>CAUTION</p>	<p>Caution: Denotes a hazard. Failure to follow instructions could result in minor personal injury and/or property damage. Included text gives proper procedures.</p>
<p>WARNING</p>	<p>Warning: Denotes a hazard. Failure to follow instructions could result in SEVERE personal injury and/or property damage. Included text gives proper procedures.</p>



See the ETS-Lindgren *Product Information Bulletin* for safety, regulatory, and other product marking information.

This page intentionally left blank.

1.0 Introduction

The wide band design of the **ETS-Lindgren Model 3107B Parallel Element E-Field Generator** allows operation over the entire 10 kHz to 30 MHz frequency range in two bands: Band 1 covers the frequency range from 10 kHz to 5 MHz, and Band 2 covers 5 MHz to 30 MHz.

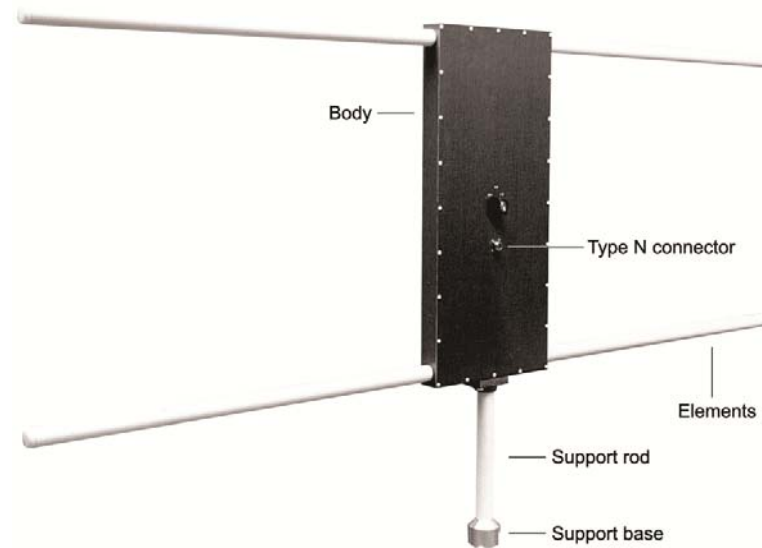

For portability, the Model 3107B elements are easily attached and removed. Attach each the element by rotating it clockwise into the Model 3107B body until it is firmly connected; to disassemble, rotate each element counterclockwise.

Tripod Options

The Model 3107B includes a tripod mount that can be attached to a standard tripod. ETS-Lindgren offers the following non-metallic, non-reflective tripods for use at both indoor and outdoor EMC test sites.

- **4-TR Tripod**—Constructed of linen phenolic and delrin, designed with an adjustable center post for precise height adjustments. Maximum height is 2.0 m (80.0 in), and minimum height is 94 cm (37.0 in). This tripod can support up to an 11.8 kg (26.0 lb) load.



- **7-TR Tripod**—Constructed of PVC and fiberglass components, providing increased stability for physically large antennas. The unique design allows for quick assembly, disassembly, and convenient storage. Allows several different configurations, including options for manual or pneumatic polarization. Quick height adjustment and locking wheels provide ease of use during testing. Maximum height is 2.17 m (85.8 in), with a minimum height of 0.8 m (31.8 in). This tripod can support a 13.5 kg (30 lb) load.



ETS-Lindgren Product Information Bulletin

See the ETS-Lindgren *Product Information Bulletin* included with your shipment for the following:

- Warranty information
- Safety, regulatory, and other product marking information
- Steps to receive your shipment
- Steps to return a component for service
- ETS-Lindgren calibration service
- ETS-Lindgren contact information

This page intentionally left blank.

2.0 Maintenance

CAUTION

Before performing any maintenance, follow the safety information in the ETS-Lindgren *Product Information Bulletin* included with your shipment.



Maintenance of the Model 3107B is limited to external components such as cables or connectors.

If you have any questions concerning maintenance, contact ETS-Lindgren Customer Service.

Replacement and Optional Parts



ETS-Lindgren may substitute a similar part or new part number with the same functionality for another part/part number. Contact ETS-Lindgren for questions about part numbers and ordering parts.

Following are the part numbers for ordering replacement or optional parts for the Model 3107B.

Part Description	Part Number
Support Rod	101948
Support Base	101942B

Service Procedures

For the steps to return a system or system component to ETS-Lindgren for service, see the *Product Information Bulletin* included with your shipment.

This page intentionally left blank.

3.0 Specifications

Electrical Specifications

Frequency Range:	10 kHz–30 MHz <ul style="list-style-type: none">• Band 1: 10 kHz–5 MHz• Band 2: 5 MHz–30 MHz
Input Impedance:	50 Ohms
Field Pattern:	At one meter on centerline the field is a linearly polarized, essentially homogenous E-field.
E-Field Capability:	See tables on page 14 and page 16.
Maximum Power Capability:	1000 Watts
Connector:	Type N

Physical Specifications (Assembled)

Length:	184.15 cm (72.5 in)
Width (Element Separation):	60.96 cm (24.0 in)
Height:	5.08 cm (2.0 in)
Weight:	5.44 kg (12.0 lb)

Typical Power Requirements at One-Meter

See typical test setup on page 15.

FREQ (kHz)	FIELD STRENGTH					
	1v/m	10v/m	20v/m	50v/m	75v/m	100v/m
	WATTS	WATTS	WATTS	WATTS	WATTS	WATTS
10	1	5	15	35	75	200
50	1	5	15	50	120	320
100	1	5	15	50	125	255
250	1	5	15	45	120	220
500	1	5	15	45	115	220
1000	1	5	15	45	120	370
Band	1	5	15	45	120	370
Switched	1	15	45	130	290	*
Point	30	60	210	400	*	*
7000	30	60	210	400	*	*
10000	15	30	90	330	490	500
12000	17	35	115	250	440	*
14000	15	30	100	120	230	*
16000	15	30	130	180	240	*
18000	1	5	20	60	250	*
20000	1	5	15	70	240	300
22000	15	30	100	200	240	300
24000	7	15	60	200	500	*
26000	6	20	80	350	*	*
28000	15	40	130	*	*	*
30000	12	30	110	*	*	*

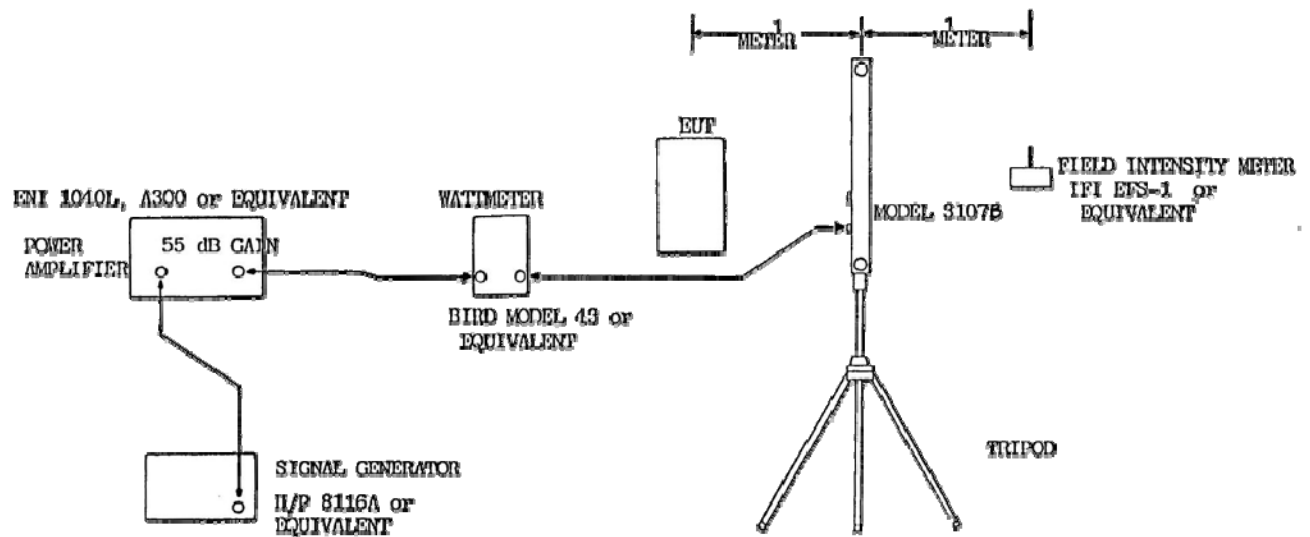

TYPICAL TEST SETUP: POWER REQUIREMENTS

Typical Input Voltage Requirements at One-Meter

See typical test setup on page 17.

	FREQ	FIELD STRENGTH					
		1v/m	10v/m	20v/m	50v/m	75v/m	100v/m
	10 kHz	3.4V	52.5V	137.2V	250.0V	280.0V	320.0V
	20	3.3	39.2	90.0	229.0	265.0	300.0
	30	3.3	35.0	81.0	187.8	260.0	280.0
	40	3.5	33.6	70.2	165.8	259.0	285.0
	50	3.9	35.3	70.1	159.0	214.0	260.0
	60	3.9	36.2	69.9	159.7	221.0	282.0
	70	3.8	36.7	70.3	153.5	222.0	280.0
	80	3.5	36.3	69.9	149.6	221.3	278.4
	90	3.6	35.8	70.5	155.2	222.5	276.5
	100	3.5	35.7	69.7	156.3	222.2	276.5
	200	3.4	35.5	68.4	144.4	197.6	293.4
	300	3.4	33.0	62.2	139.3	193.7	302.5
	400	3.4	31.1	63.1	143.1	188.2	327.1
	500	3.2	31.3	62.1	141.3	190.5	329.5
	600	3.2	31.2	61.9	137.8	197.8	325.8
	700	3.1	31.1	61.3	135.4	204.4	320.7
	800	3.0	30.8	60.6	133.8	208.9	320.0
	900	3.0	30.5	60.6	132.6	211.6	321.9
	1 MHz	3.0	30.5	60.7	130.1	211.8	311.5
Band	2	2.8	30.3	58.7	135.6	202.8	305.8
Switch	4	2.5	25.9	52.7	131.5	207.5	*
Point	6	4.9	52.1	64.0	210.0	*	*
	8	5.4	62.8	88.0	204.5	*	*
	10	4.4	44.7	91.0	185.0	220.0	310.0
	15	1.5	17.0	32.8	85.3	125.9	*
	20	1.5	15.8	30.7	67.1	95.7	350.0
	25	0.2	2.7	5.65	30.0	40.0	*
	30	1.2	15.1	29.3	58.7	150.0	*

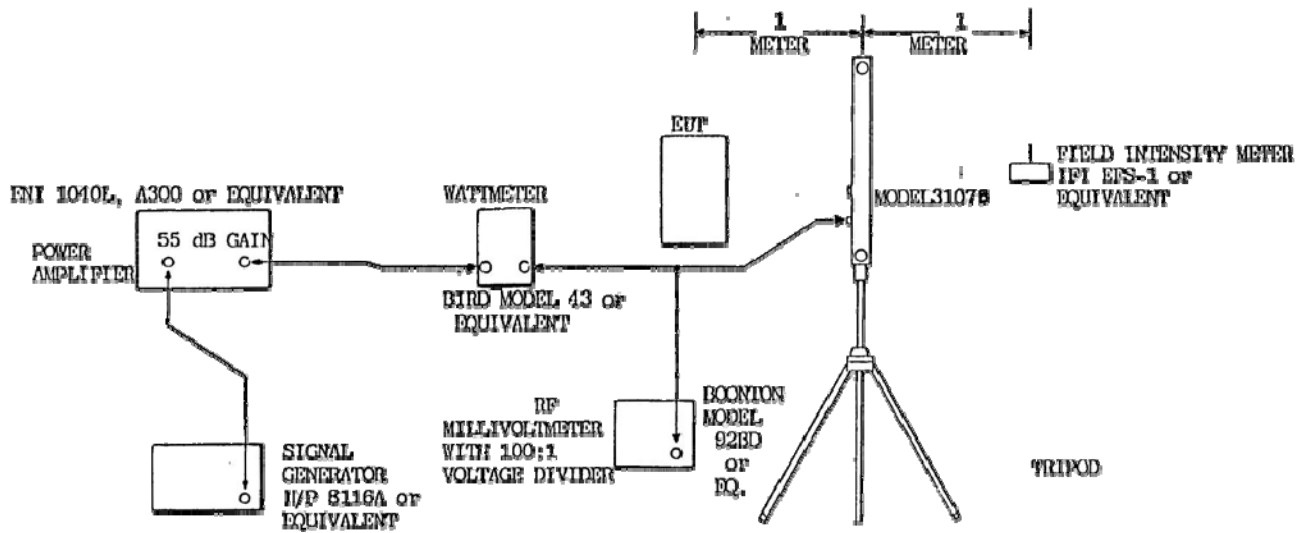

TYPICAL TEST SETUP: INPUT VOLTAGE REQUIREMENTS

Schematic for Model 3107B

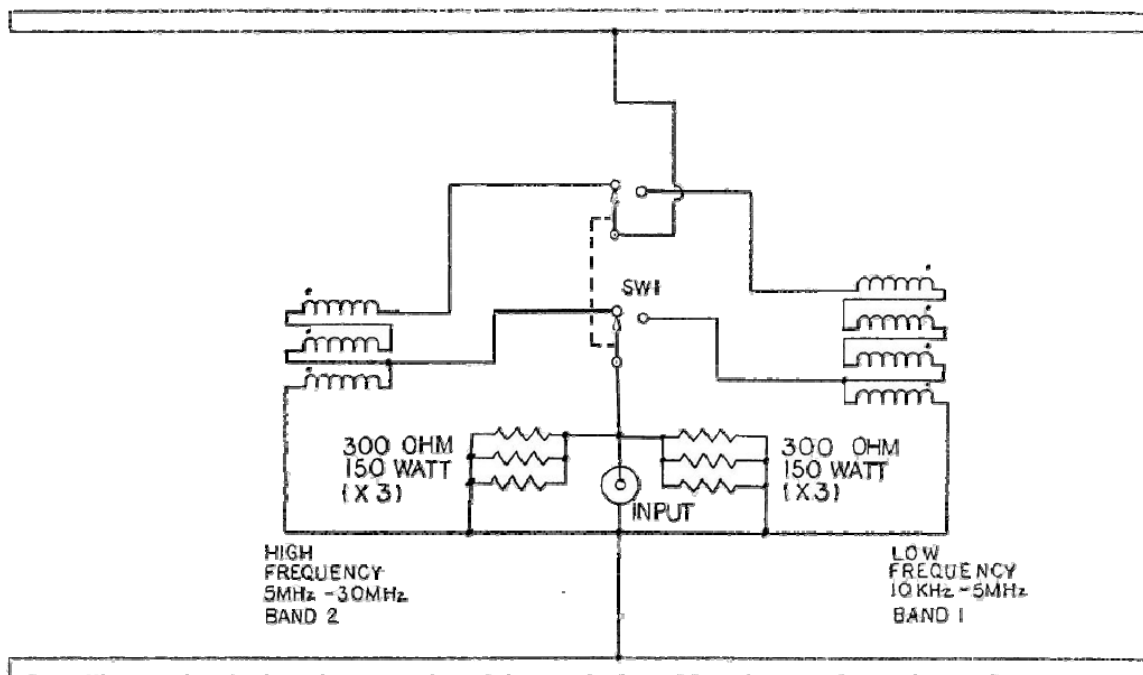

4.0 Assembly and Operation

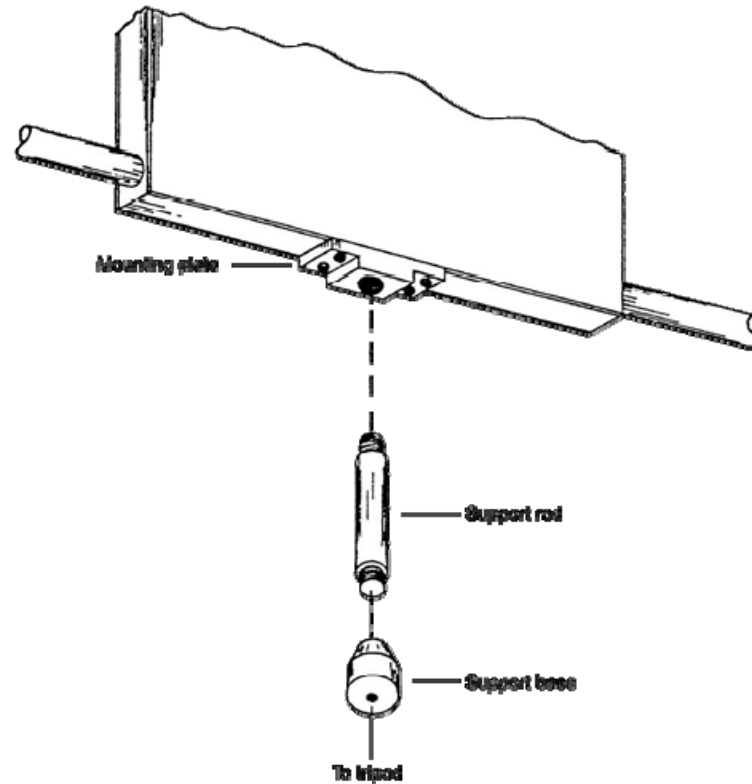

1. Attach the support rod to the mounting plate on the bottom of the Model 3107B Parallel Element E-Field Generator by rotating it clockwise into the plate until it is firmly connected.
2. Attach the support base to the support rod by rotating it clockwise onto the rod until it is firmly connected.
3. Attach the Model 3107B assembly to a standard tripod (not included) by rotating the support base clockwise onto the connector on the tripod.

4. Attach the signal source to the Type N connector on the Model 3107B.

Use a voltage monitor or power monitor at the signal source to determine the input voltage/power applied. The field strength capability is shown in the tables on page 14 and page 16. A field intensity monitor on the opposite side of the Model 3107B from the test sample and at the corresponding distance will give a good approximation of the field seen by the sample.

Appendix A: Warranty



See the *Product Information Bulletin* included with your shipment for the complete ETS-Lindgren warranty for your Model 3107B.

DURATION OF WARRANTIES FOR MODEL 3107B

All product warranties, except the warranty of title, and all remedies for warranty failures are limited to one year.

Product Warranted	Duration of Warranty Period
Model 3107B Parallel Element Field Generator	1 Year