

PV350 English Instruction Sheet
Page 1

FLUKE®

PV350

Pressure/ Vacuum Transducer Module

Instruction Sheet

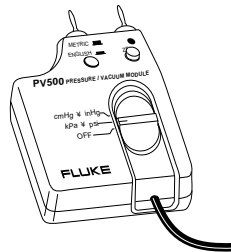

Introduction

The PV350 Pressure/Vacuum Transducer Module (the module) measures gauge pressure; the difference between atmospheric (barometric) pressure and the pressure (or vacuum) applied to the pressure port on the transducer. It then converts that measurement to 1 mV dc per unit. A module and a high-performance digital multimeter (DMM) with min/max function become a datalogger capable of measuring peak high and peak low.

Box Contents

- Pressure/Vacuum Transducer Module
- 1/4 -inch male flare to 1/4-inch female pipe thread connector
- 9V battery
- Storage tray
- Instruction Sheet, Quick Reference guide, and warranty card

Safety Information

WARNING

To avoid eye injury, always wear approved safety glasses when working with this instrument.

To avoid injury from pressure explosion:

- **Be sure that pressure is removed before disconnecting any hoses or tubing from the PV350 transducer.**
- **Follow accepted safety procedures for systems on which pressure or vacuum measurements are made.**
- **Make sure the PV350 is serviced by a qualified technician.**



Safety Standards: Complies with test pressure requirements of ANSI/ISA S82.03-1988, Protection Class III per IEC 1010-1-1990, Annex H.

PN 926873 May 1992 Rev. 4, 9/97

© 1999 Fluke Corporation, All rights reserved. Printed in U.S.A.

All product names are trademarks of their respective companies.

This module has been designed and tested in accordance with IEC Publications 348 and 1010. To ensure that the module is used safely, follow all safety and operating instructions in this Instruction Sheet. If the module is not used as described in this Instruction Sheet, the safety features of the module might be impaired.

Do not use the module if the module or fittings look damaged, or if you suspect that the module is not operating properly.



This symbol on the module indicates that an operator should refer to an explanation in the instruction sheet.

Follow accepted safety procedures for the systems on which pressure or vacuum measurements are being made.

Materials Compatibility

The PV350 is compatible with industrial gases and liquids that are compatible with 316 stainless steel. To determine the compatibility of a liquid or gas, refer to the manufacturer's specifications. When making measurements on more than one type of pressure system, make sure the fluids or gases in those systems are compatible. If they are not, contamination or damage to the system being measured may result.

Cleaning

Clean the module using a soft cloth and mild soap and water. Do not immerse the PV350 in liquids.

Clean the transducer and connectors after each use with a cleaner appropriate for the liquid or gas connected during measurement. Refer to the manufacturer's instructions for the proper cleaning material.

Measuring Pressure and Vacuum

Caution

The sensor diaphragm can be damaged by solid or sharp objects. Never insert any object into the inlet port.

Clean the sensor immediately after use with appropriate solvents (refer to the solvent manufacturer's instructions).

NOTE

Fluke recommends that teflon sealing tape (or its equivalent) be used in fitting threads to ensure good seals between the PV350 and any hoses or fittings.

1. Plug the PV350 into the DMM (red polarity dot to volts input) and set the multimeter to mV dc.
2. Check the battery voltage (see Testing the Battery).
3. Press the English/Metric button to select the desired units.
4. Slide the switch to the desired setting.
5. Before applying pressure, zero the module by turning the ZERO potentiometer until the DMM displays zero. (Zero on the range you will be using and rezero the DMM whenever the scale is changed.)

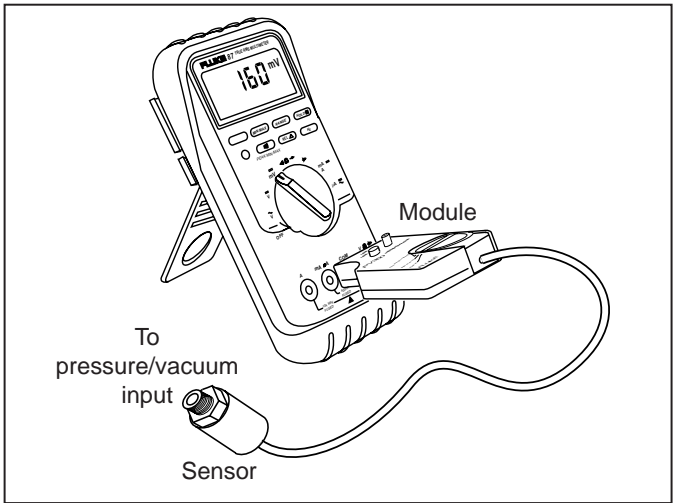

Figure 1. Operation

NOTE

The Relative or Zero function on your DMM (if available) can be used instead of the ZERO potentiometer to zero the meter. Refer to the multimeter's user manual for instructions on using this function. Zeroing the meter does not affect the module's specified accuracy.

6. Apply pressure/vacuum to the PV350 and read the DMM display.
 - When measuring pressure, if the DMM displays OL, switch the multimeter range from millivolts to dc volts. Increasing the range to dc volts moves the decimal position three places to the left (500 psi displays as 0.500V).
 - When measuring vacuum the DMM displays a minus sign.

Testing the Battery

1. Turn the DMM and the module OFF and connect the PV350 to the DMM.
2. Turn the DMM on and set the DMM to the mV dc range.
3. If the DMM displays less than 100 mV, replace the battery.

How to Replace the Battery

WARNING

TO AVOID ELECTRICAL SHOCK, DISCONNECT THE MODULE FROM ALL DEVICES BEFORE OPENING THE CASE. BE SURE TO COMPLETELY REASSEMBLE THE MODULE BEFORE ATTEMPTING TO USE IT.

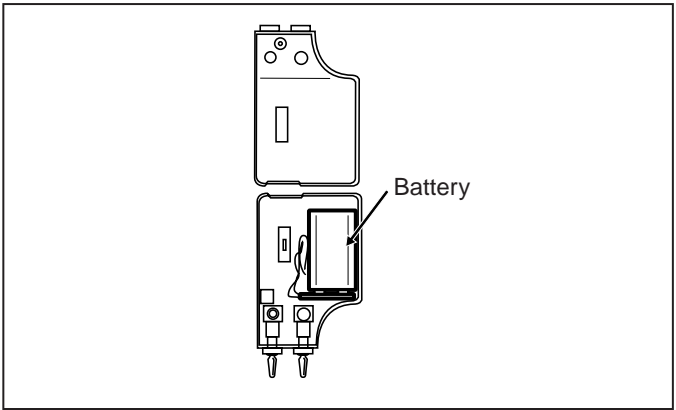
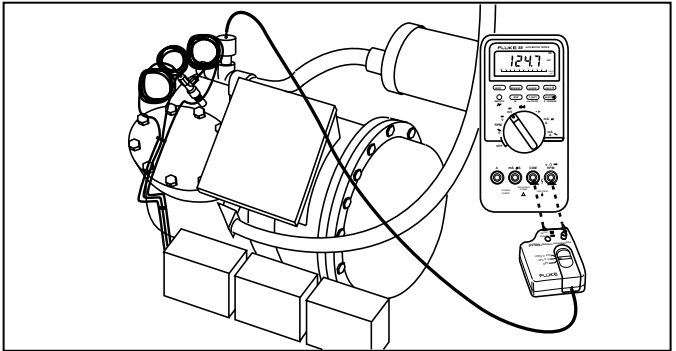

Figure 2. Battery Replacement

1. Turn the module OFF and unplug it from the DMM.
2. Remove the screw from the back of the module, separate the case, and replace the battery.
3. To reassemble, line up the holes in the case with the metric/english switch and zero knob. Then snap the two halves together. Reinstall the screw.

Typical Applications



Pressure for HVAC/R Super Heat Measurements

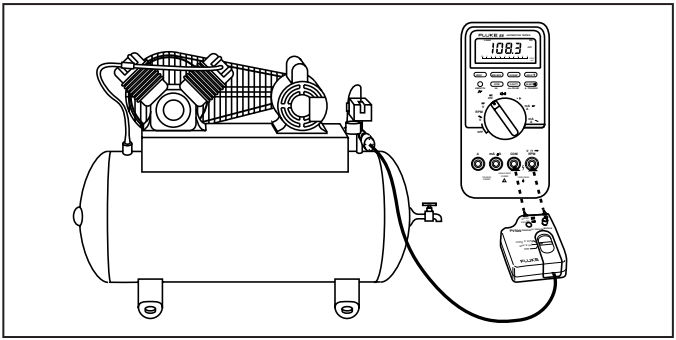

Measure Pneumatic Pressures

psi = inches of H ₂ O x (3.6127 x 10 ⁻²)	inches of H ₂ O = psi x 27.68
psi = mm of H ₂ O x (1.4223 x 10 ⁻³)	mm of H ₂ O = psi x 703.1
psi = cm of H ₂ O x (14.223 x 10 ⁻³)	cm of H ₂ O = psi x 70.3
psi = bar x (14.503)	bar = psi x 0.0689
psi = lbs/ft ² x (6.9444 x 10 ⁻³)	lbs/ft ² = psi x 144
psi = mbar x (1.4503 x 10 ⁻²)	mbar = psi x (68.9513)
psi = Pascals x (1.4503 x 10 ⁻⁴)	Pascals = psi x (6.895 x 10 ³)

All H₂O conversion factors are @ 4°C

Conversion Factors

How to Calibrate the PV350

Calibrate the PV350 yearly to ensure that it meets its performance specifications.

Table 1. Recommended Equipment

Instrument	Minimum Specification	Recommended Model
Precision Pressure Reference	500 psi, 0.25% of reading accuracy	Crystal Engineering inHg/PSIG Multical or equivalent
Pressure Source	Nitrogen gas bottle with pressure regulator, >750 psi	Tescom pressure regulator Model 44-2214-24 1V
DMM	0 to 500 mV (minimum) with 0.1 mV resolution 10 MΩ input impedance	Fluke 45 or equivalent

1. Allow the PV350 to stabilize at room temperature, away from drafts, for at least 30 minutes. Turn on the DMM and, if required by its operating instructions, allow it to warm up as indicated.

2. Connect the pressure regulator to the nitrogen bottle and the reference pressure gauge to the pressure regulator. The nitrogen bottle must have >750 psi.
3. Verify the condition of the battery and if necessary, replace the battery. (Refer to Figure 2.)
4. Remove the top cover of the module and connect it to the mV input of the DMM. Set the scale to measure 500 mV (0.1 mV resolution).
5. Turn on the PV350 and allow it to warm up for two minutes.
6. Set the PV350 to the psi range.
7. Center the ZERO potentiometer, R3 (see Figure 3). Remove the knob from R3 and insert it into R4 (the coarse zero adjustment). With no pressure applied, set the reading to $0V \pm 0.0003V$. Insert the knob back into R3, and adjust the final reading to $0.0000V, \pm 0.0001V$.

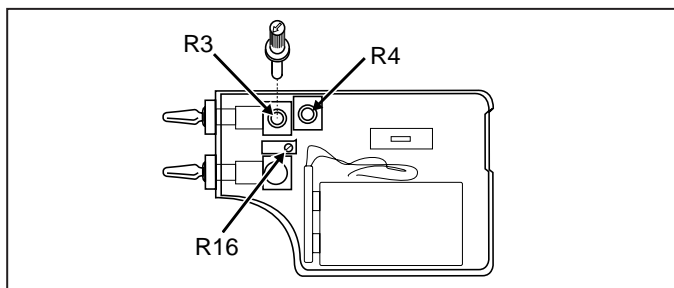

Figure 3. Calibration Adjustment Points

8. Connect the sensor to the pressure reference and nitrogen bottle pressure calibration system.
9. Adjust the pressure regulator to about 250 psi. The readings on the reference pressure gauge and the reading from the PV350 should agree within $\pm 0.1\%$ of the point, ± 0.3 psi: approximately $\pm 0.0006V$ or ± 0.6 psi. Adjust R16 as necessary.
10. Adjust the pressure regulator to about 350 psi. The readings on the reference pressure gauge and the PV350 should agree within $\pm 0.1\%$ of the point, ± 0.3 psi: approximately $\pm 0.0007V$ or ± 0.7 psi. If necessary, adjust R16 to bring the reading into specification and recheck the 250 psi point. It may be necessary to repeat steps 9 and 10 until both points are within specification.
11. Reduce pressure to zero and switch the module OFF.

How to Verify Calibration

1. Connect the sensor (transducer) to a pressure calibration standard, and plug the module into the DMM.
2. Be sure the system is vented, then zero the module.
3. Enter the pressure settings shown in Table 2 and check for the indicated readings

NOTE

To save time, verify each reading (psi, kPa, cm of Hg, and inches of Hg) before changing the pressure setting.

Table 2. Readings in mV

Setting (in psi)	psi*	kPa	cm-Hg	Inches-Hg
0	-0.1 to +0.1	-2.1 to +2.1	-1.6 to +1.6	-0.6 to +0.6
125	123.4 to 126.6	--	--	--
350	346.2 to 353.8	2386.8 to 2439.2	1790.4 to 1829.7	704.9 to 720.3

*Zero the module before making psi measurements. Do not re-zero when switching to check kPa, cm-Hg, or in-Hg readings.

Specifications

The following specifications apply at 23 ±5°C for 1 year after calibration when the module is zeroed prior to each measurement.

Pressure

Range	Accuracy
to 350 psig (3.447 to 2413 kPa)	±1% of reading ±0.3 psig (±1% ±2.1 kPa)
350 to 500 psig (2413 to 3447 kPa)	±5% of reading ±1 psig typical (±5% ±7.0 kPa)

Vacuum

Range	Accuracy
0 to 29.9 in-Hg (0 to 76 cm-Hg)	±1% of reading ±0.5 in-Hg (±1% of reading ±1.3 cm-Hg)

Output: 1 mV per unit (psi, kPa, cm-Hg or in-Hg)

Resolution: 0.1 psi/in-Hg in mV range, 1 psi/in-Hg in Volt range with 3 1/2- or 4-digit meters.

RFI Specification: Typically < 1% error from 14 kHz to 30 MHz at 1 V/M.

Meter Input Impedance: 10 MΩ (For input impedance of 1M Ω , add 0.5% to basic accuracy specification.)

Maximum working pressure: 500 psi.

Burst Pressure: 1000 psi.

Storage Temperature: -51 to 71°C

Operating Environment

Temperature	Humidity
-10 to 10 ·C	Uncontrolled Humidity
10 to 30 ·C	0 to 95% Relative Humidity
30 to 40 ·C	0 to 75% Relative Humidity
40 to 50 ·C	0 to 45% Relative Humidity
50 to 55 ·C	0 to 35% Relative Humidity

Temperature Derating: (Add to Basic Accuracy Specification.
°C = ambient temperature)

Temperature Range	Derating
28· to 55·C	0.016% x (·C - 28)
18· to 28·C	No derating
0· to 18·C	0.048% x (18 - ·C)
-10· to 0·C	0.264% x (9· - ·C)

General

Weight: 12 oz, (336 grams)

Battery: Standard 9V battery (NEDA #1604, 6F22, 006P)

Battery Life: 300 hours (typical) for Carbon-zinc 400 hour (typical) for Alkaline

Vibration: 3g @ 55 Hz

Shock: 1 meter drop

Electrical Cable: Black PVC, will withstand up to 105·C

Cable Length: 8 feet

Pressure Port Connection: 1/4 inch NPT

Connector: Brass 1/4-in male flare to 1/4-in female pipe thread

Table 3. List of Replaceable Parts

JF PN	Description
446823	Battery, Primary, 9V, 0-15 mA
650903	Case Bottom, PV350
919790	Case Top, PV350
913207	Fitting, BR, SAE, 45, 1/4 FP
926873	PV350 Instruction Sheet
926881	PV350 Quick Reference Guide
927009	Replacement Cable Assembly

For application or operation assistance or information on Fluke products, call:

800-44-FLUKE (800-443-5853) in U.S.A. and Canada

31 40 723-220 in Europe

206-356-5500 from other countries

The phone number for replacement parts is 1-800-526-4731

Fluke Corporation
P.O. Box 9090
Everett, WA
98206-9090

Fluke Europe B.V.
P.O. Box 1186
5602 B.D.
Eindhoven
The Netherlands