



XM-T1200

Camera, Probe x2, and Stage Marker



SPECIFICATIONS

Model	XM-T1200	
Type	Measuring unit (2 probes) XM-T1200/M1200/S1200	
Camera	Image pickup device	4 megapixel CMOS image sensor
	Wavelength at light receiving center	Near-infrared
Measuring range	600 mm × 300 mm × 200 mm 23.62" × 11.81" × 7.87"	
Min. display unit	Distance	1 μm
	Angle	0.0001 degrees
Measurement accuracy	Repeatability	Stage locked: ±3 μm Stage unlocked: ±4 μm
	Indication error	Stage locked: ±8 μm ^{*1} Stage unlocked: ± (10 + L/100) μm ^{*2}
Stage	Withstand load	25 kg
	X-axis movable range	±100 mm ±3.94"
	Rotation range	±60°
Probe	No. of probes	2
Stage marker	No. of markers	6
	Marker light source	Near-infrared LED (870 nm)
Probe connection port	2 inputs	
Console input	Dedicated console	
External remote input	Non-voltage input (with and without tangent point): 2 inputs	
Interfaces	Communication (external communication)	USB 2.0 Series A: 3 ports
Display	Built-in display	15" LCD monitor (1024 × 768)
Environmental resistance	Ambient temperature	+10 to +35 °C 50 to 95 °F
	Relative humidity	20 to 80 % RH (No condensation)
Power supply	Power supply voltage	Supplied from controller
	Connector type	Dedicated connector
Weight	Head: Approx. 39.6 kg (including camera and cable) Console: Approx. 150 g (including cable)	
^{*1} In reference to ISO 10360-2 (within the range of 200 × 200 × 150 mm 7.87" × 7.87" × 5.91" at an operating ambient temperature of 23 ±1°C 73.4 ±1.8°F) ^{*2} In reference to ISO 10360-2 (within the range of 500 × 200 × 150 mm 19.69" × 7.87" × 5.91" at an operating ambient temperature of 23 ±1°C 73.4 ±1.8°F)		

Dimensions

* Download CAD file or product manual for larger image/text and more detail.

XM-1200_T1200_dimension_01.gif

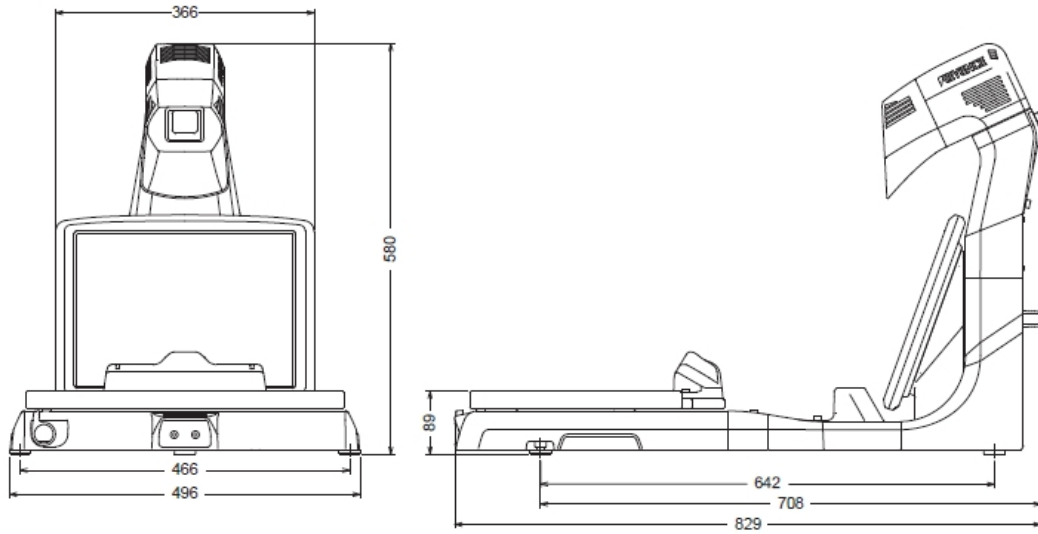

XM-1200_T1200_dimension_02.gif

