

## PLZ-3W/3WH series

### ELECTRONIC LOAD (CC·CR·CV·CP)



**Four types of power rating: 150W,300W,600W,and 1000W, a total of eight models**  
**Ready for constant current, constant resistance, constant voltage, and constant power modes**  
**Capable of doing actual-load simulations under sequence control**  
**Maximum input voltage of 500V(PLZ-3WH Series)**

### Outline

The PLZ-3W/3WH Series are composed of system electronic loads used either in characteristic or lifetime tests of a variety of DC voltage sources such as switching power supplies and primary and secondary batteries, or as burn in loads. Instruments in the PLZ-3W Series have four operation modes: “constant current”, “constant resistance”, “constant voltage”, and “constant power”. They are also available in four different power ratings, 150 W, 300 W, 600 W, and 1000 W, with a total of eight models available overall. Incorporating a high-performance current control circuit, all instruments provide highly stable, high-speed operation and offer improved operability and multi-functionality through the use of CPU control. These features allow them to simulate actual load tests of power supply units having large transitional changes in their output currents, such as printers and motors. In the constant power mode,

these instruments deliver performance in carrying out load tests on alkaline and other types of batteries. Furthermore, the PLZ-3WH Series accept DC input voltages of up to 500 V, making it ready for use at high voltages. And when an optional GPIB or RS-232C interface is employed, these instruments can be operated by fully programmable control. In particular, take advantage of a Kikusui-designed multi-channel bus (MCB) to simultaneously control a maximum of 16 instruments per GPIB address or RS-232C port. (Note: In addition to the PLZ-3W/3WH series, this MCB will also handle PAX Series programmable power supplies and PBX Series bipolar power supplies.)

# PLZ-3W/3WH series

## ELECTRONIC LOAD (CC·CR·CV·CP)

### Front Panel

PLZ303WH

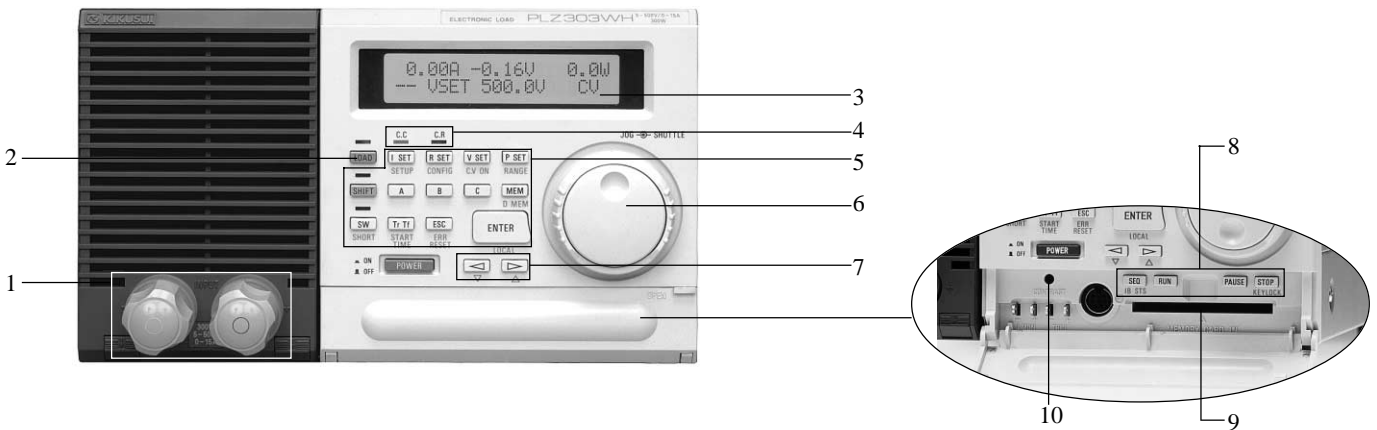

- |  |  |
|--|--|
| <p>1 Load terminals on the front panel<br/>Used to connect to the device being tested. They are connected in parallel to the load terminals on the rear panel. (Note that PLZ603W/603WH and PLZ1003W/1003WH have no load terminals on the front panel.)</p> <p>2 LOAD key<br/>Turns on/off current that flows through the instrument.</p> <p>3 Screen (LCD with back light)<br/>Displays the set values of current, resistance, voltage, and power; menu items; and a variety of parameters and messages.</p> <p>4 Constant current (C.C) / constant resistance (C.R) lamps<br/>Indicate whether the instrument is in C.C or C.R mode.</p> <p>5 Function keys<br/>Used to select each mode, or to set memories or rise/fall time.</p> <p>6 JOG/SHUTTLE knobs<br/>The JOG knob is used for fine adjustments to set values or to select values, and the SHUTTLE knob is used for coarse adjustments to set values.</p> | <p>7 Arrow keys<br/>Used to select a menu, setting item, or a step number for program editing in the sequence mode.</p> <p>8 Sequence keys<br/>Menu keys for sequence mode</p> <p>9 Memory card slot<br/>An optional memory card (SMC-32) is inserted here.</p> <p>10 Contrast control</p> <p>11 Optional board slot<br/>An optional interface board (one of GPIB, RS-232C, and MCB) is inserted here.</p> <p>12 Remote sensing terminals<br/>Used for remote sensing that compensates for the voltage drop caused by resistance in load cabling.</p> <p>13 External control connector</p> <p>14 Load terminals</p> <p>15 AC input supply voltage range selector switch (on the bottom face)</p> |
|--|--|

### Rear Panel

PLZ303WH

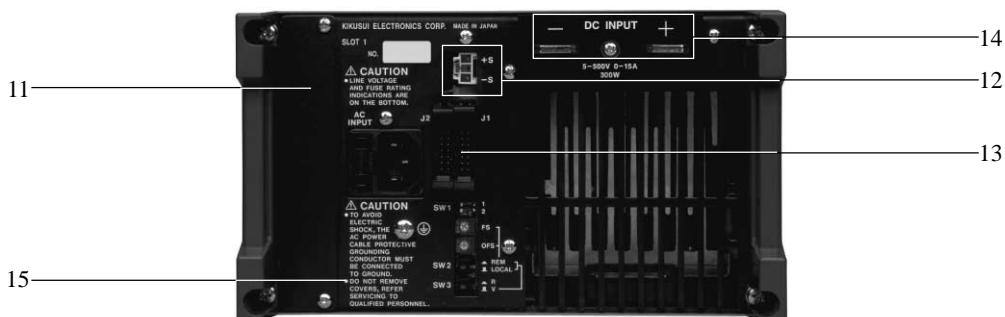

# PLZ-3W/3WH series

## ELECTRONIC LOAD (CC·CR·CV·CP)

### Designed to Meet Today's More Complex Loading Conditions

● **Constant power mode useful for battery discharge tests**  
Loads of constant power such as DC/DC converters are being used increasingly for batteries, and evaluation tests on such loads also require the use of constant power. Since the PLZ-3W/3WH Series have a C.P mode, you can conduct these types of load tests (such as constant-power discharge tests) under highly realistic conditions.

● **Setting of various conditions Variable rise/fall time function**  
When the set current needs to change abruptly, a rise/fall time (Tr/Tf) to reach the set value can be selected using one of eight values between 50  $\mu$ s and 10 ms. This allows the instruments to set up various conditions for tests in order to support tests such as transitional response tests of power supplies. The instruments can also produce accurate simulation waveforms using the sequence function. If the device being tested has an L component, setting Tr/Tf to a slower interval will prevent overvoltages caused by the L component. (Note: available Tr/Tf time settings = 50  $\mu$ s, 100  $\mu$ s, 200  $\mu$ s, 500  $\mu$ s, 1 ms, 2 ms, 5 ms, and 10 ms)

● **Sequence function that allows complicated current simulations**  
Because instruments in the PLZ-3W/3WH Series have a sequence function that sequentially processes the data stored in each step memory, a variety of current simulations may be performed. Sequence data can be input either from the front panel or through an external controller using an optional interface. Input data may also be stored in an optional memory card. The sequence function offers two modes: a fast-speed mode that enables programming of 100  $\mu$ s high-speed steps, and a normal-speed mode that allows programming of ramp waveforms in a single step.

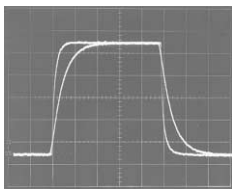

Rise/fall time(in C.C mode)  
H: 0.2 ms/div,V: 12A/div  
Rising and falling waveforms of  
50  $\mu$ s and 200 $\mu$ s

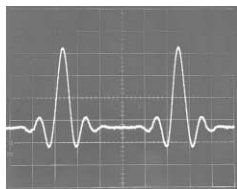

Sequence mode (in C.C mode  
and fast-speed mode)  
H: 5 ms/div,V: 10 A/div

● **Sequence function**

■ **Normal Speed**

Settable items	I SET value (constant current), R SET value (constant resistance), P SET value(constant power), V SET value(constant voltage) Trigger output Load on/off Setting of short-circuit function Specification of step transition or ramp transition
Step execution time	Time can be set for each step. However,the range is fixed for each sequence. (1)1 to 9999 ms (2)1 to 999.9 s (3)1 s to 999 min and 59 s (4)1 min to 999 hr and 59 min
Pause	Provided
Maximum number of steps	256
Number of repetitions	1 to 9998 and $\infty$
Number of programs	16
Number of sequences to be stored in a memory card	8
Number of sequences	32 Maximum

■ **Fast speed**

Settable items	I SET value (constant current), R SET value (constant resistance), Trigger output
Step execution time	Step time can be set on a program basis. (1)0.1 ms to 100 ms
Pause	Not provided
Maximum number of steps	1024
Number of repetitions	1 to 9998 and $\infty$
Number of programs	16
Number of sequences to be stored in a memory card	8
Number of sequences	32 Maximum

### To Support Today's More Diverse Experiments and Tests

● **Setup function and backup memories**  
Different set values can be stored as part of a setup routine in the built-in backup memories and in the optional memory card, where they can be easily accessed. These backup memories can store a maximum of four setups and the memory card, 50 setups.

● **Remote sensing that compensates precisely for set values**  
Remote sensing will compensate for voltage drops in load lines, allowing resistance, voltage, and power values to be set precisely. This

especially improves the transitional characteristics in the C.R and C.P modes.

● **Trigger signal output useful for waveform monitoring**  
The instruments will output trigger signals when trigger output is specified either in sequence operation or during switching operation. These signals can then be used as synchronous signals for external instruments such as oscilloscopes, providing an easy means of waveform observation.

# PLZ-3W/3WH series

## ELECTRONIC LOAD (CC-CR-CV-CP)

### To Support Today's More Diverse Experiments and Tests

#### ● Three-memory function and switching function

Individual set values can be stored in three memories [A], [B], and [C] and can be recalled freely. For the C.C and C.R modes, the instruments have a switching function that recalls these values from the memories in the order [A], [B], [C], [A], [B], [C], .... and executes them repeatedly.

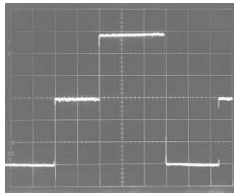

Switching waveform  
(in C.C mode)  
H: 5 ms/div, V: 10A/div  
Memory A 0 A, 12 ms  
Memory B 30 A, 10 ms  
Memory C 59 A, 15 ms

#### ● Soft-start function that suppresses output voltage distortion

The start-up time of the instruments can be changed in accordance with the output-voltage rise time for the device being tested. This allows them to conduct tests which more closely approximate real-world conditions.

(Soft-start time: Selectable from 0.1, 1, 2, 5, 10, 20, 50, and 100 ms)

Note: In case of PLZ-3WH series, selectable from 0.5ms.

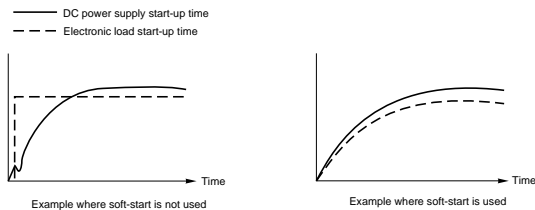

Example where soft-start is not used

Example where soft-start is used

#### ● Short-circuit function that allows instantaneous setting of the maximum current

During operations in C.C or C.R mode, pressing the SHORT key allows you to set either the maximum current value (in C.C mode) or minimum resistance value (in C.R mode) of the range instantaneously, without using the JOG or SHUTTLE key. In addition, when a large-current relay or other element is connected to the external control connector as shown below, if the voltage at the load terminals falls below approximately 1.5 V, the load terminals will be in a short-circuit state. This allows the instruments to perform effectively at currents of 1.5 V or less during current-limiting drooping characteristic tests of DC power supplies.

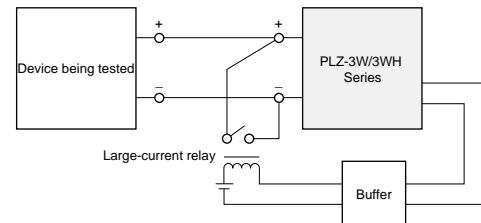

### To Meet More Expanding Applications

#### ● Memory card that allows significantly improved operability

Data set from the front panel or through GPIB can be saved in the optional memory card. Using this card, other sections such as production and inspection lines can easily recall setup data and set up current simulation data.



Memory card (SMC-32)

#### ● Parallel operations that offer increased current and power capacities

The PLZ-3W/3WH Series allow parallel connection of identical models in order to increase current and power capacities. In parallel operations, a single master unit can control multiple slaves, such as setting total current for all. Naturally, the total current is also displayed on the monitors. A maximum of five instruments can be operated in parallel.

Model	Rated capacities in parallel operations			
	For 2 units	For 3 units	For 4 units	For 5 units
PLZ153W	300W,60A	450W,90A	600W,120A	750W,150A
PLZ303W	600W,120A	900W,180A	1200W,240A	1500W,300A
PLZ603W	1200W,240A	1800W,360A	2400W,480A	3000W,600A
PLZ1003W	2000W,400A	3000W,600A	4000W,800A	5000W,1000A
PLZ153WH	300W,15A	450W,22.5A	600W,30A	750W,37.5A
PLZ303WH	600W,30A	900W,45A	1200W,60A	1500W,75A
PLZ603WH	1200W,60A	1800W,90A	2400W,120A	3000W,150A
PLZ1003WH	2000W,100A	3000W,150A	4000W,200A	5000W,250A

\* Please order parallel operation cable (model PC01-PLZ-3W) when connecting the PLZ-3W/3WH Series in parallel.

# PLZ-3W/3WH series

## ELECTRONIC LOAD (CC·CR·CV·CP)

### Interfaces

When an optional interface is used, the PLZ-3W/3WH Series allow the PLZ-3W/3WH front panel to be fully controlled through an external controller. Since the external controller can also read back DC input voltage, DC input current, and DC input power values in addition to set values, you can use this capability to configure various systems. Suitable interfaces include the IB11 GPIB and RS11 RS-232C interfaces, both of which include the Kikusui-designed multi-channel bus (MCB) feature. This allows a maximum of 16 units to be controlled for a single address of the GPIB interface or a single port of the RS-232C interface. (Note: The slot for an optional board allows an IB11, RS11, or MC11S to be connected.)



Interface slot



A variety of optional interfaces

#### ● MCB system (Example 1)

The use of the MCB allows easy configuration of various large systems when you wish to test a large number of devices together, conduct load tests of multi-output switching power supplies, or attempt related applications.

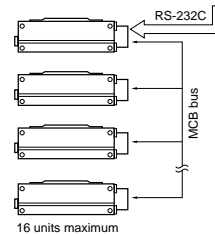

#### ● MCB system (Example 2)

The MCB can also be used for the PAX Series high-speed programmable DC power supplies and PBX Series high-speed bipolar power supplies. Thus, for example, use of a RS-232C allows a single notebook PC to configure a DC/DC converter test system using either the PAX or PBX Series, as shown below.

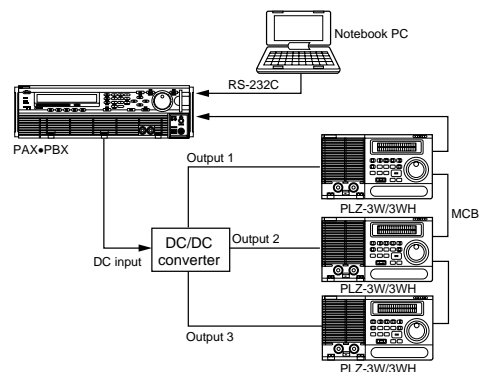

### Remote Control

By connecting a remote controller RC02-PLZ or 10-key pad RC11 to the PLZ-3W/3WH Series, you can directly input values for current (I SET), resistance (R SET), and power (P SET) or time settings. In particular, the RC02-PLZ allows the PLZ-3W/3WH front panel to be controlled in hand.

#### ● Remote controller RC02-PLZ



Control items:

- Same setting features as on front panels of instruments
- Direct setting (numeric input) of I SET, R SET, V SET and P SET values
- Direct setting (numeric input) of above SET values and time in the memories A, B, and C
- Direct setting (numeric input) of I SET, R SET, V SET, and P SET values and time in the sequence mode

#### ● 10-key pad RC11



Control items:

- Direct setting (numeric input) of I SET, R SET, V SET, and P SET values
- Direct setting (numeric input) of the above SET values and time in the memories A, B, and C
- Direct setting (numeric input) of I SET, R SET, V SET, and P SET values and time in the sequence mode
- Load on/off

# PLZ-3W/3WH series

## ELECTRONIC LOAD (CC-CR-CV-CP)

### Applications

#### ● Actual-load simulations

The sequence function is used to capture real waveform data into the memory card. This allows actual-load simulations to be conducted.

#### Capturing Data:

The load current of a motor is captured using an oscilloscope, and the waveform data is saved in the memory card of the PLZ-3W/3WH through the GPIB interface.

#### Calling the data:

As the data stored in the memory card is available even when the GPIB interface is disconnected, you can do actual-load simulations in test lines or without integrating a complicated system.

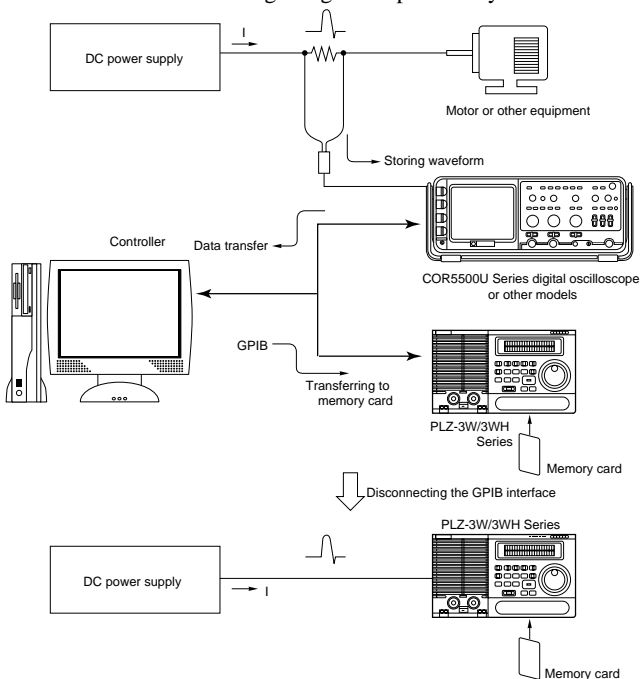

#### ● Automatic test system for DC current

Combining the PLZ-3W/3WH Series with a Kikusui PCR-L Series AC power supply allows you to configure an automatic test system for switching power supplies.

#### AC input side test ... PCR-L Series:

- Power line abnormality simulations
- AC line regulation tests
- Instantaneous power failure tests and others

#### DC loading test ... PLZ-3W/3WH Series:

- Loading simulations
- Load regulation tests
- Transitional response tests
- Current-limiting characteristic tests and others

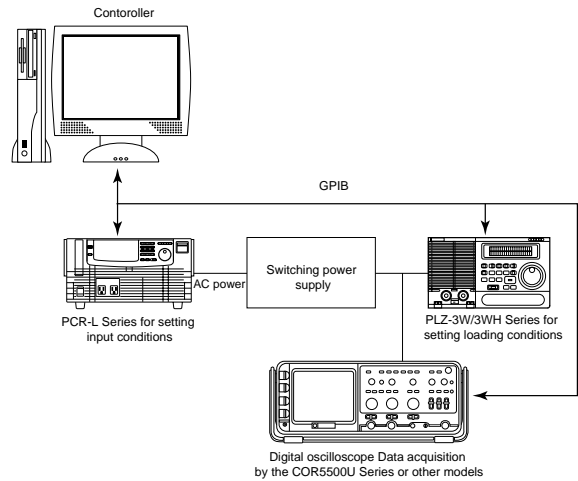

# PLZ-3W/3WH series

## ELECTRONIC LOAD (CC·CR·CV·CP)

### Specifications(PLZ-3WH series)

#### ■ Operating Area

	PLZ153WH	PLZ303WH	PLZ603WH	PLZ1003WH
Operating voltage (DC)*1	5 to 500 V			
Current	7.5 A	15 A	30 A	50 A
Power	150 W	300 W	600 W	1000 W
Minimum operation-starting voltage*2	1 V			

\*1 Current can flow in a range of 1 to 5 V. However, the specifications for this instrument may not be met.

\*2 Minimum voltage at which current starts to flow in the instrument

#### ■ Constant Current Mode

	PLZ153WH	PLZ303WH	PLZ603WH	PLZ1003WH
Operating range				
Range H	0 to 7.5 A	0 to 15 A	0 to 30 A	0 to 50 A
Range L	0 to 0.75 A	0 to 1.5 A	0 to 3 A	0 to 5 A
Setting accuracy (with respect to rated current)*1	±(0.3% + 7.5 mA)	±(0.3% + 15 mA)	±(0.3% + 30 mA)	±(0.3% + 50 mA)
Setting resolution				
Range H	2 mA	4 mA	8 mA	13 mA
Range L	0.2 mA	0.4 mA	0.8 mA	1.3 mA
Stability				
Line regulation*2	3 mA			
DC input voltage regulation*3	20 mA			
Temperature coefficient	±100 ppm/°C of rated current (typical value)			
Ripple noise*4				
RMS*5	2 mA	2 mA	3 mA	5 mA
Measuring current*6	At 7.5 A	At 15 A	At 30 A	At 50 A
Peak-to-peak	20 mA	20 mA	30 mA	50 mA
Measuring current	At 7.5 A	At 15 A	At 30 A	At 50 A

\*1 In a range of 23±5°C

\*2 With respect to a variation of ±10% of the center value of the input supply voltage at the rated current of 20 V input voltage

\*3 Value obtained when input voltage is varied from 5 V to 500 V at the current of rated power/500 V

\*4 At the rated current of 20 V input voltage

\*5 5 Hz to 500 kHz

\*6 DC to 15 MHz

#### ■ Constant Resistance Mode

	PLZ153WH	PLZ303WH	PLZ603WH	PLZ1003WH
Operating range				
Range H*5	1.6Ω to 20kΩ 0.625 to 1.25 to 5×10 <sup>-5</sup> S	0.8Ω to 10kΩ 1.25 to 1×10 <sup>-4</sup> S	0.4Ω to 5kΩ 2.5 to 2×10 <sup>-4</sup> S	0.24Ω to 3kΩ 4.17 to 3.3×10 <sup>-4</sup> S
Range L*5	16Ω to 200kΩ 0.0625 to 5×10 <sup>-6</sup> S	8Ω to 100kΩ 0.125 to 1×10 <sup>-5</sup> S	4Ω to 50kΩ 0.25 to 2×10 <sup>-5</sup> S	2.4Ω to 30kΩ 0.417 to 3.3×10 <sup>-5</sup> S
Setting resolution				
Range H*6	0.156 mS	0.3125 mS	0.625 mS	1 mS
Range L*6	0.0156 mS	0.03125 mS	0.0625 mS	0.1 mS
Setting accuracy (current conversion)*1	±(1% of rated current + a)*3			
Stability				
DC input voltage regulation*2	6%			
Temperature coefficient	±(1000 ppm/°C + 4 mΩ/°C) at minimum resistance value			
Ripple noise*4	Complies with graph 1 (typical values)			

\*1 In a range of 23±5°C and at 12 V input voltage

\*2 With respect to an input voltage change of 5 V to 12 V at the minimum resistance value. For other resistance, the voltage variations will be within 6% of the maximum conductance (S) value of the setting range with respect to variations in all input voltages. (with the load terminals remote sensed)

\*3  $a = 12 V \div \text{set resistance} - 12 V \div (\text{set resistance} + 120 m\Omega)$

\*4 A repetitive noise of about 155 kHz may be superimposed on input current.

\*5 S:siemens

\*6 mS: millisiemens

Note: Conductance (S) x input voltage (V) = load current (A)

Conductance (S) = 1/resistance (Ω)

#### ■ Constant Voltage Mode

	PLZ153WH	PLZ303WH	PLZ603WH	PLZ1003WH
Operating range (DC)	5 V to 500 V			
Setting accuracy*1	±0.1% of rated voltage			
Setting resolution	125 mV			
DC input current regulation*2	±0.01% of rated voltage			
Temperature coefficient	±100 ppm/°C of rated voltage (typical value)			

\*1 In a range of 23±5°C (with the load terminals remote sensed)

\*2 With respect to an input current change of 10% to 100% of the rated current at 5 V input voltage (with the load terminals remote sensed)

#### ■ Constant Power Mode

	PLZ153WH	PLZ303WH	PLZ603WH	PLZ1003WH
Operating range	15 to 150 W	30 to 300 W	60 to 600 W	100 to 1000 W
Setting accuracy*1	±2% of rated power			
Setting resolution	0.025% of rated power			
DC input voltage regulation*2	2% of rated power			
Ripple current*3	Complies with graph 2 (typical values)			
Temperature coefficient	±1000 ppm/°C of rated power (typical value)			

\*1 In a range of 23±5°C and at 20 V input voltage (with the load terminals remote sensed)

\*2 With respect to an input voltage change of 20 V to 500 V at rated power (with the load terminals remote sensed)

\*3 When the ripple noise of input voltage is 5 mV or less

#### ■ Tr/Tf, Switching and Soft-start Operations, Remote Sensing, and Protective Features

	PLZ153WH	PLZ303WH	PLZ603WH	PLZ1003WH
Tr/Tf setting*1				
Operation mode	Constant current			
Setting range	50, 100, 200, 500 μs 1, 2, 5, 10 ms			
Setting accuracy*2	±30% of set value, ±15 μs			
Switching operation				
Operation mode	Constant current, constant resistance			
Time setting range	1 to 5000 ms			
Time setting accuracy	±5% of set value			
Soft-start operation				
Operation mode	Constant current(C.C)			
Setting range	0.5, 1, 2, 5, 10, 20, 50, 100 ms			
Setting accuracy	±30% of set value, ±100 μs			
Remote sensing				
Sensing voltage	5 V*3			
Protective features				
Over current protection (OCP)	Limit is activated at about +5% of rated current.			
Overheat protection (OHP)	Load current is cut off at a heat at sink temperature of about 105°C.			
Reverse connection protection	With diodes and fuses			
Power transistor protection	With fuses			
Overvoltage protection (OVP)	Load switch will be turned off.			

\*1 Within an input voltage range of 12 V to 500 V.

Rise time (Tr) and fall time (Tf) are times required to reach 10% to 90% of current waveform.

\*2 Tr/Tf setting is valid when the changes in load current fall within a range of 2% to 100% of the rated current value.

\*3 2.5 V at one terminal

# PLZ-3W/3WH series

## ELECTRONIC LOAD (CC·CR·CV·CP)

### External Control Connector

	PLZ153WH	PLZ303WH	PLZ603WH	PLZ1003WH
I/O slot	One of IB11, RS11, and MC11S can be connected.			
Voltage control terminals for C.C/C.R *1	0 A when voltage is 0 V, and rated current when 10 V (in C.C mode) Maximum resistance when voltage is 0 V, and minimum resistance when 10 V (in C.R mode)			
Resistance control terminals for C.C/C.R	Rated current when resistance is about 0 Ω, and 0 A when about 10 kΩ (in C.C mode) Minimum resistance when resistance is about 0 Ω, and maximum resistance when about 10 kΩ (in C.R mode)			
Voltage control terminals for C.P	Rated power when voltage is about 10 V			
Load-on/off monitoring output terminals (floating output)	Photo coupler (open collector) Rated voltage: 30 V Rated current: 5 mA			
Load-on/off signal input terminal	Comparator level: about 7 V 3.3 kΩ is pulled up at 15 V.			
Range selector signal input terminals	CMOS level 10 kΩ is pulled up at 5 V.			
Trigger signal output terminals (floating output)				
Output resistance	10 kΩ			
Output voltage	3.5 V			
Pulse width	Approx. 10 μs			
Trigger input terminals	CMOS level Pull down at 100 kΩ.			
Current monitoring terminals (output of a sum of currents)	Rated current/1 V			
Short-circuit signal output	Relay contact output (25 V DC, 0.5 A)			

\*1 In full scale, and offset adjustable

### Others

	PLZ153WH	PLZ303WH	PLZ603WH	PLZ1003WH										
Input power supply (AC)														
Input supply voltage range AC	<table border="1"> <thead> <tr> <th>Range</th> <th>Center voltage</th> </tr> </thead> <tbody> <tr> <td>[1] 90 to110</td> <td>100</td> </tr> <tr> <td>[2] 108 to132</td> <td>120</td> </tr> <tr> <td>[3] 180 to220</td> <td>200</td> </tr> <tr> <td>[4] 216 to250</td> <td>240</td> </tr> </tbody> </table> [1], [2], [3], or [4] is selectable.				Range	Center voltage	[1] 90 to110	100	[2] 108 to132	120	[3] 180 to220	200	[4] 216 to250	240
Range	Center voltage													
[1] 90 to110	100													
[2] 108 to132	120													
[3] 180 to220	200													
[4] 216 to250	240													
Frequency	50/60 Hz AC													
Power consumption (VA) (When the GPIB board is connected)	Approx. 50 (60)	Approx. 50 (60)	Approx. 65 (75)	Approx. 80 (90)										
Rush current (A)	Approx. 18	Approx. 22	Approx. 28	Approx. 32										
Withstand voltage														
Primary circuit to load terminals	1500 V AC for 1 min													
Primary circuit to chassis	1500 V AC for 1 min													
Load terminals to chassis	500 V DC for 1 min													
Insulation resistance														
Primary circuit to load terminals	1000 V DC, 30 MΩ or more													
Primary circuit to chassis	1000 V DC, 30 MΩ or more													
Load terminals to chassis	1000 V DC, 20 MΩ or more													
Operating temperature range	0 to 40°C													
Operating humidity range	30 to 80% RH (no condensation)													
Storage temperature range	-20 to 70°C													
Storage humidity range	30 to 80% RH (no condensation)													
Weight (kg)	Approx. 8.5	Approx. 10	Approx. 16	Approx. 19.5										

### Indicators

	PLZ153WH	PLZ303WH	PLZ603WH	PLZ1003WH
Ammeter				
Display digits	7.500A	15.00A	30.00A	50.00A
Accuracy*1	±(0.25% of FS + 2 digits)		±(0.25% of FS + 1 digit)	
Temperature coefficient	±100 ppm/°C of FS (typical value)			
Voltmeter				
Display digits	500.0V			
Accuracy*1	±(0.2% of FS + 2 digits)			
Temperature coefficient	±100 ppm/°C of FS (typical value)			
Power meter				
Display digits	_ 150.0W _ _ 300.0W _ _ 600.0W _ _ 1000W _ Displays the results of multiplying current value and voltage value. ±8% of FS			

\*1 In a range of 23±5°C

### Sub-front panel

	PLZ153WH	PLZ303WH	PLZ603WH	PLZ1003WH
Current monitoring terminals	1 V output at rated current			
Remote control connector	8-pin mini-connector (RC11 or RC02-PLZ is connectable.)			
Trigger signal output terminals				
Output resistance	10 kΩ			
Output voltage	3.5 V			
Pulse width	Approx. 10 μs			

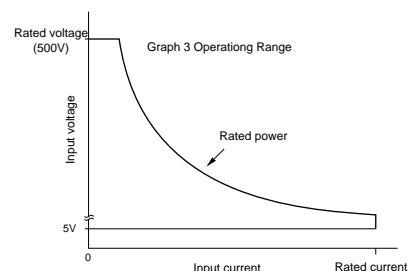
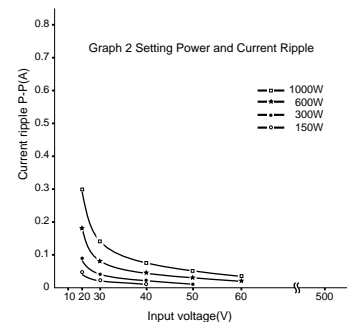
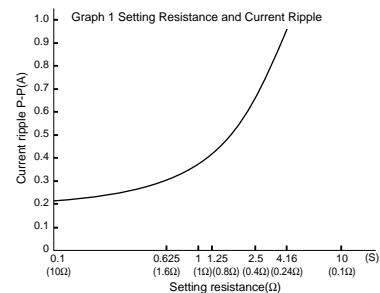



# PLZ-3W/3WH series

## ELECTRONIC LOAD (CC·CR·CV·CP)

### Specifications(PLZ-3W series)

#### ■ Operating Area

	PLZ153W	PLZ303W	PLZ603W	PLZ1003W
Operating voltage (DC)	1.5 to 120 V			
Current	30 A	60 A	120 A	200 A
Power	150 W	300 W	600 W	1000 W
Minimum operation-starting voltage*1	0.3 V			

\*1 Current can flow in a range of 0.3 to 1.5 V. However, the specifications for this instrument may not be met.

#### ■ Constant Current Mode

	PLZ153W	PLZ303W	PLZ603W	PLZ1003W
Operating range				
Range H	0 to 30A	0 to 60A	0 to 120 A	0 to 200 A
Range L	0 to 3 A	0 to 6 A	0 to 12 A	0 to 20 A
Setting accuracy (with respect to rated current)*1	±(0.3% + 30 mA)	±(0.3% + 60 mA)	±(0.3% + 120 mA)	±(0.3% + 200 mA)
Setting resolution				
Range H	8 mA	15 mA	30 mA	60 mA
Range L	0.8 mA	1.5 mA	3 mA	6 mA
Stability				
Line regulation*2	3 mA			
DC input voltage regulation*3	10 mA			
Temperature coefficient	±100 ppm/°C of rated current (typical value)			
Ripple noise*4				
RMS*5	3 mA	5 mA	10 mA	20 mA
Measuring current*6	At 30 A	At 60 A	At 100 A	At 100 A
Peak-to-peak	30 mA	30 mA	50 mA	100 mA
Measuring current	At 30 A	At 60 A	At 100 A	At 100 A

\*1 In a range of 23±5°C

\*2 With respect to a variation of ±10% of the center value of input supply voltage at the rated current of 5 V input voltage

\*3 Value obtained when input voltage is varied from 1.5 V to 120 V at the current of rated power/120 V

\*4 At the rated current of 1.5 V input voltage

\*5 5 Hz to 500 kHz

\*6 DC to 15 MHz

#### ■ Constant Resistance Mode

	PLZ153W	PLZ303W	PLZ603W	PLZ1003W
Operating range				
Range H*4	0.1 to 10 Ω	0.05 to 5 Ω	0.025 to 2.5 Ω	0.015 to 1 Ω
	10 to 0.1 S	20 to 0.2 S	40 to 0.4 S	66 to 1 S
Range L*4	1 to 100 Ω	0.5 to 50 Ω	0.25 to 25 Ω	0.15 to 10 Ω
	1 to 0.01 S	2 to 0.02 S	4 to 0.04 S	6.6 to 0.1 S
Setting resolution				
Range H*5	0.25 mS	0.5 mS	1 mS	2.5 mS
Range L*5	0.025 mS	0.05 mS	0.1 mS	0.25 mS
Setting accuracy (current conversion)*1	±(1% of rated current + α)*3			
Stability				
DC input voltage regulation*2	6%			
Temperature coefficient	±(1000 ppm/°C + 1 mΩ/°C) at minimum resistance value			
Ripple noise	Complies with graph 1 (typical values)			

\*1 In a range of 23±5°C and at 3 V input voltage

\*2 With respect to an input voltage change of 1.5 V to 3.0 V at the minimum resistance value. For other resistance, the voltage variations will be within 6% of the maximum conductance (S) value of the setting range with respect to variations in all input voltages. (These values were obtained with the load terminals remote sensed.)

\*3  $\alpha = 3 \text{ V} \div \text{set resistance} - 3 \text{ V} \div (\text{set resistance} + 8 \text{ m}\Omega)$

\*4 S: siemens

\*5 mS: millisiemens

Note: Conductance (S) x input voltage (V) = load current (A)

Conductance (S) = 1/resistance (Ω)

#### ■ Constant Voltage Mode

	PLZ153W	PLZ303W	PLZ603W	PLZ1003W
Operating range (DC)	1.5 V to 120 V			
Setting accuracy*1	±0.1% of rated voltage			
Setting resolution	30 mV			
DC input current regulation*2	±0.01% of rated voltage			
Temperature coefficient	±100 ppm/°C of rated voltage (typical value)			

\*1 In a range of 23±5°C (with load terminal remote sensing)

\*2 With respect to a change in the input current of 10% to 100% of the rated current at 1.5 V input voltage (with load terminal remote sensing)

#### ■ Constant Power Mode

	PLZ153W	PLZ303W	PLZ603W	PLZ1003W
Operating range (DC)	15 to 150 W	30 to 300 W	60 to 600 W	100 to 1000 W
Setting accuracy*1	±2% of rated power			
Setting resolution	0.025% of rated power			
DC input voltage regulation*2	2% of rated power			
Ripple current*3	Complies with graph 2 (typical values)			
Temperature coefficient	±1000 ppm/°C of rated power (typical value)			

\*1 In a range of 23±5°C and at 5 V input voltage (with load terminal remote sensing)

\*2 With respect to an input voltage change of 6 V to 120 V at rated power (with load terminal remote sensing)

\*3 When the ripple noise of input voltage is 5 mV or less

#### ■ Tr/Tf, Switching and Soft-start Operations, Remote Sensing, and Protective Features

	PLZ153W	PLZ303W	PLZ603W	PLZ1003W
Tr/Tf setting*1				
Operation mode	Constant current			
Setting range	50, 100, 200, 500 μs 1, 2, 5, 10 ms			
Setting accuracy*2	±30% of set value, ±15 μs			
Switching operation				
Operation mode	Constant current, constant resistance			
Time setting range	1 to 5000 ms			
Time setting accuracy	±5% of set value			
Soft-start operation				
Operation mode	Constant current(C.C)			
Setting range	0.1, 1, 2, 5, 10, 20, 50, 100 ms			
Setting accuracy	±30% of set value, ±100 μs			
Remote sensing				
Sensing voltage	5 V*3			
Protective features				
Over current protection (OCP)	Limit is activated at about +5% of rated current.			
Overheat protection (OHP)	Load current is cut off at a heat sink temperature of about 105°C.			
Reverse connection protection	With diodes and fuses			
Power transistor protection	With fuses			
Overvoltage protection (OVP)	Load switch will be turned off.			

\*1 In an input voltage range of 3 V to 120 V.

Rise time (Tr) and fall time (Tf) are times required to reach 10% to 90% of current waveform.

\*2 Tr/Tf setting is valid when the range of changes in load current is 2% to 100% of the rated current value.

\*3 2.5 V at one terminal

# PLZ-3W/3WH series

## ELECTRONIC LOAD (CC·CR·CV·CP)

### ■ Indicators

	PLZ153W	PLZ303W	PLZ603W	PLZ1003W
<b>Ammeter</b>				
Display digits	30.00A	60.00A	99.99A 120.0A*2	99.99A 200.0A*2
Accuracy*1	±(0.25% of FS + 1 digit)		±(0.25% of FS + 3 digits)	
Temperature coefficient	±100 ppm/°C of FS (typical value)			
<b>Voltmeter</b>				
Display digits	99.99V 120.0V*3			
Accuracy*1	±(0.2% of FS + 1 digit)			
Temperature coefficient	±100 ppm/°C of FS (typical value)			
<b>Power meter</b>				
Display digits	_ 150.0W _ _ 300.0W _ _ 600W _ _ 1000W _ Displays the results of multiplying current value and voltage value.			

\*1 In a range of 23±5°C

\*2 For 100 A or more, up to one digit below the decimal point will be indicated.

\*3 For 100 V or more, up to one digit below the decimal point will be indicated.

### ■ Sub-front panel

	PLZ153W	PLZ303W	PLZ603W	PLZ1003W
Current monitoring terminals	1 V output at rated current			
Remote control connector	8-pin mini-connector (RC11 or RC02-PLZ is connectable.)			
<b>Trigger signal output terminals</b>				
Output resistance	10 kΩ			
Output voltage	3.5 V			
Pulse width	Approx. 10 μs			

### ■ External Control Connector

	PLZ153W	PLZ303W	PLZ603W	PLZ1003W
C.C/C.R voltage control terminals*1	0 A when voltage is 0 V, and rated current when 10 V (in C.C mode) Maximum resistance when voltage is 0 V, and minimum resistance when 10 V (in C.R mode)			
C.C/C.R resistance control terminals	Rated current when resistance is about 0 Ω, and 0 A when about 10 kΩ (in C.C mode) Minimum resistance when resistance is about 0 Ω, and maximum resistance when about 10 kΩ (in C.R mode)			
C.P voltage control terminals	Rated power when voltage is about 10 V			
Load-on/off monitoring output terminals (floating output)	Photo coupler (open collector) Rated voltage: 30 V Rated current: 5 mA			
Load-on/off signal input terminal	Comparator level: about 7 V 3.3 kΩ is pulled up with 15 V.			
Range selector signal input terminals	CMOS level 10 kΩ is pulled up with 5 V.			
<b>Trigger signal output terminals (floating output)</b>				
Output resistance	10 kΩ			
Output voltage	3.5 V			
Pulse width	Approx. 10 μs			
Trigger input terminals	CMOS level Pull down at 100 kΩ			
Current monitoring terminals (output of a sum of currents)	Rated current/1 V			
Short-circuit signal output	Relay contact output (25 V DC, 0.5 A)			

\*1 In full scale, and offset adjustable

### ■ Others

	PLZ153W	PLZ303W	PLZ603W	PLZ1003W
<b>Input power supply (AC)</b>				
Input supply voltage range (AC)	Range		Center voltage	
	[1]	90 to110	100	
	[2]	108 to132	120	
	[3]	180 to220	200	
	[4]	216 to250	240	
	[1], [2], [3], or [4] is selectable.			
Frequency	50/60 Hz AC			
Power consumption (VA) (When the GPIB board is connected)	Approx. 50 (60)	Approx. 55 (65)	Approx. 70 (80)	Approx. 110 (120)
Rush current (A)	Approx. 18	Approx. 22	Approx. 28	Approx. 32
<b>Withstand voltage</b>				
Primary circuit to load terminals	1500 V AC for 1 min			
Primary circuit to chassis	1500 V AC for 1 min			
<b>Insulation resistance</b>				
Primary circuit to load terminals	500 V DC, 30 MΩ or more			
Primary circuit to chassis	500 V DC, 30 MΩ or more			
Load terminals to chassis	500 V DC, 20 MΩ or more			
Operating temperature range	0 to 40°C			
Operating humidity range	30 to 80% RH (no condensation)			
Storage temperature range	-20 to 70°C			
Storage humidity range	30 to 80% RH (no condensation)			
Weight (kg)	Approx. 8.5	Approx. 10	Approx. 16	Approx. 19.5

