



S8000 Remote High Precision Chilled Mirror Hygrometer

A hygrometer offering a combination of market-leading $\pm 0.1^\circ\text{C}$ accuracy with the flexibility of a remote sensor, allowing for straightforward installation and precision monitoring of environmental moisture. This highly sensitive, adaptable instrument can provide extremely accurate measurements in situ in the area of interest, or in an industrial process.



Highlights

- Fundamental, accurate and drift-free measurement
- Remote sensor
- Open design allows remote sensor to be mounted into a sample flow or simply placed in an environment to be monitored
- -40 to $+120^\circ\text{C}$ dew-point range with $\pm 0.1^\circ\text{C}$ accuracy
- Data logging via USB, Ethernet and SD card
- 'FAST' guarantees frost formation below 0°C
- Sensor operates in pressures up to 20 barg

Applications

- Engine test cell monitoring – from commercial vehicle to high performance engines
- Environmental chamber verification for:
 - Component testing
 - Corrosion testing
 - Pharmaceutical validation
- Precision HVAC control
- Lithium Ion battery manufacture



S8000 Remote Precision Optical Dew-point Hygrometer

Setting the Standard

The S8000 Remote chilled-mirror sensor directly measures the formation of condensation, giving long-term, drift-free readings of dew-point and relative humidity. It offers a wide measurement range from the equivalent of <math><0.5</math> to 100% RH (dew point range:

Precision Measurements

The S8000 Remote features a new sensor design, incorporating a high precision 1/10DIN PT100 to provide $\pm 0.1^{\circ}\text{C}</math> accuracy of dew-point measurement. Combined with the $\pm 0.1^{\circ}\text{C}</math> accuracy temperature measurement sensor, the RH measurement accuracy of the S8000 Remote is better than other products currently available on the market.$$

To further improve the accuracy of pressure-derived calculated values an optional external pressure transducer can be supplied, which provides real-time pressure compensation for these parameters. This allows for continued measurement stability even during sample pressure fluctuations.

Use Your Preferred Communication Media

The S8000 Remote can be ordered with a wide range of communication protocols:

- Modbus RTU over:
 - USB
 - RS232
 - RS485
- Modbus TCP over Ethernet
- 3 user configurable 0/4–20mA
- Status and Process Alarm contacts
- Datalogging to SD Card

The choice of communication methods allows straightforward connection to a DCS, PLC or datalogger. Alternatively, Michell provides specific PC-based application software for the S8000 Remote, allowing control of all instrument functionality remotely, and the ability to graph and log any measured or calculated parameters directly to the host PC, either via direct connection or across a network.

High Contrast Display with Built-in Data Logging

A high-contrast touch screen LCD display provides entirely customizable local indication of the measured values, along with a trend graph and fault warnings.

A sophisticated built-in logging system provides the facility to log the values of all the instrument parameters at operator specified intervals. The log files are saved directly onto a removable SD memory card (supplied), allowing the logs to be easily transferred to a PC for analysis or correlation with test results.

Flexibility of Use & Simplicity of Installation

The remote sensor design eliminates the potential problems usually associated with building sampling systems. The open cell sensor can now be placed directly into the environment to be monitored and does not always need a complex and expensive sampling arrangement or pump to convey the gas to be measured to the instrument.

For more challenging applications, where direct insertion is not possible, the sensor can be mounted in a sample block and included in a sampling system. This means that the product can be used for a wide range of applications, and with trace heating - including those up to dew-point temperatures of



Application: Climatic chamber monitoring

Technology: Chilled Mirror

Michell's chilled mirror hygrometers are precision instruments for critical measurement and control applications. Chilled mirror sensors measure a primary characteristic of moisture – the temperature at which condensation forms on a surface.

This means that chilled mirror instruments:

- Have no drift: the temperature at which condensation forms is measured directly so there are no calculated variables that could shift over time
- Are inherently repeatable, giving reliable results every time

The chilled mirror sensor consists of a temperature controlled mirror and an advanced optical detection system.

A beam of light from an LED **(1)** is focused on the mirror surface **(2)** with a fixed intensity.

As the mirror is cooled, less light is reflected due to the scattering effect of the condensate formed on the mirror surface. The level of reflected light is measured by a photo-detector **(3)**.

The signals from this optics system are used to precisely control the drive to a solid state thermoelectric cooler (TEC) **(4)**, which heats or cools the mirror surface. The mirror surface is then controlled in an equilibrium state whereby evaporation and condensation are occurring at the same rate. In this condition, the temperature of the mirror, measured by a platinum resistance thermometer **(5)**, is equal to the dew-point temperature of the gas.

Our chilled mirror instruments prove their reliability on a daily basis in our production processes and service centres, as well as in our UKAS-accredited calibration laboratory.

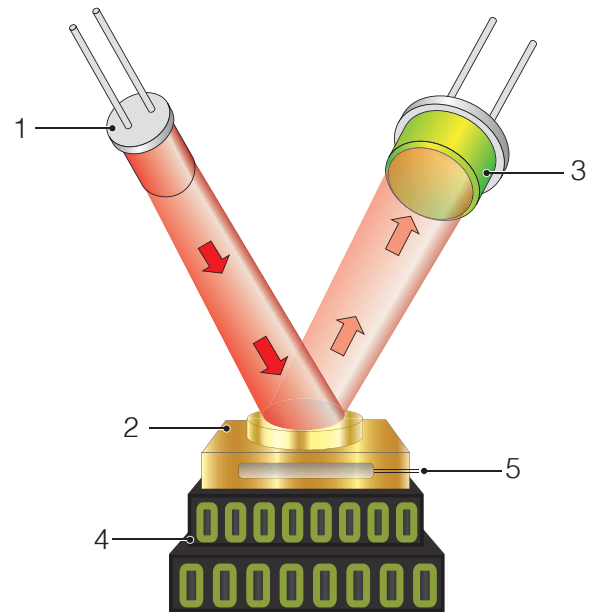

Technical Specifications

Dew-Point Sensor Performance			
Accuracy	±0.1°C (±0.18°F)		
Reproducibility	±0.05°C (±0.09°F)		
Measurement technology	Chilled Mirror		
Sensor	2-Stage	High Temp PEEK	Climatic head
Dew-point range	-40°Cdp @ sensor temp of +20°C +90°Cdp @ sensor temp of +90°C	-40°Cdp @ sensor temp of +20°C +120°Cdp @ sensor temp of +120°C	-10°Cdp @ sensor temp of +20°C +120°Cdp @ sensor temp of +120°C
Temperature range	-40 to +90°C	-40 to +120°C	-40 to +120°C
%RH range	<0.5 to 100%	<0.5 to 100%	10 to 100%
Min measured dew point @ 20°C	-40°C	-40°C	-10°C
Mirror material options	Gold plated copper (standard), gold stud, Platinum stud**		
Sensor body material options	Acetal (standard), high temperature PEEK, Anodized aluminum**		
Response speed	1°C/sec (1.8°F/sec) plus settling time		
Operating pressure	20 barg (290 psig) standard High pressure version: 250 barg (3625 psig) max		
Remote PRT			
Temperature measurement	4 wire Pt100, 1/10 DIN class B		
Accuracy	±0.1°C (±0.18°F)		
Cable length	2m (6.6ft) (250m (820ft) max)		
Optional Remote Pressure Sensor			
Measurement range	0 to 25 bara (0 to 377 psia)		
Accuracy	0.25% Full Scale		
Measurement units	psia, bara, KPa or MPag		
Pressure transducer thread	1/8" NPT		

Monitor							
Resolution	User-selectable to 0.001 dependant on parameter						
Measurement units	°C and °F for dew point and temperature %RH, g/m ³ , g/kg, ppm _v , %Vol, ppm _w (SF ₆), for calculated humidities						
Outputs	<table border="0"> <tr> <td>Analog</td> <td>3 channels, user selectable 4–20 mA, 0–20 mA or 0–1 V</td> </tr> <tr> <td>Digital</td> <td>Modbus RTU over USB and optionally Modbus RTU over RS232 or RS485, or Modbus TCP over ethernet.</td> </tr> <tr> <td>Alarm</td> <td>Two volt free changeover contacts, one process alarm, one fault alarm; 1 A @ 30 V DC</td> </tr> </table>	Analog	3 channels, user selectable 4–20 mA, 0–20 mA or 0–1 V	Digital	Modbus RTU over USB and optionally Modbus RTU over RS232 or RS485, or Modbus TCP over ethernet.	Alarm	Two volt free changeover contacts, one process alarm, one fault alarm; 1 A @ 30 V DC
Analog	3 channels, user selectable 4–20 mA, 0–20 mA or 0–1 V						
Digital	Modbus RTU over USB and optionally Modbus RTU over RS232 or RS485, or Modbus TCP over ethernet.						
Alarm	Two volt free changeover contacts, one process alarm, one fault alarm; 1 A @ 30 V DC						
HMI	5.7" LCD with touchscreen						
Data logging	SD Card (512Mb supplied) and USB interface SD Card (FAT-16) – 2Gb max. that allows 24 million logs or 560 days, logging at 2 second intervals						
Environmental conditions	-20 to +50°C (-4 to +122°F)						
Power Supply	85 to 264 V AC, 47/63 Hz						
Power Consumption	100 V A						
Mechanical Specifications							
Dimensions (instrument)	190 x 255 x 215mm (7.5 x 10.0 x 8.4") h x w x d						
Dimensions (sensor)	Ø45 x 128mm with M36 x 1.5-6g mounting thread						
Weight	4.2kg (9.26lbs)						
Cable lengths	3, 5 or 10m (9.8, 16.4 or 32.8ft)						
General							
Storage temperature	-40 to +60°C (-40 to +140°F)						
Detection system	Single optics detection system with auto adjustment						
Calibration	4-point traceable in-house calibration as standard; UKAS accredited calibrations optional – please consult Michell Instruments						

**Recommended for special applications only. Consult Michell Instruments before ordering.

Dimensions

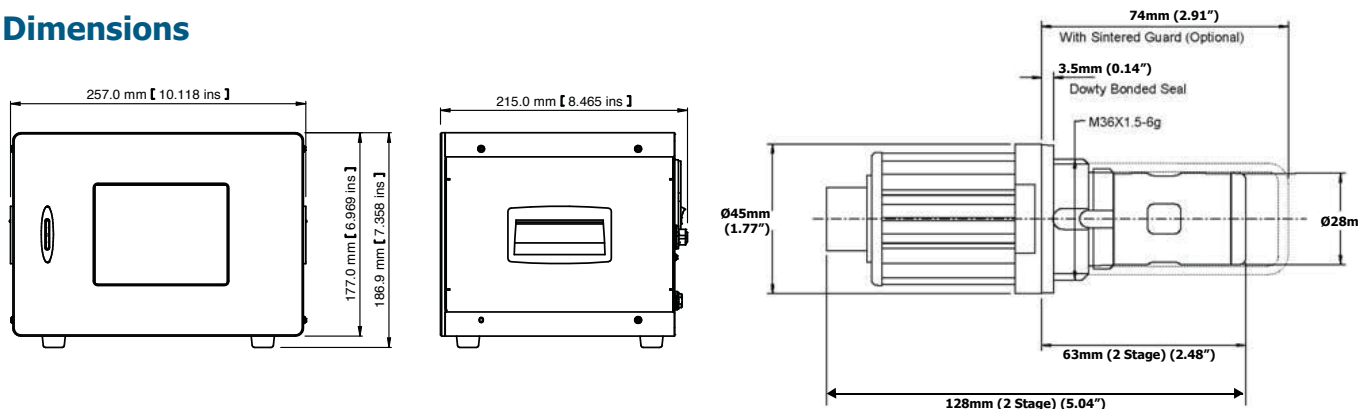

Michell Instruments 48 Lancaster Way Business Park, Ely, Cambridgeshire, CB6 3NW
Tel: +44 1353 658000, Fax: +44 1353 658199, Email: info@michell.com, Web: www.michell.com/uk

Michell Instruments adopts a continuous development programme which sometimes necessitates specification changes without notice.
Issue no: S8000 remote_97307_V4_UK_0318