



Advanced Test Equipment Corp.
www.atecorp.com 800-404-ATEC (2832)

CM-3CDEFT-32 Test System

Operations Manual

ThermoFisher
S C I E N T I F I C

CM-3CDEFT-32

Test System

Operations Manual

MA-95-632-005-00 REV B

Copyright 2011 Thermo Fisher Scientific Corporation
All Rights Reserved

Thermo Fisher Scientific Corporation
200 Research Drive
Wilmington, MA 01887-4442 USA
Tel: 978-275-0800
Fax: 978-275-0850
<http://www.thermo.com/esd>

The copyright protection afforded to Thermo Fisher Scientific Corporation includes all forms of media material and information including, without limitation, the software*, generated icons and logos etc. and all associated documentation. This operating manual and associated software contained within may not be duplicated in any way without the express permission of Thermo Fisher Scientific Corporation.

Printable products of the software such as test reports and graphs, and associated files of the same, are the property of the purchaser and may be subject to their own copyright restrictions.

*The software described in this manual may be copied by, strictly for the use of, the purchaser in accordance with the furnished license agreement.

™ Trademark Credits

IBM is a registered trademark of International Business Machines Corporation. Microsoft Windows and MS-DOS are registered trademarks of Microsoft Corporation.

Notice

In no event will Thermo Fisher Scientific Corporation be liable for any damages, consequential, incidental or indirect (including loss of business profits, business interruption, loss of business information, and the like) arising out of the use or inability to use the hardware or software supplied.

The author and publisher of the operating manual make no warranty of any kind, expressed or implied, with regard to the instructions and suggestions contained within. The author and publisher of this operating manual shall not be liable in any event of incidental or consequential damages in connection with, or arising out of, the furnishing, undertaking or use while following verbal or written instructions and suggestions in any interpretation of its contents.

Thermo Fisher Scientific Corporation's products undergo continuous development and the company reserves the right to change their specifications without obligation or prior notification.

**Thermo Fisher Scientific Corporation,
200 Research Drive
Wilmington, MA 01887-4442 USA
Tel: 978-275-0800
Fax: 978-275-0850
<http://www.thermo.com/esd>**

Amendment History

Issue	Date	Author	Amendment
A	8/26/2011	RRA	Initial Release
B	2/11/2014	MCL	ECN-012-14, CHANGE FUSE FROM 0.5A TO 1.0A, PAGE 20

TABLE OF CONTENTS

PRODUCT SAFETY	1
IMMUNITY TESTING GUIDELINES	3
SAFETY CONCERNS DURING IMMUNITY TESTING	4
INAPPROPRIATE USES	5
DESCRIPTION	6
INSTALLATION	7
Assembly Instructions	7
Voltage Selection	7
Cabling and Interconnections	7
Electrical Supply Requirements	10
Use of the CM-3CDEFT-32 with Ground-Fault Interrupters (GFI)	11
Physical Environment	12
Operating limits	12
Storage limits	12
Test Area Considerations and Site Preparation	13
Special Considerations for Immunity Testing	13
Special Considerations for EFT Testing	14
Handling, Transportation, Storage	14
Introduction	15
PROGRAMMING EFT	18
MAINTENANCE	20
Service and Maintenance Issues	20
Factory Inspection and Refurbishment	20
Calibration	20
Decommission Issues	20
TROUBLESHOOTING	21
Troubleshooting Guide	21

Product Safety

The following safety instructions have been included in compliance with safety standard regulations. Please read them carefully.

- **Read Instructions** -- Read all safety and operating instructions before operating the instrument.
- **Retain Instructions** -- Retain all safety and operating instructions for future reference.
- **Heed Warnings** - Adhere to all warnings on the instrument and in the operating instructions.
- **Follow Instructions** -- Follow all operating and use instructions.
- **Water and Moisture** -- Do not use the instrument near water.
- **Carts and Stands** -- Use the instrument only with a cart or stand that is recommended by the manufacturer or included as part of the CE Master system.
- **Wall or Ceiling Mounting** -- Do not mount the instrument on a wall or ceiling.
- **Ventilation** -- The instrument should be situated so that its location or position does not interfere with its proper ventilation. Do not install in a cabinet or other situation that may impede the flow of air through the ventilation openings.
- **Heat** -- The instrument should be situated away from heat sources such as heat registers or other instruments which produce heat.
- **Power Sources** -- Connect the instrument only to the type of power source described in the operating instructions or as marked on the instrument.
- **Grounding or Polarization** -- Take precautions to insure that the grounding of the instrument is not defeated. Operate only with grounded power cord.
- **Power Cord Protection** -- Place power supply cords so that they are not likely to be walked on or pinched by items placed on them or against them. Pay particular attention to cords at plugs, convenience receptacles, and the point where they enter and exit the instrument.
- **Cleaning** -- Clean the instrument only as recommended by the manufacturer.
- **Non-Use Periods** -- Unplug the power cord of the instrument when it will be left unused for a long period of time.
- **Lifting and Carrying** -- When moving or installing a **CM-3CDEFT-32** follow the instructions given in the Installation section of this manual; The **CM-3CDEFT-32** requires two people for moving.

-
- **Object and Liquid Entry** -- Take care that objects do not fall and that liquids are not spilled into the enclosure through openings.

- **Defects and Abnormal Stress** -- Whenever it is likely that the normal operation has been impaired make the equipment inoperable and secure it against further operation. Normal operation is likely to be impaired if, for example, the instrument:

Shows visible damage.

Fails to perform the intended function.

Has been subject to prolonged storage under unfavorable conditions.

Has been subjected to severe transport stresses.

- **Damage Requiring Service** -- The instrument should be serviced by qualified service personnel when:

The power supply cord or the plug has been damaged.

Objects have fallen or liquid has been spilled into the instrument.

The instrument has been exposed to rain.

The instrument does not appear to operate normally or exhibits a marked change in performance.

The instrument has been dropped, or the enclosure has been damaged.

- **Sitting or Climbing** -- Do not sit or climb upon the instrument or use it as a step or ladder.
- **Adapters, cables, and accessories** -- Use only adapters, cables, and accessories which have been approved for use with this unit.

Use only MultiContact Safety Plugs for connections to the front panel of the **CM-3CDEFT-32** – use of any other connections may result in risk of electric shock.

- **EUT load may restart automatically** -- The thermal protection within the **CM-3CDEFT-32** is self-resetting. In the event of an Overload, as indicated by the chassis-mount Overload indicator, switch the EUT power switch off or remove EUT Mains input and wait for Overload to clear.

The **CM-3CDEFT-32** 3-Phase Coupler/Decoupler is designed to operate with the Thermo Scientific **EMCPRO** series.

Use of the **CM-3CDEFT-32** with any other equipment may result in risk of electric shock, damage to equipment, and risk of fire.

Immunity Testing Guidelines

- **DO NOT WORK ALONE.**
- Do not use the equipment in conditions other than reasonable laboratory conditions. There should be no condensing humidity or water standing on the floor or work surfaces; there shouldn't be significant dust or other contamination.
- Ensure that **NO ONE** is touching the equipment under test (EUT) during the test or immediately after the test until AC power to the EUT has been turned off.
- Ensure that there is a **barrier** to act as protection in case the equipment under test explodes. This may happen due to power-follow¹ after a failure. The barrier should be interlocked to prevent surging and to disconnect all AC if the barrier is removed.
- The equipment under test must be surrounded by sufficient **insulating material** to withstand twice the surge voltage. Consider distance to the floor or table and walls if air is the insulating material.
- Ensure that the **proper supply mains** voltages are applied to both Thermo Scientific equipment and to the equipment under test, and that the AC branch circuit is capable of supplying the current.
- The ground (protective earth), neutral and phase lines of the AC supply to the equipment under test supply must be connected properly. **Do not defeat the protective earth connection.**
- The ground (protective earth), neutral and phase lines of the AC supply to the Thermo Scientific equipment must be connected properly. **Do not defeat the protective earth connection.**
- When surging a powered EUT, the mains supply to the equipment under test must be capable of handling the potential AC fault current (e.g. do not use a UPS to power the EUT).
- Use only equipment which is designed to be safe for the test being performed.
- Do not test in a potentially explosive atmosphere (e.g. gas fumes).
- Never use equipment that is operating in a strange manner, or that shows clear indication of abuse.
- If probes are in use, be sure they are differential probes which have no ground connection to the surged ground or to the equipment under test.

¹ Power-follow is a condition where the event causes a low-impedance path which full mains current may then flow through. One example of this is a gas-tube arrester, which maintains a high impedance until a event switches it to a low-impedance state; the low-impedance state is maintained until the mains voltage drops below a critical threshold. Similar effects can be seen due to electrical arcs or exploded components.

Safety Concerns During Immunity Testing

Immunity testing is hazardous. The equipment under test (EUT) can ignite, possibly explosively. Noxious, toxic and sometimes fatal fumes can be generated by the burning equipment. Accumulated gases may ignite explosively (i.e., *flashover*).

In an environment where Immunity testing takes place, it is absolutely crucial that these minimum safety precautions be taken:

- Immunity testing should be performed only by properly trained test personnel who are experienced in conducting such test, or be observed and supervised by such experienced personnel. No person subject to heart or neurological conditions should be allowed to conduct surge tests. Persons with pacemakers should not be allowed in or near the area where testing is conducted.
- Never leave a procedure or a test setup unattended.
- All personnel working in the area must be shielded with appropriate eye protection, body protection and electrical protection. They should not be allowed to work in a direct line of a possible explosion of the equipment under test.
- The test area should be a clear and unobstructed environment dedicated to such tests.
- The test area should be equipped with ventilating hoods and blowers to remove gases that may be caused by exploding or burning components.
- The test area should have nonflammable walls and floors plus shielding to contain exploding parts and flames.
- There must be fire extinguishers certified for use in electrical and chemical fires readily available at the test site. **DO NOT USE WATER TO EXTINGUISH AN ELECTRICAL FIRE.**
- All flammable materials and debris must be outside the test area, and the area must be well marked, preferably by physical barriers, to prevent accidental intervention by non-test personnel while a test is in progress.

Inappropriate Uses

The unit must be kept within the environmental limits of the operating requirements. This includes not using the unit in condensing humidity.

There are no User Serviceable parts inside; do not remove covers.

Use only adapters and cables and accessories which have been approved for use with this unit.

Connect only to Thermo Scientific equipment which has been approved for use with this unit. DO NOT connect to any other test equipment.

DO NOT modify front panel jumpers for multiple line Surge coupling.

Read and follow directions for connecting equipment.

Operating the **CM-3CDEFT-32** with any equipment other than those recommended may damage equipment, create a shock hazard, and create a fire risk!

Description

The **CM-3CDEFT-32** 3-Phase Coupler/Decoupler is a single-enclosure, floor-standing or desktop test system designed to couple EFT events to a 3-phase AC Mains. Single & Multiple line coupling for EFT per IEC standards with the Thermo Scientific EMCPRO *PLUS* Test System.

A Coupler/Decoupler is required to apply surge and EFT to the AC Mains of the Equipment Under Test. The Coupler/Decoupler connects the output of a surge generator to the EUT AC Mains [Coupler] and minimize surge or EFT energy which may couple to the AC Mains of the building [Decoupler].

The **CM-3CDEFT-32** is a manual tester, in which the EFT operation is programmed from the front panel via switches. Programming is fast and simple. Operation is semi-automatic when used with **EMCPro** series test equipment, a Personal Computer, and the **CEWare** software, where the **CEWare** software can provide pauses and prompt the operator to change switches.



Installation

Assembly Instructions

The **CM-3CDEFT-32** requires two people for unpacking. Check the packaging materials and follow any special unpacking instructions shipped with your unit. The **CM-3CDEFT-32** comes fully assembled.

Save all shipping materials (shipping boxes, foam pieces, bags, and special instructions) for possible future shipments. The original shipping materials must be used whenever the **CM-3CDEFT-32** is returned for service.

Carefully check all shipping materials for accessories which may be packaged with the **CM-3CDEFT-32**.

Voltage Selection

The **CM-3CDEFT-32** must be set for the mains voltage at your site. This is usually done before shipment, but must be checked before installation and use.

On the rear of the **CM-3CDEFT-32** check that the voltage select block is set to the proper mains voltage.

If not correct, remove line cord, pry the voltage select block from the inlet assembly using a small screw driver; rotate the block to the proper voltage, as shown to the right, and fully insert in holder.

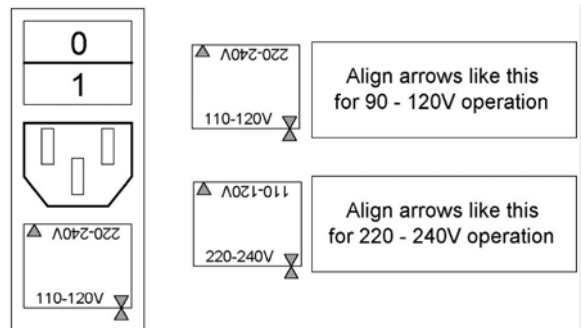

Cabling and Interconnections

The **CM-3CDEFT-32** can be placed alongside, placed on top or placed under an EMCPro.

The **CM-3CDEFT-32** has an AC Mains cord which plugs into the rear of the unit, via a standard IEC-320 connector. This provides fan and control power to the **CM-3CDEFT-32**, and is required for operation.

The EUT Power input is a pin and sleeve connector, rated for the current and voltage of the Equipment Under Test. A cord is provided to connect the **CM-3CDEFT-32** to the building AC mains.

A matching pin and sleeve connector for connection to the building mains must be provided by the customer, and installation of this connector may require the services of an electrician.

Connection to the Equipment Under Test -- the EUT Load

Connection to the Equipment Under Test (EUT) is via five safety sockets on the lower right of the **CM-3CDEFT-32** front panel. Five, unassembled safety socket connectors are provided with the **CM-3CDEFT-32**; additional connectors are available from MultiContact.

The cable to the Equipment Under Test must be built to the customer requirements. This wiring should be done to meet all applicable, local, safety requirements. In general -- but not exclusively -- these requirements include the following:

- The wiring to the EUT must be rated to withstand the applied mains voltage.
- The wiring to the EUT should be rated to withstand twice the applied pulse voltage, or the wiring should be isolated from the operator and ground so that insulation breakdown does not create a hazard.
- The wiring to the EUT should be rated for the expected fault current of the **CM-3CDEFT-32** (32 amperes) or additional current limiting and protection should be added.
- **WHERE CONNECTION TO PE IS REQUIRED FOR SAFETY, A PE CONNECTION *MUST* BE PROVIDED.**

It is considered good practice for the PE wired connection to be made longer than any of the other connections; in the event of an accidental disconnection, the PE terminal is disconnected last.

In addition, some loads may require proper phasing for proper operation. The user must determine the phase relationships of the building AC mains and check this relationship at the **CM-3CDEFT-32** outputs.

Caution

Construction and assembly of cord and connection of EUT loads should be done only by trained personnel with knowledge of electrical safety practices, and practical knowledge of the electrical and safety requirements of the load.

Connecting the EMCPro EFT Output to the CM-3CDEFT-32 Input

-
- The EFT cable connects the **CM-3CDEFT-32** EFT inlet to the **EMCPro** EFT-Output jack.
 - The cable is an HN-coax, which screws tight to each connection.
 - The maximum programmed EFT voltage should not exceed the 4400V rating of the **CM-3CDEFT-32** .

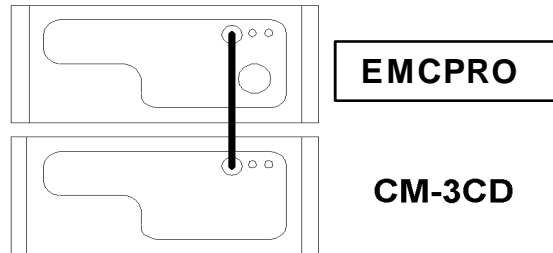

Direct Current Power to EUT

The **CM-3CDEFT-32** can accept a single-phase AC, or Direct Current (DC) power source at the EUT input and provide it to the EUT output. When connecting a single-phase or DC source it is important to note the assignment of EUT inlet and outlet connectors.

The **CM-3CDEFT-32** is internally protected at 32 or 16 amperes. When used with a single-phase AC, or Direct Current (DC) power source, if the EUT load or cabling requires current limiting protection of less than the **CM-3CDEFT-32** rating, it is the responsibility of the user to provide that protection.

Electrical Supply Requirements

The **CM-3CDEFT-32** system power is configured for one of two voltage ranges:

100 - 120 Vac, 50/60 Hz
220 - 240 Vac, 50/60 Hz

The voltage range configured is identified by label on the rear panel of the **CM-3CDEFT-32**. The voltage range may be easily changed with a screwdriver, following the directions of the **Installation, Voltage Selection** section of this manual.

The **CM-3CDEFT-32** is rated for EUT/ AC power source of:

CM-3CDEFT-32 250/433 Vac, 32 ampere, 3-phase, 5-wire, 50/60 Hz (U.S.) DC: 30A _{dc} up to 24V _{dc} ; 25A up to 48V; 8A up to 100V

The EUT, AC power source should be fused or protected for a maximum of 100 amperes.

The over current protection of the **CM-3CDEFT-32** includes detection of imbalanced phase-currents. When using the **CM-3CDEFT-32** with a one-phase load, a two phase load, or a load with extreme imbalance between phase currents, the over current protection will trip at a load current of 85% of the **CM-3CDEFT-32** rating.

The EUT power source must have adequate capacity for full power-follow² in the event that testing causes an equipment failure. Using a supply without sufficient capacity may result in a failure being masked.

Acceptable power sources include:

- * A dedicated branch circuit
 - * The dedicated output of a motor-generator (MG) set.
 - * The output of a properly rated and installed isolation transformer.

² Power-follow is a condition where the pulsed event causes a low-impedance path through which fault level mains current may then flow: possibly hundreds of amperes or greater. One example of this is a gas-tube arrestor, which maintains a high impedance until a surge event switches it to a low-impedance state; the low-impedance state is maintained until the mains voltage drops below a critical threshold. Similar effects can be seen due to electrical arcs or exploded components.

Use of the CM-3CDEFT-32 with Ground-Fault Interrupters (GFI)

Problems may result when using the **CM-3CDEFT-32** on AC mains protected by Ground-Fault Interrupters (GFIs).

The problem is due to a clamp circuit, protecting the building Mains from excessive voltage during surge, and from the coupling network which connects the generator to the AC mains during the event, and creates a short pulse of mains current in PE, tripping the GFI.

There are two solutions to this problem:

- * The first solution is to power the EUT from a source that does not have a GFI device installed. This solution may not be practical in some locations due to building codes or safety regulations.
- * The second solution is to install an isolation transformer between the AC mains and **CM-3CDEFT-32**. The isolation transformer should be rated for the current of the EUT load.

Note

A solid-state regulated line source such as an uninterruptable power supply (UPS) or a power frequency amplifier will generally not have the instantaneous capacity or full power-follow required for Surge and PQF testing, and therefore should not be used as the AC power source for any equipment being tested.

Physical Environment

The **CM-3CDEFT-32** systems are intended for operation in a laboratory environment, protected from excess dust, humidity, and temperature.

- * No condensing humidity or standing water on the floor or work surfaces.
- * No significant dust or other contamination.

Operating limits

Temperature:	15 - 40° C
Humidity:	10 - 85%, non-condensing
Altitude:	10,000 feet max.

Storage limits

Temperature:	0 - 60° C
Humidity:	10 - 90%, non-condensing
Altitude:	10,000 feet max.

Test Area Considerations and Site Preparation

Conduct Immunity testing under sound laboratory conditions. Verify the following:

- No condensing humidity or standing water on the floor or work surfaces
- No significant dust or other contaminants
- Clear and unobstructed vision
- Adequate ventilation, including ventilating hoods and blowers to remove gases
- Nonflammable walls and floors
- Barriers surrounding the EUT to contain exploding parts and flames
- Appropriate fire extinguishers for electrical and chemical fires. **DO NOT USE WATER TO EXTINGUISH AN ELECTRICAL FIRE.**
- No flammable materials or debris inside the test area. The area must be well marked, preferably by physical barriers
- Keep unauthorized personnel out of the area during testing

Allow at least six inches clearance from the wall or other equipment on both sides of the instrument for proper air flow. The system must be mounted on a level surface.

For EFT testing the EFT generator and **CM-3CDEFT-32** should be mounted on the floor, on the ground reference plane. For other testing, the EFT generator and **CM-3CDEFT-32** may be placed on a table that can support the weight of the units. They may also be placed on a sturdy cart. However, since the unit is heavy, make certain that the instrument and cart combination is stable, and cannot be easily tipped - particularly if the wheels strike a bump on the floor such as the edge of a rug, a pebble or a small piece of hardware.

Special Considerations for Immunity Testing

Immunity testing is best done in an area cleared of obstructions. Clearly mark the boundaries of the area.

There is the possibility that the surge may flash over to circuits or metal objects not directly under test, and that components in the equipment being tested may explode or ignite under the stress of the test. Whenever possible, enclose the equipment under test within a fireproof and explosion-proof barrier having insulation capable of withstanding at least twice the maximum surge voltage.

Never allow direct line-of-site view of components that may explode or ignite. If visual observation is required, use a robust transparent barrier of suitable thickness for protection.

Immunity testing should only be carried out by fully trained personnel who are informed of the hazards of such testing, and who have full control over all of the test equipment in the area.

Special Considerations for EFT Testing

EFT testing involves the use of very high frequency pulses. For this reason the testing standards specify the use of a ground reference plane in the area where EFT testing is performed. In addition, the standards specify the minimum and maximum spacings among the various equipment present in the test area.

This device complies with the requirements of the EMC Directive, 89/336/EEC, as stated in the declaration of Conformity. However, EFT test pulses are by nature an interference test and can therefore create a possible source of disturbance to other electronic equipment that is not intended for test. This device should be used in an environment free of other equipment that could be affected by these emissions, or in a shielded room.

The floor of the test area is to be covered with copper or aluminum with a minimum thickness of 0.01 inch, which must be bonded to building Protective Earth (PE) ground. In addition, the cabinet of the EFT generator and **CM-3CDEFT-32** must be directly tied to the ground reference plane. Provision for a mounting bracket is made on the rear and bottom of the **CM-3CDEFT-32** and the bracket and screws are provided.

See the **EMCPRO** manual, for further information on EFT testing.

Handling, Transportation, Storage

Save all shipping materials (shipping boxes, foam pieces, bags, and special instructions) for possible future shipments.

The **CM-3CDEFT-32** requires two people for unpacking. Follow the instructions in the **INSTALLATION** section of this manual and any special instructions shipped with the unit.

Issues related to transportation of **CM-3CDEFT-32** models are identical to those for installation; the weight of the unit requires that two people help in packing and movement. When packing the unit for transportation the original shipping materials should be used, or new materials of equivalent strength and durability.

For long storage intervals, unplug the power cords of the instrument and cover the instrument to protect from dust and liquid spills.

Introduction

A Coupler/Decoupler is required to apply surge and EFT to the AC Mains of the Equipment Under Test. The Coupler/Decoupler connects the output of a surge generator to the EUT AC Mains [Coupler] and minimize surge or EFT energy which may couple to the AC Mains of the building [Decoupler].

The circuitry to perform this is very simple. The generator is connected to the EUT output. Filter inductors and capacitors in each line attenuate EFT and surge energy and reduce the amount of energy escaping into the building AC Mains.

The complications in this circuitry are in the details: constructing filter inductors which can block the volt-second product of a 6000 volt, 1.2x50uS pulse, yet which have very low coupling capacitance to avoid passing EFT energy. They must also safely couple the surge or EFT generator to a high-voltage AC Mains.

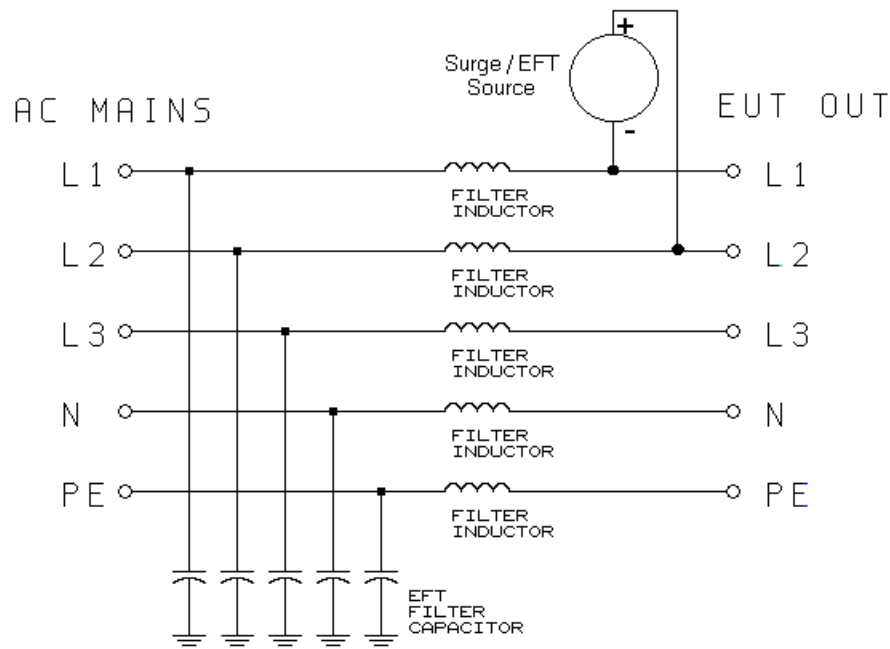

Basic De-Coupler Network

For EFT, the **CM-3CDEFT-32** is designed to operate with the **EMCPro** series. The coupling network required to connect the surge to the AC Mains is built into the **CM-3CDEFT-32**.

Operating the **CM-3CDEFT-32** with any equipment other than those recommended may damage equipment, create a shock hazard, and create a fire risk!

The **CM-3CDEFT-32** is programmed from the front panel, and all connections to the Equipment Under Test (EUT) are made from the front panel. The front panel controls and features are broken into three major groups: **EMCPro** to **CM-3CDEFT-32** Interconnections, Equipment Under Test Connections and the User Interface (Programming).



EMCPro to **CM-3CDEFT-32** Interconnections

From the front Panel of the **EMCPro** and **CM-3CDEFT-32** an HN-coax connects the **CM-3CDEFT-32** EFT inlet to the **EMCPro** EFT Output to CCL jack.

This cable screws tight to each connection. Maximum programmed voltage should not exceed the rating of the **CM-3CDEFT-32** -- 4400V).

Equipment Under Test Connections:

Connection to the Equipment Under Test (EUT) is via five safety sockets on the lower right of the **CM-3CDEFT-32** front panel. Five, unassembled safety socket connectors are provided with the **CM-3CDEFT-32**; additional connectors are available from MultiContact.

The cable to the Equipment Under Test must be built to the customer requirements. This wiring should be done to meet all applicable, local, safety requirements. In general -- but not exclusively -- these requirements include the following:

- * The wiring to the EUT must be rated to withstand the applied mains voltage.
- * The wiring to the EUT should be rated to withstand twice the applied pulse voltage, or the wiring should be isolated from the operator and ground so that insulation breakdown is not a problem.
- * The wiring to the EUT should be rated for the expected fault current of the **CM-3CDEFT-32** (32 amperes) or additional current limiting and protection should be added.
- * **WHERE CONNECTION TO PE IS REQUIRED FOR SAFETY, A PE CONNECTION *MUST* BE PROVIDED.**

User Interface (Programming)

Feedback to the operator is provided by three indicators on the front of the unit:

- * **SYSTEM POWER** is lit when the unit is powered -- the rear power switch is set to ON and the system power cord connected. This indicator must be lit for the unit to operate.
- * **EUT POWER** is lit when the EUT power switch on the front panel is set to ON -- the EUT is energized.
- * **OVERLOAD** is lit when there is an over temperature or over current fault and the EUT power switch on the front panel is set to ON. The unit will not operate while this indicator is lit.

Warning! EUT load may restart automatically!

The thermal protection within the **CM-3CDEFT-32** is self-resetting. In the event of an Overload, as indicated by the chassis-mount Overload indicator, switch the EUT power switch off or remove EUT Mains input and wait for Overload to clear.

Programming EFT

To program EFT, first connect the **CM-3CDEFT-32** and EFT generator using the coax cable provided with the **CM-3CDEFT-32**.

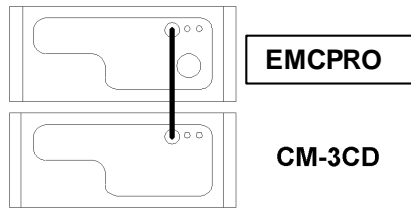

Connect EFT Output on the EFT generator to the coax connector of the **CM-3CDEFT-32**. Use the cables supplied with the **CM-3CDEFT-32** -- do not substitute. The EFT cable should be disconnected from both the **CM-3CDEFT-32** and the EFT generator when not performing tests.

The **CM-3CDEFT-32** supports single-line to 5-line COMMON MODE EFT coupling per IEC 61000-4-4.

The **CM-3CDEFT-32** is manually programmed by setting the EFT COUPLING MODE switches to the desired coupling mode. The EFT can be coupled from 1 to 5 lines (**L1, L2, L3, N, PE**) in any combination.

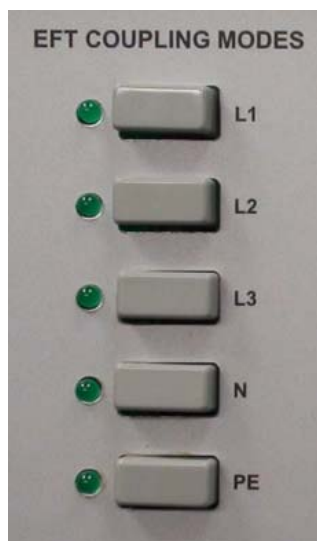

All EFT events are with respect to the ground plane. The polarity of the event is always as set at the EFT generator.

NOTE!

EMCPRO **Firmware v6.00** and up adds two new output modes for EFT testing to accommodate separate calibrations for using the CM3CDEFT external coupler/decoupler in **Normal** and **Common mode**.

The previously-labeled "Direct" output mode has been changed to "CCL" (the capacitive coupling clamp), because all three modes use the "Direct" output connector.

Programming EFT

For **CM-3CDEFT-32** EFT operation the **EMCPRO** must be programmed with **Output: Coupling** set to --- **CM3CD NORMAL** or **CM3CD COMMON**. Depending if performing single line or multiple line testing.

This sets the EFT output to the **EMCPRO** front panel coax connector.

```
| EFT/B: USER DEF |||EUT OFF|
Voltage ..... +4000 V
BurstFrequency .... 5.0kHz
Output:Coupling ... CM3CD COMMON(NORMAL)
Duration ..... 60 s
RUN ||| ||| ||| ||| ↑ ||| ↓ |||EXIT
```

For all pre-programmed tests, remember that you are only testing the single coupling mode that you have programmed at the **CM-3CDEFT-32** front panel. In many cases, for a complete test, you will have to change coupling mode and continue until all modes have been tested.

The **CM-3CDEFT-32** is a manual unit. it is programmed by switches on the front panel. Since the **EMCPro** is an automatic unit, some care must be taken on interfacing the two units and in programming. The **CEWare** software provides pauses and prompt features which can prompt the operator with pre-programmed messages and instructions for setting the **CM-3CDEFT-32** switches, allowing semi-automatic testing.

Maintenance

Service and Maintenance Issues

There are no user serviceable parts within the **CM-3CDEFT-32**. Service is solely by Thermo Fisher Scientific trained, authorized technicians.

The system power connector contains a fuse block, holding two, 5mm, 1.0A 250V time-delay fuses. These may be replaced by removing the mains cordset from the power connector and prying the cover off the fuse holder with a small screw driver.

Factory Inspection and Refurbishment

Factory Inspection and Refurbishment is available. Consult factory for terms and conditions.

Calibration

Yearly calibration of the **CM-3CDEFT-32** is recommended.

Decommission Issues

There are no hazardous materials within the **CM-3CDEFT-32** and no special issues in decommissioning.

Troubleshooting

This section aids in finding and solving any problems you may experience.

Troubleshooting Guide

In the event of a problem with the **CM-3CDEFT-32** please follow the following procedure.

- * Verify that you have properly selected all test parameters on the **EMCPRO**.
- * Check that the **CM-3CDEFT-32** and **EMCPRO** are properly connected to the AC Mains.
- * Check that the EUT is properly connected to the **CM-3CDEFT-32**.
- * Check all interconnections for loose connections.
- * Try cycling power to the EUT, **EMCPRO** and **CM-3CDEFT-32**.
- * Check the following trouble-shooting guide, for your symptoms.
- * Contact Customer Service for guidance.

CM-3CDEFT-32 Troubleshooting Guide

The EUT cannot be powered	Check that: <ul style="list-style-type: none">* The SYSTEM POWER indicator is lit.* The SYSTEM POWER switch is ON (rear)* The System power line cord is inserted and connected to the building AC mains* The OVERLOAD indicator is not lit* The EUT POWER switch is ON* The EUT POWER indicator is lit
The OVERLOAD indicator is lit	<p>Either there was an over-current condition on the EUT load, or an internal over temperature condition within the unit. Both conditions are self-resetting.</p> <p>Turn the EUT POWER switch to off. Check the EUT load for possible shorts. Check that the units fans are operating. Wait 2 minutes and retry the EUT POWER switch.</p> <p>WARNING! If the EUT POWER switch is ON, the EUT may start unexpectedly when the over temperature condition resets.</p>
The SYSTEM POWER indicator is NOT lit.	Check that: <ul style="list-style-type: none">* The SYSTEM POWER switch is ON (rear)* The System power line cord is inserted and connected to the building AC mains* The voltage configuration block in the System power inlet receptacle is set to the proper Mains voltage.* The fuses in the System power inlet receptacle are good.

Filing a Problem Report

When reporting a problem to Thermo Fisher Scientific Customer Service, please include the serial number and model number from the rear panel of the **CM-3CDEFT-32**.

Mail, Fax or phone your problem report to:

Customer Service
Thermo Fisher Scientific Corporation,
200 Research Drive
Wilmington, MA 01887-4442 USA
Tel: 978-275-0800
Fax: 978-275-0850
<http://www.thermo.com/esd>

or your local, authorized service representative.

WEEE Compliance:

This product is required to comply with the European Union's Waste Electrical and Electronic Equipment (WEEE) Directive 2002/96/EC. It is marked with the following symbol:

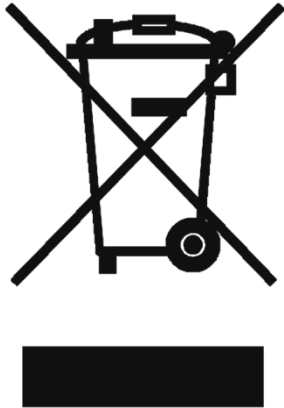

Thermo Fisher Scientific has contracted with one or more recycling/disposal companies in each EU Member State, and this product should be disposed of or recycled through them. Further information on Thermo Fisher Scientific's compliance with these Directives, the recyclers in your country, and information on Thermo Fisher Scientific products which may assist the detection of substances subject to the RoHS Directive are available at [**www.thermo.com/WEEERoHS**](http://www.thermo.com/WEEERoHS)