



Technical
Specifications

PIPESCAN HD

Mapping the unseen

The Pipescan™ HD solution is designed to maximize speed, reliability and confidence for detection of defects such as corrosion and pittings in ferrous pipes and surfaces.

SIMPLE, EFFECTIVE, CORROSION MAPPING

The Pipescan HD is the highest resolution Magnetic Flux Leakage (MFL) scanner on the market. With a high Probability of Detection (PoD), the Pipescan HD is an effective and reliable pipe inspection solution for corrosion and pitting detection.

Pipescan deployment is easy with the unique single curvature adjustment tool allowing for a quick inspection setup. No couplant or complicated gate settings are required, connect the Pipescan to the data acquisition instrument, enter inspection details, and the system is ready to go.

Furthermore, all scanned data is automatically recorded and reports can be issued on the spot, giving asset owners immediate visibility on the health condition of their assets, enhancing productivity and efficiency.

WHY MAGNETIC FLUX LEAKAGE (MFL)?

MFL is a rapid, reliable, and robust corrosion screening technique that detects the volume of missing magnetic material in a component under inspection.

MFL requires limited surface preparation and no couplant is needed. Users require minimal training, and with scanning speeds up to 1m/s (3.2 ft/s), MFL is the ideal solution for fast, cost-effective corrosion detection.

The Eddyfi Technologies Pipescan HD solution is designed to maximize speed, reliability, and confidence for the detection of corrosion and pitting in ferrous pipes and surfaces. It increases the total efficiency of integrity assessment campaigns by enhancing the productivity of the inspection team, optimizing the workflow to include on-the-spot reporting, and providing the asset owner with verifiable, recorded data.

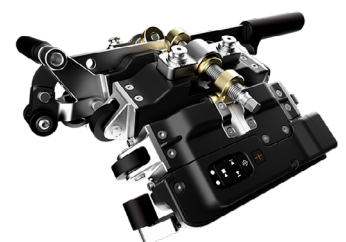

PORTABLE, BATTERY-POWERED SOLUTION FOR RAPID CORROSION DETECTION WITH DATA COLLECTION

One-man operation, high Probability of Detection (PoD) compared to traditional spot readings, easy to understand results with minimal training.

ADJUSTABLE REPORTING THRESHOLD

Keeping with the goal of a fast and easy to use solution, the software has retained the adjustable reporting threshold feature, allowing the user to only report on what is relevant to the work scope. As all the data is recorded, the reporting threshold can be adjusted post-inspection. By retaining all the data, engineers have the knowledge to make reliable maintenance decisions.

REPORT ON THE GO

Efficiency tools include a one-click reporting tool designed to improve the overall workflow from inspection to report. Indications can be analyzed on the go, at the end of a scan or the end of a job. Once the analysis has been completed, simply select "generate report", then transfer to a USB for distribution. Once the inspection is finished, so is the report.



Figure 1: Pipescan HD deployment inspecting pipe for corrosion.

FEATURES

- Speed: scanning, data analysis, and reporting
- Highest resolution on the market offering easy to understand C-scan imaging
- High probability of corrosion detection with defects down to 1mm (0.04in) identified
- Full data recording with adjustable reporting threshold feature
- Simple in-service deployment: No couplant and minimal surface preparation required
- Easy to operate with minimum training required
- Flexible heads fit a full range of pipe and vessel sizes

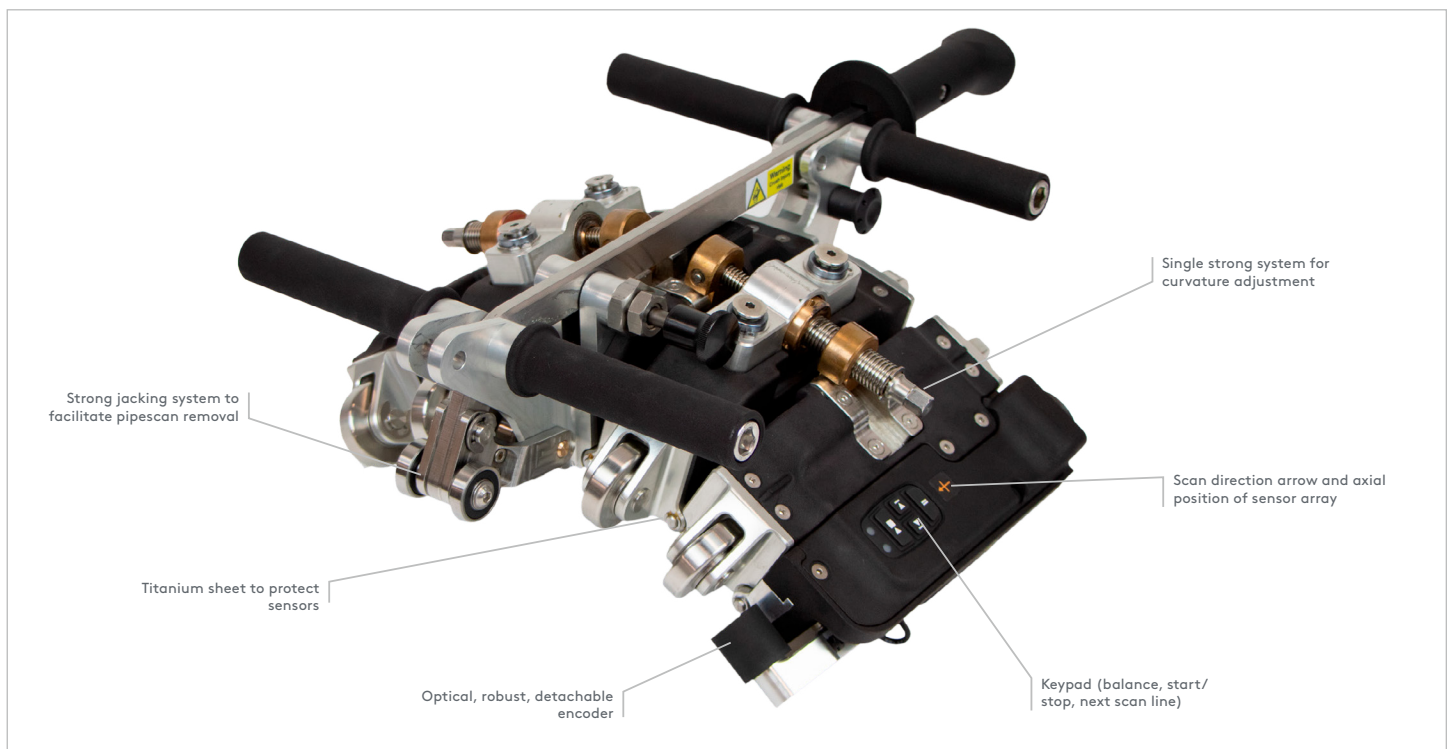

Figure 1: Annotated breakdown of Pipescan HD.

SPECIFICATIONS

PIPESCAN PERFORMANCE

	PS-HD-MFL-127XFLAT	PS-HD-MFL-73X127	PS-HD-MFL-48X6
Technology	Magnetic Flux Leakage/Hall Effect Sensors		
Method of propulsion	Hand Push Speed up to 1m/sec (40in/sec)		
OD range (real value)	127mm to flat (5.0in to Flat)	73mm to 127mm (2.875in to 5in)	48mm to 64mm (1.9in to 2.5in)
Max recommended wall thickness	Up to 12.7mm (0.5in)	Up to 8.56mm (0.337in)	Up to 6.05mm (0.238in)
Maximum coating thickness	6mm (0.24in) non magnetic material		
Number of channels	27	17	9
Channel spacing	7mm (0.27in)		
Smallest detectable defect	2 mm diameter defect at 10% wall loss		
Maximum surface temperature	60°C (140°F)		
Connecting cable	5m (15ft) standard length		
Weight	20.5lb (9.3kg)		
Transit case	Meets IATA requirements for transporting magnetizable material		
Compatible Instruments	Swift-M, Reddy-32M		

DIMENSIONS

	PS-HD-MFL-127XFLAT	PS-HD-MFL-73X127	PS-HD-MFL-48X6
C: Profile clearance	115mm (4.5in)	100mm (4in)	100mm (4in)
W: Maximum width	317mm (12.4in)	242mm (9.5in)	173mm (6.8in)
L: Length	454mm (17.8in)	425mm (16.7in)	409mm (16.1in)

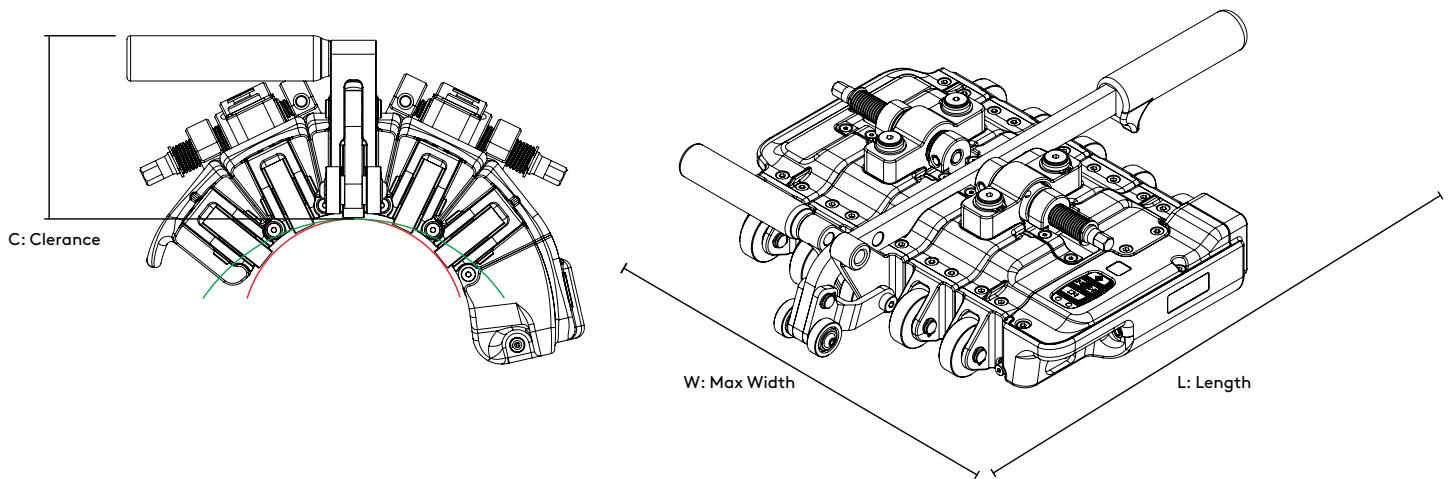

The information in this document is accurate as of its publication. Actual products may differ from those presented herein. ©2024 Eddyfi Technologies, Pipescan, Swift, Reddy, and their associated logos are trademarks or registered trademarks of Eddyfi Canada, Inc. in the United States and/or other countries. Eddyfi Technologies reserves the right to change product offerings and specifications without notice. Eddyfi Technologies is a Previaan Business Unit.