



## PNA-X Pro Vector Network Analyzer

NA5202A 10 MHz to 26.5 GHz

NA5204A 10 MHz to 43.5 GHz

NA5205A 10 MHz to 50 GHz

### Introduction

The NA5202A/4A/5A PNA-X Pro network analyzers simplify frequency-translating component testing with the source-per-port feature. This highly configurable instrument includes four ultra-low phase noise and low-harmonic signal sources, two low-noise receivers, and two combiners in a single test setup. Switchable front-panel loops on the source path and direct receiver access reduce the cabling required for complex high-power testing — and the associated signal power losses. Additionally, this integrated hardware eliminates the need for external signal generators and switches in the test setup. Consolidate your design verification setup while minimizing test cycle time and the potential for errors with the new source-per-port PNA-X Pro.



# Table of Contents

- Definition ..... 3
- Dynamic Range..... 5
- Corrected System Performance..... 6
- Uncorrected System Performance ..... 14
- Test Port Output..... 16
- Test Port Input..... 24
- Noise Receiver Input..... 31
- General Information ..... 34
- PNA-X Test Set Configuration Details ..... 38
- Literature Information..... 48
- Web Resources..... 48
- Keysight Support Services ..... 49

# Definition

## Specification (spec) <sup>1</sup>

Warranted performance. Specifications include guardbands to account for the expected statistical performance distribution, measurement uncertainties, and changes in performance due to environmental conditions. All specifications and characteristics apply over a  $25\text{ °C} \pm 5\text{ °C}$  and relative humidity of 25 to 70% range (unless otherwise stated).

The following conditions must be met:

- Instrument has been turned on for 90 minutes with VNA application running.
- Instrument is within its calibration cycle.
- Instrument remains at a stable surrounding environment temperature (between  $0\text{ °C}$  to  $40\text{ °C}$ ) for 60 minutes prior to turn-on.

## Characteristics (char.)

A performance parameter that the product is expected to meet before it leaves the factory, but that is not verified in the field and is not covered by the product warranty. A characteristic includes the same guardbands as a specification.

## Typical (typ.)

Expected performance of an average unit at a stable temperature between  $25\text{ °C} \pm 5\text{ °C}$  for 60 minutes prior to turn-on and during operation; does not include guardbands. It is not covered by the product warranty. The instrument must be within its calibration cycle.

## Nominal (nom.)

A general, descriptive term or design parameter. It is not tested, and not covered by the product warranty.

## Supplemental Information

A performance parameter that is tested on sampled product during design validation. It does not include guardbands and is not covered by the product warranty.

## Calibration

The process of measuring known standards to characterize an instrument's systematic (repeatable) errors.

**Corrected (residual)**

Indicates performance after error correction (calibration). It is determined by the quality of calibration standards and how well "known" they are, plus system repeatability, stability, and noise.

**Uncorrected (raw)**

Indicates instrument performance without error correction. The uncorrected performance affects the stability of a calibration.

1. For all tables in this data sheet, the specified performance at the exact frequency of a break is the degraded value of the two specifications at that frequency.

# Dynamic Range

The specifications in this section apply to measurements under the following conditions:

- 10 Hz IF bandwidth
- No averaging applied to data
- Does not include crosstalk effects

**Table 1. System dynamic range at test port**

## NA5202A

Frequency band	Low gain mode		High gain mode	
	Spec (dB)	Typical (dB)	Spec (dB)	Typical (dB)
10 MHz – 45 MHz	86	91	96	100
45 MHz – 141 MHz	104	109	116	121
141 MHz – 582 MHz	115	121	131	136
582 MHz - 2.234 GHz	126	132	144	149
2.234 GHz – 7 GHz	130	135	146	151
7 GHz - 9 GHz	128	133	143	148
9 GHz - 12.55GHz	126	131	143	148
12.55 GHz - 14 GHz	126	131	140	146
14 GHz - 21.25 GHz	124	129	140	146
21.25 GHz - 24.5 GHz	121	127	137	143
24.5 GHz - 26.5 GHz	116	123	132	140

## NA5204A/NA5205A

Frequency band	Low gain mode		High gain mode	
	Spec (dB)	Typical (dB)	Spec (dB)	Typical (dB)
10 MHz - 45 MHz	85	91	95	101
45 MHz - 141 MHz	102	109	115	122
141 MHz - 582 MHz	116	122	133	138
582 MHz - 7 GHz	125	133	144	150
7 GHz - 9 GHz	125	133	144	149
9 GHz - 14 GHz	123	129	140	145
14 GHz - 21.25 GHz	120	126	137	142
21.25 GHz - 26.5 GHz	128	134	144	150
26.5 GHz - 30 GHz	128	134	142	148
30 GHz - 35 GHz	124	131	139	145
35 GHz - 42.5 GHz	118	125	134	140
42.5 GHz - 50 GHz <sup>1</sup>	116	123	130	138

1. NA5204A is up to 43.5 GHz.

# Corrected System Performance

The specifications in this section are valid for temperatures of  $23^{\circ}\pm 3^{\circ}\text{C}$  and  $< 1^{\circ}\text{C}$  deviation from the calibration temperature.

Note: For any  $S_{ii}$  reflection measurement:

- $S_{jj} = 0$ .

For any  $S_{ij}$  transmission measurement:

- $S_{ji} = S_{ij}$  when  $S_{ij} \leq 1$
- $S_{ji} = 1/S_{ij}$  when  $S_{ij} > 1$
- $S_{kk} = 0$  for all  $k$

Corrected performance tables calculated using uncertainties with a coverage factor  $k = 2$ .

Uncertainty plots: power level of -15 dBm, 10 Hz IF bandwidth, no averaging. Includes uncertainties due to noise, compression, and dynamic accuracy. Coverage factor  $k = 2$

# Table 2. 85052G Calibration kit with Option CDA - Specification (dB)

NA5202A

	10 MHz to 2 GHz	2 GHz to 3 GHz	3 GHz to 8 GHz	8 GHz to 20 GHz	20 GHz to 26.5 GHz
<b>Directivity</b>	55	59	60	52	49
<b>Source Match</b>	42	41	36	33	31
<b>Load Match</b>	55	58	55	48	42
<b>Reflection Tracking Magnitude</b>	±0.015	±0.005	±0.015	±0.028	±0.031
<b>Transmission Tracking Magnitude</b>	±0.002	±0.002	±0.006	±0.019	±0.043

### Transmission Uncertainty

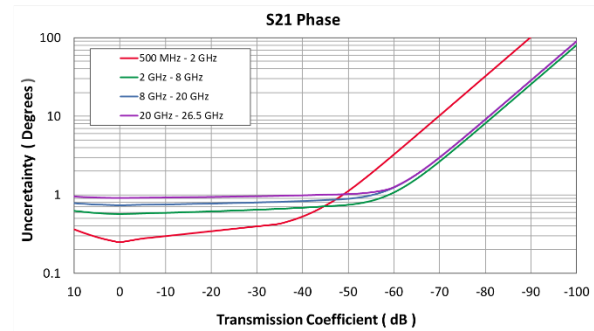
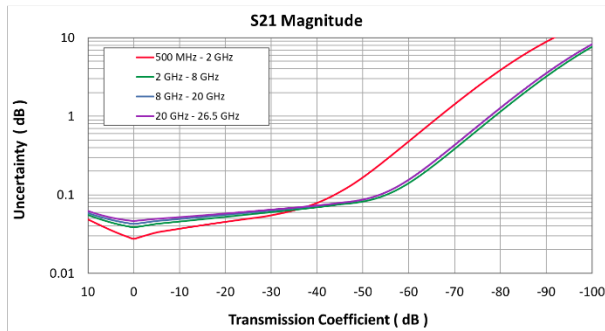

### Reflection Uncertainty

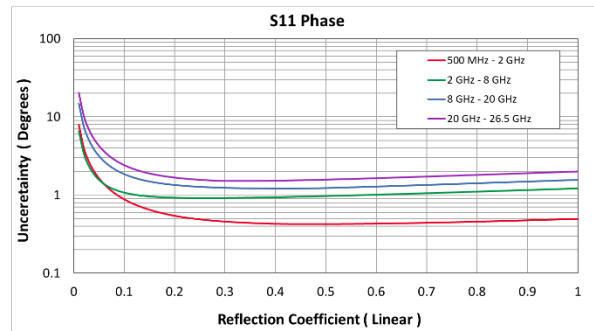
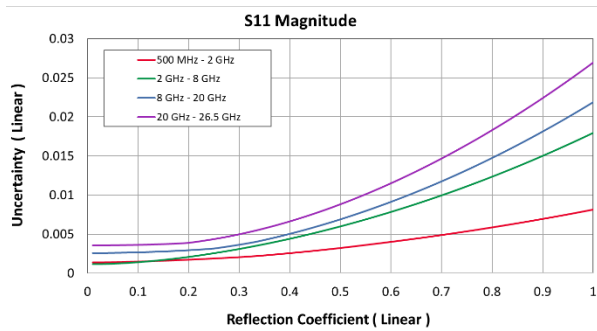

**Table 3. 85052G Calibration kit without Option CDA - Specification (dB)**

	10 MHz to 2 GHz	2 GHz to 3 GHz	3 GHz to 8 GHz	8 GHz to 20 GHz	20 GHz to 26.5 GHz
<b>Directivity</b>	46	44	38	36	34
<b>Source Match</b>	42	40	34	32	30
<b>Load Match</b>	46	44	38	36	33
<b>Reflection Tracking Magnitude</b>	±0.004	±0.007	±0.016	±0.021	±0.025
<b>Transmission Tracking Magnitude</b>	±0.004	±0.004	±0.011	±0.026	±0.062

**Transmission Uncertainty**

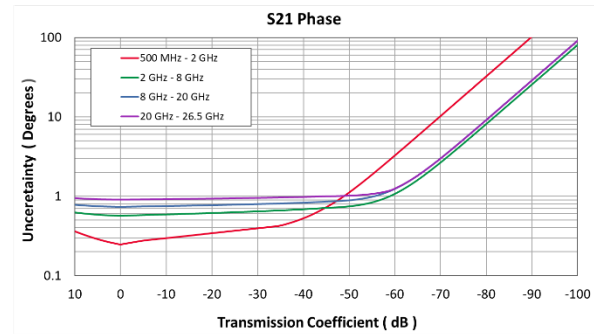
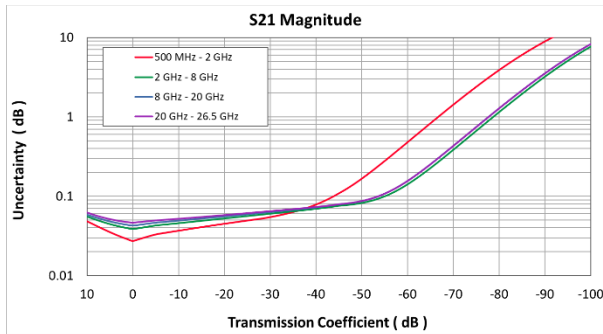

**Reflection Uncertainty**

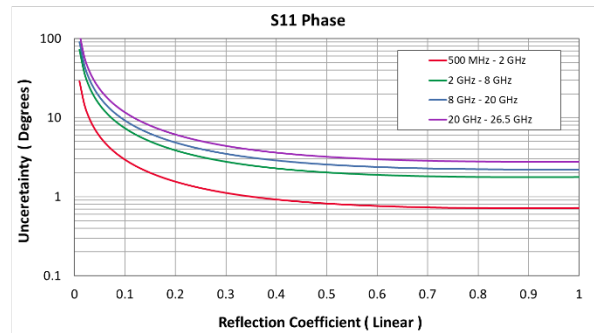
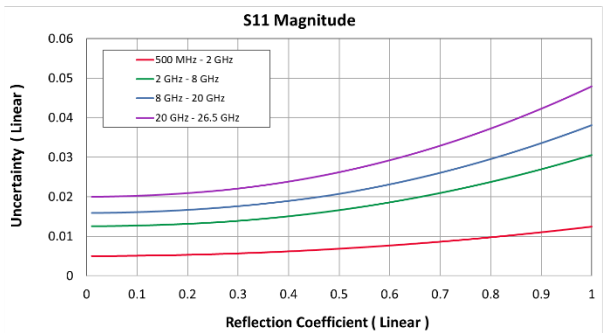
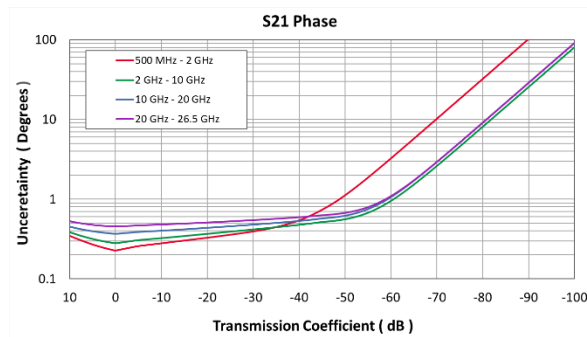
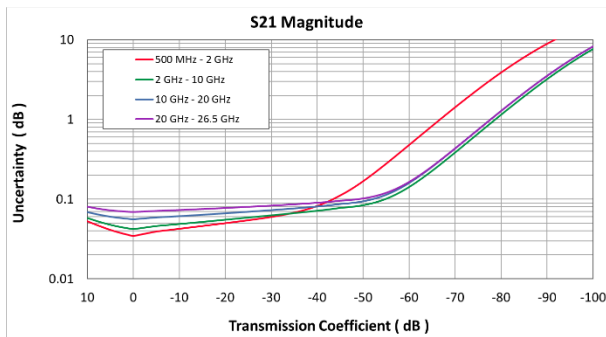



**Table 4. N4691D ECal module with Option 003 or 0DC - Specification (dB)**

	10 MHz to 500 MHz	500 MHz to 2 GHz	2 GHz to 10 GHz	10 GHz to 20 GHz	20 GHz to 26.5 GHz
<b>Directivity</b>	46	47	46	43	41
<b>Source Match</b>	41	47	45	42	40
<b>Load Match</b>	41	47	45	42	40
<b>Reflection Tracking Magnitude</b>	±0.05	±0.02	±0.03	±0.04	±0.05
<b>Transmission Tracking Magnitude</b>	±0.05	±0.02	±0.03	±0.04	±0.05

**Transmission Uncertainty**



**Reflection Uncertainty**

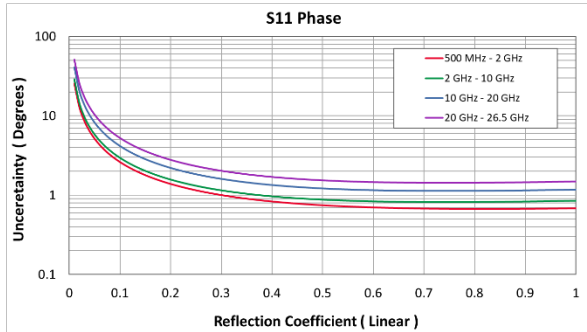
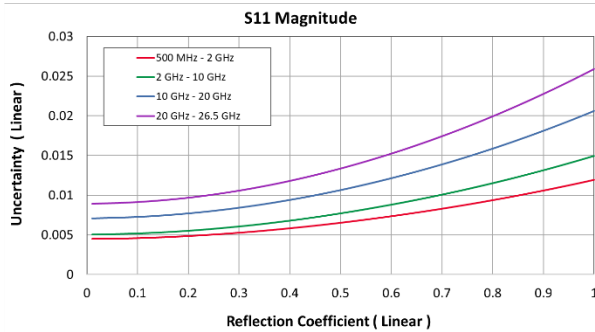

# Table 5. 85056G Calibration kit with Option CDA - Specification (dB)

NA5204A/5A

	10 MHz to 4 GHz	4 GHz to 20 GHz	20 GHz to 26.5 GHz	26.5 GHz to 50 GHz
<b>Directivity</b>	51	47	44	37
<b>Source Match</b>	41	36	34	29
<b>Load Match</b>	51	48	46	39
<b>Reflection Tracking Magnitude</b>	±0.012	±0.026	±0.041	±0.118
<b>Transmission Tracking Magnitude</b>	±0.006	±0.009	±0.022	±0.024

### Transmission Uncertainty

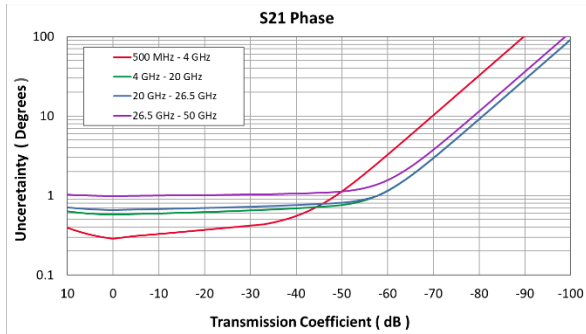
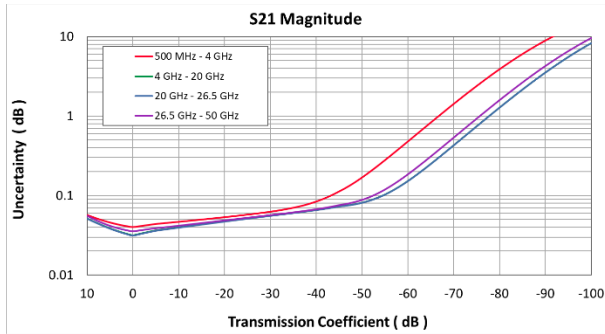

### Reflection Uncertainty

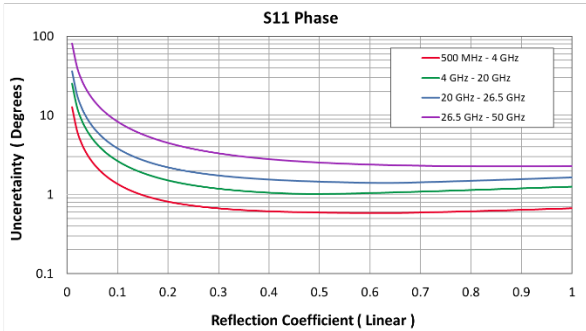
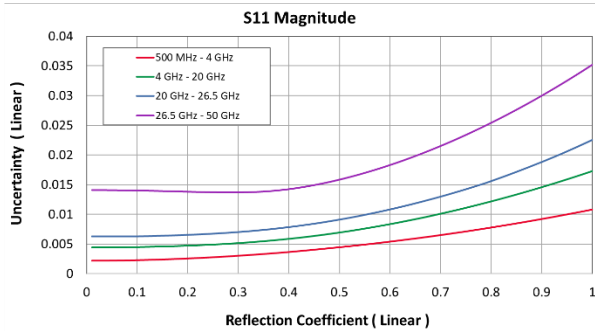

**Table 6. 85056G Calibration kit without Option CDA - Specification (dB)**

	10 MHz to 4 GHz	4 GHz to 20 GHz	20 GHz to 26.5 GHz	26.5 GHz to 50 GHz
<b>Directivity</b>	42	34	30	26
<b>Source Match</b>	40	32	29	25
<b>Load Match</b>	42	34	30	26
<b>Reflection Tracking Magnitude</b>	±0.0005	±0.001	±0.002	±0.014
<b>Transmission Tracking Magnitude</b>	±0.022	±0.025	±0.058	±0.095

**Transmission Uncertainty**

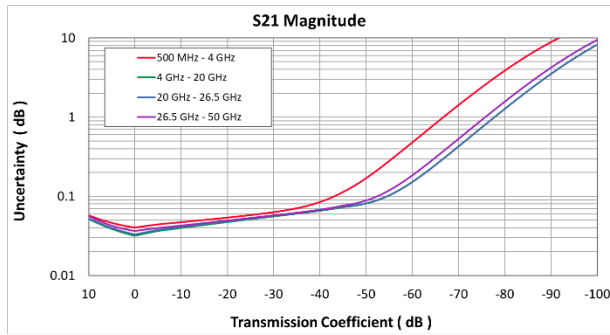

**Reflection Uncertainty**

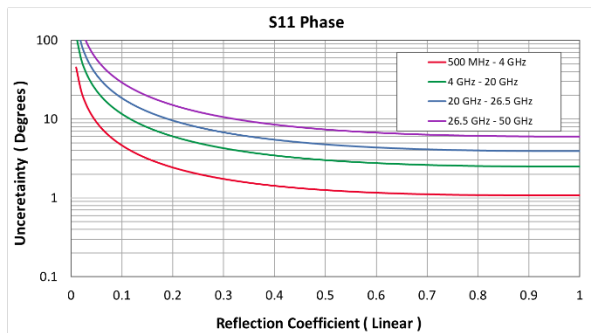
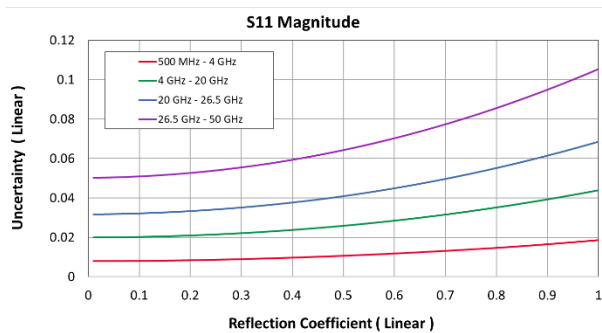

**Table 7. N4693D ECal module with Option 100 - Specification (dB)**

	10 MHz to 45 MHz	45 MHz to 200 MHz	200 MHz to 2 GHz	2 GHz to 10 GHz	10 GHz to 20 GHz	20 GHz to 40 GHz	40 GHz to 50 GHz
<b>Directivity</b>	27	40	46	47	44	38	34
<b>Source Match</b>	25	44	46	42	37	35	32
<b>Load Match</b>	25	44	46	42	37	35	32
<b>Reflection Tracking Magnitude</b>	±0.05	±0.05	±0.03	±0.04	±0.05	±0.06	±0.08
<b>Transmission Tracking Magnitude</b>	±0.05	±0.05	±0.03	±0.04	±0.05	±0.06	±0.08

**Transmission Uncertainty**

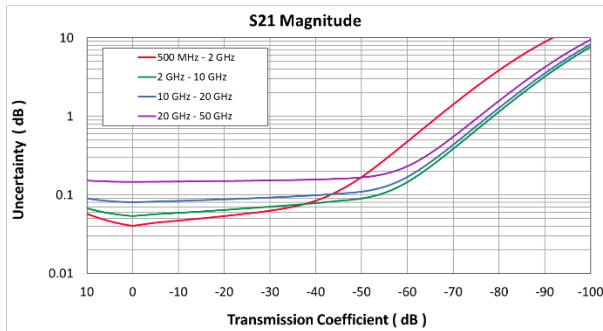

**Reflection Uncertainty**

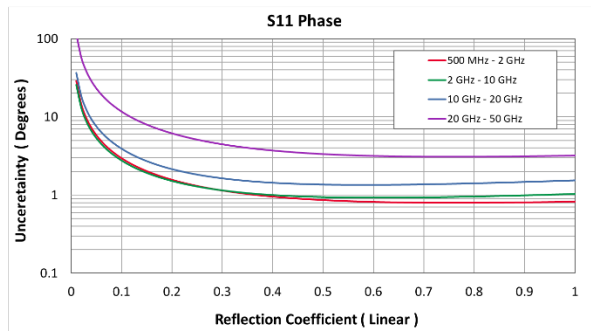
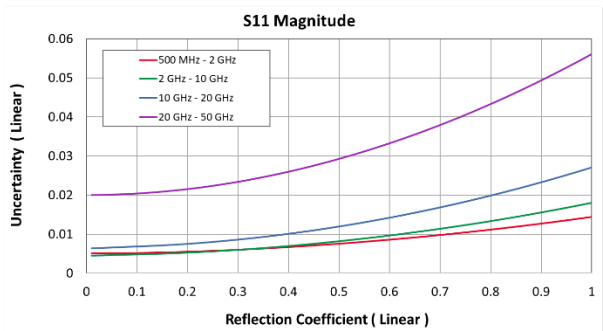

**Table 8. N4693D ECal module with Option 0DC - Specification (dB)**

	10 MHz to 45 MHz	45 MHz to 200 MHz	200 MHz to 2 GHz	2 GHz to 10 GHz	10 GHz to 20 GHz	20 GHz to 40 GHz	40 GHz to 50 GHz
<b>Directivity</b>	40	40	46	47	44	38	34
<b>Source Match</b>	38	36	46	42	37	35	32
<b>Load Match</b>	38	36	46	42	37	35	32
<b>Reflection Tracking Magnitude</b>	±0.05	±0.05	±0.03	±0.04	±0.05	±0.06	±0.08
<b>Transmission Tracking Magnitude</b>	±0.05	±0.05	±0.03	±0.04	±0.05	±0.06	±0.08

**Transmission Uncertainty**

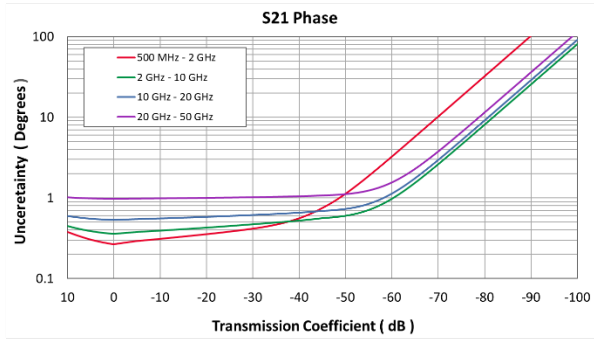
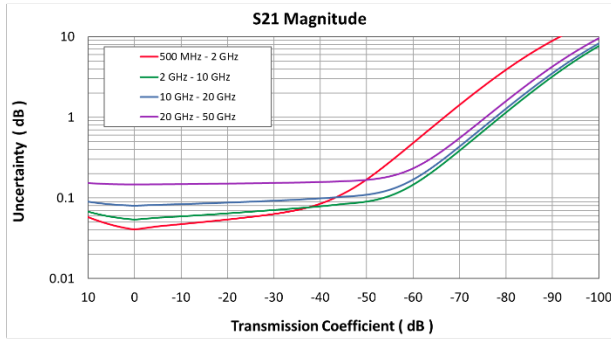

**Reflection Uncertainty**

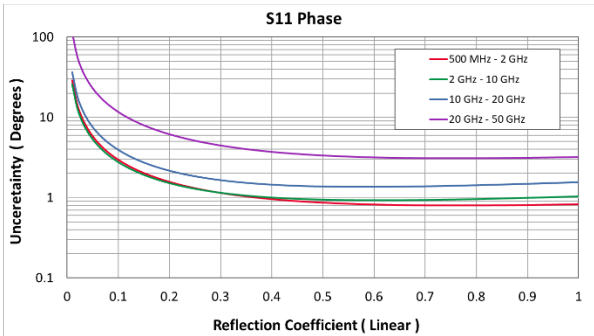
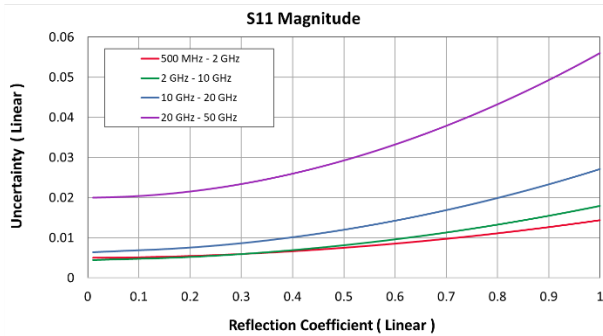

# Uncorrected System Performance

**Table 9. Uncorrected system performance (dB)**

## NA5202A

	Source match	Load match	Directivity	Source match	Load match	Directivity	Transmission tracking	Reflection tracking	Crosstalk
Frequency range	Spec	Spec	Spec	Typical	Typical	Typical	Typical	Typical	Typical
10 MHz to 22 MHz	-10	-12	-19	-15	-18	-23	0.5	0.5	-110
22 MHz to 100 MHz	-17	-17	-22	-24	-27	-27	0.5	0.5	-118
100 MHz to 2 GHz	-16	-16	-27	-22	-20	-33	0.5	0.5	-141
2 GHz to 5 GHz	-12	-12	-26	-17	-17	-32	0.5	0.5	-147
5 GHz to 9 GHz	-11	-11	-22	-16	-15	-29	0.5	0.5	-147
9 GHz to 14 GHz	-10	-10	-18	-15	-14	-22	0.5	0.5	-145
14 GHz to 18 GHz	-9	-9	-18	-14	-13	-22	0.5	0.5	-139
18 GHz to 23 GHz	-7	-7	-18	-11	-10	-22	0.5	0.5	-136
23 GHz to 26.5 GHz	-6	-6	-17	-10	-9	-22	0.5	0.5	-132

## NA5204A/NA5205A

	Source match	Load match	Directivity	Source match	Load match	Directivity	Transmission tracking	Reflection tracking	Crosstalk
Frequency range	Spec	Spec	Spec	Typical	Typical	Typical	Typical	Typical	Typical
10 MHz to 22 MHz	-11	-13	-19	-15	-20	-23	0.5	0.5	-111
22 MHz to 100 MHz	-15	-15	-21	-25	-25	-26	0.5	0.5	-117
100 MHz to 3.2 GHz	-15	-15	-27	-21	-19	-33	0.5	0.5	-142
3.2 GHz to 5 GHz	-15	-15	-23	-21	-19	-28	0.5	0.5	-147
5 GHz to 9 GHz	-12	-12	-20	-17	-16	-25	0.5	0.5	-146
9 GHz to 14 GHz	-12	-12	-17	-17	-16	-20	0.5	0.5	-145
14 GHz to 18 GHz	-11	-11	-14	-17	-16	-18	0.5	0.5	-141
18 GHz to 27 GHz	-9	-8	-14	-14	-12	-18	0.5	0.5	-140
27 GHz to 30 GHz	-7	-6	-14	-12	-11	-18	0.5	0.5	-146
30 GHz to 46 GHz <sup>1</sup>	-7	-6	-13	-10	-10	-17	0.5	0.5	-137
46 GHz to 50 GHz <sup>1</sup>	-5	-6	-13	-9	-9	-17	0.5	0.5	-133

1. NA5204A is up to 43.5 GHz.

**Table 10. Uncorrected system performance, noise mode (dB)**

**NA5202A**

	Source match	Load match	Directivity	Source match	Load match	Directivity	Transmission tracking	Reflection tracking
Frequency range	Spec	Spec	Spec	Typical	Typical	Typical	Typical	Typical
10 MHz to 22 MHz	-6	-6	-20	-8	-8	-23	1	1
22 MHz to 100 MHz	-10	-10	-23	-12	-12	-27	1	1
100 MHz to 2 GHz	-12	-12	-28	-15	-15	-33	1	1
2 GHz to 5 GHz	-12	-12	-26	-15	-15	-32	1	1
5 GHz to 9 GHz	-10	-10	-22	-13	-13	-23	1	1
9 GHz to 14 GHz	-9	-9	-18	-12	-12	-23	1	1
14 GHz to 18 GHz	-7	-7	-17	-10	-10	-22	1	1
18 GHz to 24 GHz	-6	-6	-17	-9	-9	-22	1	1
24 GHz to 26.5 GHz	-5	-5	-17	-9	-9	-22	1	1

**NA5204A/NA5205A**

	Source match	Load match	Directivity	Source match	Load match	Directivity	Transmission tracking	Reflection tracking
Frequency range	Spec	Spec	Spec	Typical	Typical	Typical	Typical	Typical
10 MHz to 22 MHz	-6	-6	-19	-8	-8	-23	1	1
22 MHz to 100 MHz	-10	-10	-21	-12	-12	-26	1	1
100 MHz to 3.2 GHz	-13	-12	-27	-15	-15	-33	1	1
3.2 GHz to 5 GHz	-13	-12	-23	-15	-15	-28	1	1
5 GHz to 9 GHz	-12	-12	-20	-15	-15	-25	1	1
9 GHz to 14 GHz	-11	-11	-17	-14	-14	-20	1	1
14 GHz to 18 GHz	-9	-9	-14	-12	-12	-18	1	1
18 GHz to 27 GHz	-8	-8	-14	-10	-11	-18	1	1
27 GHz to 30 GHz	-7	-7	-14	-10	-10	-18	1	1
30 GHz to 46 GHz <sup>1</sup>	-6	-6	-13	-9	-8	-17	1	1
46 GHz to 50 GHz <sup>1</sup>	-5	-5	-13	-8	-8	-17	1	1

1. NA5204A is up to 43.5 GHz.

# Test Port Output

**Table 11. Frequency resolution, accuracy, stability**

Description	Specification	Typical
Frequency range	NA5202A 10 MHz to 26.5 GHz NA5204A 10 MHz to 43.5 GHz NA5205A 10 MHz to 50 GHz	N/A
Frequency resolution	1 Hz	N/A
Frequency accuracy	±0.15 ppm	N/A
Initial Frequency Accuracy <sup>1</sup>	±0.1 ppm	±0.02 ppm
Frequency stability	N/A	±0.02 ppm, -20° to 70°C <sup>2</sup> ±0.05 ppm (first year) <sup>3</sup>

1. Verified after Factory Frequency Reference adjustment, or after adjustment at a Keysight Service Center.

2. Assumes no variation in time.

3. Assumes no variation in temperature. Stability generally improves over time.

**Table 12. Maximum Output Port Power**

**NA5202A**

Frequency band	Spec (dBm)	Typical (dBm)	Combiner, Typical (dBm)
10 MHz - 32 MHz	7	11	5
32 MHz - 205 MHz	9	13	8
205 MHz - 900 MHz	12	15	11
900 MHz - 4.4 GHz	9	13	8
4.4 GHz - 9 GHz	11	14	9
9 GHz - 14 GHz	9	13	6
14 GHz - 21.25 GHz	6	10	3
21.25 GHz - 24 GHz	3	8	0
24 GHz - 26.5 GHz	-2	4	-4



## NA5204A/NA5205A

Frequency band	Spec (dBm)	Typical (dBm)	Combiner, Typical (dBm)
10 MHz - 32 MHz	8	12	5
32 MHz - 205 MHz	10	14	9
205 MHz - 900 MHz	12	16	10
900 MHz - 4.4 GHz	9	13	6
4.4 GHz - 9 GHz	11	15	7
9 GHz - 14 GHz	8	12	3
14 GHz - 21.25 GHz	5	9	-1
21.25 GHz - 30 GHz	10	15	3
30 GHz - 35 GHz	7	12	0
35 GHz - 42.5 GHz	5	9	-4
42.5 GHz - 46 GHz <sup>1</sup>	3	8	-5
46 GHz - 50 GHz <sup>1</sup>	0	6	-7

1. NA5204A is up to 43.5 GHz.

### Table 13. Power sweep range

## NA5202A

Frequency band	ALC ON Spec (dB)	ALC ON Typical (dB)	ALC OFF Typical (dB)
10 MHz - 32 MHz	32	41	101
32 MHz - 205 MHz	34	43	103
205 MHz - 900 MHz	37	45	105
900 MHz - 4.4 GHz	34	43	103
4.4 GHz - 9 GHz	36	44	104
9 GHz - 14 GHz	34	43	103
14 GHz - 21.25 GHz	31	40	100
21.25 GHz - 24 GHz	28	38	98
24 GHz - 26.5 GHz	23	34	94

## NA5204A/NA5205A

Frequency band	ALC ON Spec (dB)	ALC ON Typical (dB)	ALC OFF Typical (dB)
10 MHz - 32 MHz	33	42	102
32 MHz - 205 MHz	35	44	104
205 MHz - 900 MHz	37	46	106
900 MHz - 4.4 GHz	34	43	103
4.4 GHz - 9 GHz	36	45	105
9 GHz - 14 GHz	33	42	102
14 GHz - 21.25 GHz	30	39	99
21.25 GHz - 30 GHz	35	45	105
30 GHz - 35 GHz	32	42	102
35 GHz - 42.5 GHz	30	39	99
42.5 GHz - 46 GHz <sup>1</sup>	28	38	98
46 GHz - 50 GHz <sup>1</sup>	25	36	96

1. NA5204A is up to 43.5 GHz.

### Table 14. Power level accuracy

#### NA5202A

Frequency band	Spec (dB)	Typical (dB)
10 MHz - 32 MHz	+/-2.5	+/-1.5
32 MHz - 205 MHz	+/-1.5	+/-0.4
205 MHz - 12.5 GHz	+/-1.0	+/-0.4
12.5 GHz - 26.5 GHz	+/-1.5	+/-0.4

#### NA5204A/NA5205A

Frequency band	Spec (dB)	Typical (dB)
10 MHz - 32 MHz	+/-2.5	+/-1.5
32 MHz - 205 MHz	+/-1.5	+/-0.6
205 MHz - 12.5 GHz	+/-1.5	+/-0.4
12.5 GHz - 21.25 GHz	+/-1.5	+/-0.4
21.25 GHz - 42.5 GHz <sup>1</sup>	+/-2.0	+/-0.6
42.5 GHz - 50 GHz <sup>1</sup>	+/-2.5	+/-1.0

1. NA5204A is up to 43.5 GHz.

**Table 15. Power level linearity**

**NA5202A**

<b>ALC ON</b>			
Frequency band	Spec (dB)	Typical (dB)	Typical (dB)
	-25 dBm ≤ P ≤ Max specified power	-25 dBm ≤ P < -15 dBm	-15 dBm ≤ P ≤ Max specified power
10 MHz - 26.5 GHz	+/-1.0	+/- 0.2	+/-0.1

**NA5202A**

<b>ALC OFF</b>			
Frequency band	Typical (dB)	Typical (dB)	Typical (dB)
	-90 dBm ≤ P ≤ -80 dBm	-80 dBm < P < -45 dBm	-45 dBm ≤ P ≤ Max specified power
10 MHz - 205 MHz	--	+/-2.0	+/-0.2
205 MHz - 900 MHz	--	+/-1.25	+/-0.2
900 MHz - 4.4 GHz	+/-1.5	+/-1.0	+/-0.2
4.4 GHz - 23 GHz	+/-1.25	+/-0.5	+/-0.2
23 GHz - 26.5 GHz	+/-1.25	+/-0.5	+/-0.2

**NA5204A/NA5205A**

<b>ALC ON</b>				
Frequency band	Spec (dB)	Spec (dB)	Typical (dB)	Typical (dB)
	-25 dBm ≤ P < -15 dBm	-15 dBm ≤ P ≤ Max specified power	-25 dBm ≤ P < -15 dBm	-15 dBm ≤ P ≤ Max specified power
10 MHz – 32 MHz	+/-1.5	+/-1.0	+/-0.3	+/-0.2
32 MHz - 12.5 GHz	+/-1.5	+/-1.0	+/-0.3	+/-0.1
12.5 GHz - 50 GHz <sup>1</sup>	+/-1.0	+/-1.0	+/-0.3	+/-0.1

1. NA5204A is up to 43.5 GHz.

## NA5204A/NA5205A

### ALC OFF

Frequency band	Typical (dB)	
	-80 dBm ≤ P < -45 dBm	-45 dBm ≤ P ≤ Max specified power
10 MHz - 205 MHz	+/-1.5	+/-1.0
205 MHz - 900 MHz	+/-1.0	+/-0.2
900 MHz - 4.4 GHz	+/-0.6	+/-0.2
4.4 GHz - 26.5 GHz	+/-0.3	+/-0.2
26.5 GHz - 50 GHz <sup>1</sup>	+/-1.0	+/-0.2

1. NA5204A is up to 43.5 GHz.

**Table 16. Harmonics and spurs - typical**

NA5202A

<b>Fundamental frequency</b>	<b>2nd Harmonics @ -5 dBm output (dBc)</b>	<b>2nd Harmonics @ maximum power output (dBc)</b>
10 MHz - 22 MHz	-54	-48
22 MHz - 141 MHz	-55	-49
141 MHz - 480 MHz	-58	-55
480 MHz - 4.4 GHz	-57	-55
4.4 GHz - 13.25 GHz	-69	-63

<b>Fundamental frequency</b>	<b>3rd Harmonics @ -5 dBm output (dBc)</b>	<b>3rd Harmonics @ maximum power output (dBc)</b>
10 MHz - 22 MHz	-57	-55
22 MHz - 141 MHz	-63	-55
141 MHz - 480 MHz	-68	-55
480 MHz - 4.4 GHz	-59	-58
4.4 GHz - 8.85 GHz	-72	-66

<b>Fundamental frequency</b>	<b>Sub Harmonics @ -5 dBm output (dBc)</b>	<b>Sub Harmonics @ maximum power output (dBc)</b>
22 MHz - 45 MHz	-77	-83
45 MHz - 82 MHz	-71	-81
82 MHz - 141 MHz	-76	-81
141 MHz - 480 MHz	-87	-81
480 MHz - 4.4 GHz	-87	-85
4.4 GHz - 26.5 GHz	-71	-69

<b>Fundamental frequency</b>	<b>Non-Harmonic Spurs @ maximum power output (dBc)</b>
10 MHz - 480 MHz	-76
480 MHz - 5.556 GHz	-71
5.556 GHz - 9 GHz	-76
9 GHz - 21.25 GHz	-70
21.25 GHz - 26.5 GHz	-61

## NA5204A/NA5205A

Fundamental frequency	2 <sup>nd</sup> Harmonics @ -5 dBm output (dBc)	2 <sup>nd</sup> Harmonics @ maximum power output (dBc)
10 MHz - 141 MHz	-55	-49
141 MHz - 4.4 GHz	-58	-55
4.4 GHz - 21.25 GHz	-68	-62
21.25 GHz - 25 GHz	-59	-49

Fundamental frequency	3 <sup>rd</sup> Harmonics @ -5 dBm output (dBc)	3 <sup>rd</sup> Harmonics @ maximum power output (dBc)
10 MHz - 22 MHz	-61	-55
22 MHz - 141 MHz	-64	-55
141 MHz - 4.4 GHz	-60	-56
4.4 GHz - 16.7 GHz	-73	-66

Fundamental frequency	Sub Harmonics @ -5 dBm output (dBc)	Sub Harmonics @ maximum power output (dBc)
10 MHz - 82 MHz	-74	-80
82 MHz - 141 MHz	-71	-82
141 MHz - 4.4 GHz	-80	-88
4.4 GHz - 11.8 GHz	-71	-70
11.8 GHz - 21.25 GHz	-70	-75
21.25 GHz - 30 GHz	-75	-75
30 GHz - 42.5 GHz <sup>1</sup>	-71	-71
42.5 GHz - 50 GHz <sup>1</sup>	-59	-59

1. NA5204A is up to 43.5 GHz.

Fundamental frequency	Non-Harmonic Spurs @ maximum power output (dBc)
10 MHz - 480 MHz	-76
480 MHz - 5.556 GHz	-71
5.556 GHz - 9 GHz	-76
9 GHz - 21.25 GHz	-70
21.25 GHz - 26.5 GHz	-61
26.5 GHz - 39.34 GHz	-65
39.34 GHz - 50 GHz <sup>1</sup>	-55

1. NA5204A is up to 43.5 GHz.

**Table 17. Nominal power (Preset Power Level)**

Description	Specification
Nominal power (Preset power level)	-5 dBm

**Table 18. Power resolution, maximum/minimum settable power**

Description	Specification	Typical
Settable resolution	--	0.01 dB
Maximum settable power	--	+30 dBm
Minimum settable power	--	-100 dBm

**Table 19. Phase noise with Option UNY (dBc/Hz)<sup>1</sup>**

Frequency	Offset frequency					
	100 Hz	1 kHz	10 kHz	100 kHz	1 MHz	10 MHz
1 GHz	-111	-131	-141	-148	-154	-154
5 GHz	-99	-122	-132	-137	-146	-146
10 GHz	-93	-114	-124	-131	-140	-140
20 GHz	-86	-108	-119	-124	-134	-134
26.5 GHz	-84	-108	-118	-123	-132	-132

1. Typical data

**Table 20. Phase noise without Option UNY (dBc/Hz)<sup>1</sup>**

Frequency	Offset frequency					
	100 Hz	1 kHz	10 kHz	100 kHz	1 MHz	10 MHz
1 GHz	-90	-114	-131	-141	-150	-154
5 GHz	-77	-101	-117	-127	-137	-145
10 GHz	-72	-95	-111	-121	-131	-137
20 GHz	-65	-89	-105	-115	-125	-132
26.5 GHz	-63	-87	-102	-113	-122	-130

1. Typical data

# Test Port Input

**Table 21. Test port noise floor<sup>1</sup>**

**NA5202A**

Frequency band	Low gain mode		High gain mode	
	Spec (dBm)	Typical (dBm)	Spec (dBm)	Typical (dBm)
10 MHz - 45 MHz	-70	-75	-80	-85
45 MHz - 141 MHz	-88	-93	-99	-106
141 MHz - 900 MHz	-100	-105	-116	-120
900 MHz - 11.1 GHz	-112	-117	-130	-133
11.1 GHz - 12.5 GHz	-111	-116	-130	-133
12.5 GHz - 15.8 GHz	-111	-116	-128	-132
15.8 GHz - 21.25 GHz	-111	-116	-129	-133
21.25 GHz - 26.5 GHz	-113	-118	-129	-133

**NA5204A/NA5205A**

Frequency band	Low gain mode		High gain mode	
	Spec (dBm)	Typical (dBm)	Spec (dBm)	Typical (dBm)
10 MHz - 45 MHz	-70	-74	-81	-85
45 MHz - 141 MHz	-87	-92	-100	-105
141 MHz - 900 MHz	-100	-104	-116	-120
900 MHz - 11.1 GHz	-112	-116	-129	-133
11.1 GHz - 12.5 GHz	-111	-115	-127	-132
12.5 GHz - 15.8 GHz	-111	-115	-127	-132
15.8 GHz - 21.25 GHz	-111	-115	-127	-132
21.25 GHz - 35 GHz	-112	-117	-127	-132
35 GHz - 50 GHz <sup>2</sup>	-109	-114	-125	-130

1. At 10 Hz IFBW
2. NA5204A is up to 43.5 GHz.

**Table 22. Receiver compression at test port**

**NA5202A**

Description	Specification			Typical	
	Input power at test port (dBm)	Magnitude (dB)	Phase (°)	Magnitude (dB)	Phase (°)
500 MHz to 23 GHz	12	0.15	1.5	0.07	0.2
23 GHz to 26.5 GHz	12	0.2	1.5	0.1	0.2

0.1 dB compression (typical)	
Description	Input power at test port (dBm)
500 MHz to 26.5 GHz	13



## NA5204A/5A

Description	Specification			Typical	
	Input power at test port (dBm)	Magnitude (dB)	Phase (°)	Magnitude (dB)	Phase (°)
500 MHz to 26.5 GHz	12	0.17	1.5	0.07	0.3
26.5 GHz to 50 GHz <sup>1</sup>	10	0.22	3	0.1	1.5

1. NA5204A is up to 43.5 GHz.

### 0.1 dB compression (typical)

Description	Input power at test port (dBm)
500 MHz to 26.5 GHz	14
26.5 GHz to 50 GHz <sup>1</sup>	9

1. NA5204A is up to 43.5 GHz.

**Table 23. Trace noise magnitude (dB rms) <sup>1</sup>**

## NA5202A

Frequency band	Spec		Typical		
	IFBW = 1 kHz	IFBW = 1 kHz	IFBW = 100 kHz	IFBW = 600 kHz	IFBW = 50 MHz <sup>2</sup>
10 MHz to 900 MHz	0.025	0.018	0.17	0.39	0.11
900 MHz to 23 GHz	0.0013	0.0005	0.0022	0.0051	0.05
23 GHz to 26.5 GHz	0.001	0.0005	0.0022	0.0048	0.05

1. Low gain mode -5 dBm

2. IFBW=50 MHz starts at 205 MHz.

## NA5204A/NA5205A

Frequency band	Spec		Typical		
	IFBW = 1 kHz	IFBW = 1 kHz	IFBW = 100 kHz	IFBW = 600 kHz	IFBW = 50 MHz <sup>2</sup>
10 MHz to 67 MHz	0.1	0.043	0.42	1.01	N/A
67 MHz to 141 MHz	0.007	0.0032	0.03	0.07	N/A
141 MHz to 1.14 GHz	0.003	0.0013	0.013	0.03	0.22
1.14 GHz to 21.25 GHz	0.002	0.0006	0.0025	0.006	0.061
21.25 GHz to 50 GHz <sup>2</sup>	0.001	0.0005	0.0025	0.006	0.057

1. Low gain mode at -5 dBm

2. IFBW=50 MHz starts at 205 MHz

3. NA5204A is up to 43.5 GHz

**Table 24. Trace noise phase (degree rms) <sup>1</sup>**

**NA5202A**

Frequency band	Spec		Typical		
	IFBW = 1 kHz	IFBW = 1 kHz	IFBW =100 kHz	IFBW = 600 kHz	IFBW = 50 MHz
10 MHz to 205 MHz	0.18	0.12	1.16	2.7	N/A
205 MHz to 900 MHz	0.005	0.0031	0.03	0.072	0.74
900 MHz to 7.91 GHz	0.003	0.0018	0.015	0.035	0.34
7.91 GHz to 14 GHz	0.004	0.002	0.015	0.034	0.35
14 GHz to 18 GHz	0.004	0.002	0.014	0.032	0.33
18 GHz to 26.5 GHz	0.0068	0.0032	0.016	0.035	0.37

1. Low gain mode at -5 dBm

**NA5204A/NA5205A**

Frequency band	Spec		Typical		
	IFBW = 1 kHz	IFBW = 1 kHz	IFBW =100 kHz	IFBW = 600 kHz	IFBW = 50 MHz <sup>2</sup>
10 MHz to 67 MHz	0.45	0.3	2.9	6.7	N/A
67 MHz to 141 MHz	0.03	0.021	0.21	0.48	N/A
141 MHz to 814 MHz	0.013	0.009	0.083	0.2	1.43
814 MHz to 7.91 GHz	0.004	0.0019	0.016	0.04	0.4
7.91 GHz to 15.8 GHz	0.005	0.003	0.018	0.041	0.43
15.8 GHz to 25.1GHz	0.007	0.003	0.018	0.041	0.43
25.1 GHz to 35 GHz	0.012	0.006	0.019	0.042	0.43
35 GHz to 50 GHz <sup>2</sup>	0.017	0.006	0.019	0.042	0.43

1. Low gain mode at -5 dBm
2. IFBW=50 MHz starts at 205 MHz
3. NA5204A is up to 43.5 GHz

**Table 25. Stability**<sup>1</sup>**NA5202A**

Frequency band	Magnitude (dB)		Phase (degree rms)	
	Low gain mode	High gain mode	Low gain mode	High gain mode
10 MHz - 100 MHz	0.02	0.04	0.33	0.33
100 MHz - 480 MHz	0.02	0.04	0.06	0.08
480 MHz - 1.5 GHz	0.02	0.04	0.07	0.08
1.5 GHz - 7 GHz	0.03	0.04	0.15	0.1
7 GHz - 11.1 GHz	0.03	0.05	0.25	0.15
11.1 GHz - 15.8 GHz	0.04	0.06	0.36	0.23
15.8 GHz - 18 GHz	0.05	0.08	0.45	0.28
18 GHz - 22.2 GHz	0.06	0.08	0.59	0.43
22.2 GHz - 24 GHz	0.06	0.08	0.62	0.5
24 GHz - 26.5 GHz	0.06	0.08	0.71	0.5

**NA5204A/NA5205A**

Frequency band	Magnitude (dB)		Phase (degree rms)	
	Low gain mode	High gain mode	Low gain mode	High gain mode
10 MHz - 297 MHz	0.03	0.04	0.33	0.33
297 MHz - 5 GHz	0.02	0.04	0.02	0.08
5 GHz - 9 GHz	0.02	0.04	0.05	0.08
9 GHz - 15.8 GHz	0.03	0.04	0.08	0.1
15.8 GHz - 25.1 GHz	0.03	0.06	0.16	0.23
25.1 GHz - 29 GHz	0.04	0.08	0.2	0.28
29 GHz - 35 GHz	0.04	0.08	0.25	0.43
35 GHz - 42.5 GHz	0.05	0.08	0.28	0.5
42.5 GHz - 50 GHz <sup>2</sup>	0.06	0.08	0.37	0.5

1. Stability is defined as a ratio measurement made at the test port.

2. NA5204A is up to 43.5 GHz.

**Table 26. Damage input level at test ports**

Test set option	Damage input level
239, 439, and 479	+20 dBm or $\pm 7$ VDC
451, 471	+30 dBm or $\pm 7$ VDC
231, 431	+30 dBm or $\pm 20$ VDC
241, 441, 249, 449, 481 and 489	+30 dBm or $\pm 40$ VDC

**Table 27. Displayed averaged noise Level (DANL)<sup>1</sup>**

**NA5202A**

Frequency band	Low gain mode		High gain mode	
	Spec (dBm)	Typical (dBm)	Spec (dBm)	Typical (dBm)
10 MHz - 141 MHz	-92	-95	-103	-106
141 MHz - 1.14 GHz	-114	-117	-130	-133
1.14 GHz - 14 GHz	-126	-130	-145	-148
14 GHz - 26.5 GHz	-126	-130	-144	-148

**NA5204A/NA5205A**

Frequency band	Low gain mode		High gain mode	
	Spec (dBm)	Typical (dBm)	Spec (dBm)	Typical (dBm)
10 MHz - 220 MHz	-95	-98	-106	-109
220 MHz - 814 MHz	-119	-122	-135	-138
814 MHz - 8.819 GHz	-127	-130	-145	-147
8.819 GHz - 33 GHz	-126	-129	-144	-147
33 GHz - 50 GHz <sup>2</sup>	-124	-128	-140	-144

1. Tested with 10 kHz RBW, test port terminated, average detector, averaging type = Log, random LO OFF. The specification is normalized to 1.2 Hz minimum available RBW.
2. NA5204A is up to 43.5 GHz.

**Table 28. Third Order Intermodulation distortion (TOI)<sup>1</sup>**

**NA5202A**

Frequency band	Low gain - TOI		Low gain - Distortion	
	Characteristics (dBm)	Typical (dBm)	Characteristics (dBc)	Typical (dBc)
500 MHz - 15.8 GHz	21	25	-62	-70
15.8 GHz - 21.25 GHz	20	24	-60	-68
21.25 GHz - 26.5 GHz	19	23	-58	-66

1. Tested with -10 dBm input at test port.

**NA5202A**

Frequency band	High gain - TOI		High gain - Distortion	
	Characteristics (dBm)	Typical (dBm)	Characteristics (dBc)	Typical (dBc)
500 MHz - 4.2 GHz	-4	-1	-42	-48
4.2 GHz - 15.8 GHz	-3	0	-44	-50
15.8 GHz - 26.5 GHz	-4	-1	-42	-48

1. Tested with -25 dBm input at test port.

## NA5204A/NA5205A

Frequency band	Low gain - TOI		Low gain - Distortion	
	Characteristics (dBm)	Typical (dBm)	Characteristics (dBc)	Typical (dBc)
500 MHz - 18 GHz	18	24	-56	-68
18 GHz - 28 GHz	17	23	-54	-66
28 GHz - 39.34 GHz	13	20	-46	-60
39.34 GHz - 47.2 GHz <sup>2</sup>	10	17	-40	-54
47.2 GHz - 50 GHz <sup>2</sup>	10	15	-40	-50

1. Tested with -10 dBm input at test port.
2. NA5204A is up to 43.5 GHz.

## NA5204A/NA5205A

Frequency Band	High gain - TOI		High gain - Distortion	
	Characteristics (dBm)	Typical (dBm)	Characteristics (dBc)	Typical (dBc)
500 MHz-4.2 GHz	-4	-1	-42	-48
4.2 GHz-28 GHz	-3	0	-44	-50
28 GHz-33 GHz	-6	-2	-38	-46
33 GHz-50 GHz <sup>2</sup>	-8	-4	-34	-42

1. Tested with -25 dBm input at test port.
2. NA5204A is up to 43.5 GHz.

**Table 29. SA detector accuracy – specification**

**NA5202A**

**At Frequency-band crossing**

Frequency band	Narrow IF filter (dB)	Wide IF filter (dB)
10 MHz to 297 MHz	±0.70	±0.25
297 MHz to 26.5 GHz	±0.20	±0.20

**NA5202A**

**Without Frequency-band crossing**

Frequency band	Narrow IF filter (dB)	Wide IF filter (dB)
10 MHz to 297 MHz	±0.20	±0.20
297 MHz to 9 GHz	±0.13	±0.15
9 GHz to 26.5 GHz	±0.13	±0.15

**NA5204A/NA5205A**

**At Frequency-band crossing**

Frequency band	Narrow IF filter (dB)	Wide IF filter (dB)
20 MHz to 297 MHz	±0.70	±0.35
297 MHz to 26.5 GHz	±0.25	±0.25
26.5 GHz to 50 GHz <sup>1</sup>	±0.25	±0.25

1. NA5204A is up to 43.5 GHz.

**NA5204A/NA5205A**

**Without Frequency-band crossing**

Frequency band	Narrow IF filter (dB)	Wide IF filter (dB)
10 MHz to 297 MHz	±0.17	±0.20
297 MHz to 9 GHz	±0.15	±0.17
9 GHz to 26.5 GHz	±0.15	±0.17
26.5 GHz to 50 GHz <sup>1</sup>	±0.15	±0.17

1. NA5204A is up to 43.5 GHz.

# Noise Receiver Input

**Table 30. Receiver noise figure (dB) at 4 MHz IFBW, 30 dB Gain**

## NA5202A

Description	Specification	Typical
10 MHz to 22 MHz	19	13
22 MHz to 480 MHz	14	10
480 MHz to 2 GHz	15	12
2 GHz to 6 GHz	17	13
6 GHz to 9 GHz	18	14
9 GHz to 18 GHz	13	11
18 GHz to 26.5 GHz	14	12

## NA5204A/NA5205A

Description	Specification	Typical
10 MHz to 22 MHz	21	15
22 MHz to 100 MHz	14	10
100 MHz to 3.2 GHz	18	14
3.2 GHz to 9 GHz	20	16
9 GHz to 24 GHz	15	12
24 GHz to 30 GHz	16	14
30 GHz to 46 GHz <sup>1</sup>	20	17
46 GHz to 50 GHz <sup>1</sup>	21	17

1. NA5204A is up to 43.5 GHz.

**Table 31. Noise figure trace noise (dB rms) at 4 MHz BW<sup>1</sup>**

Description	Specification	Typical
10 MHz to 26.5 GHz (NA5202A)	0.15	0.1
10 MHz to 43.5/50 GHz (NA5204A/5A) <sup>2</sup>	0.15	0.11

1. The trace noise data is valid for all four gain modes.  
 2. NA5204A is up to 43.5 GHz.

**Table 32. Noise receiver linearity (dB) at 4 MHz BW <sup>1</sup>**

**NA5202A**

Power range				Specification
<b>30 dB gain, Reference to -60 dBm</b>	<b>15 dB Gain, Reference to -50 dBm</b>	<b>0 dB Gain, Reference to -20 dBm</b>	<b>-15 dB Gain, Reference to -20 dBm</b>	
-45 dBm to -85 dBm	-31 dBm to -70 dBm	-19 dBm to -40 dBm	-5 dBm to -30 dBm	±0.05 dB

**NA5204A/NA5205A**

Power range				Specification
<b>30 dB gain, Reference to -60 dBm</b>	<b>15 dB Gain, Reference to -50 dBm</b>	<b>0 dB Gain, Reference to -20 dBm</b>	<b>-15 dB Gain, Reference to -20 dBm</b>	
-45 dBm to -85 dBm	-31 dBm to -70 dBm	-19 dBm to -40 dBm	-5 dBm to -30 dBm	±0.05 dB

1. Noise receiver linearity verification is at 99.6 MHz.



### Table 33. Noise receiver input range – specification

#### NA5202A

Description	Max DUT NF + Gain (dB) <sup>1</sup>				Max Input Power (dBm) for < 0.1 dB Compression <sup>2</sup>			
	30 dB Gain	15 dB Gain	0 dB Gain	-15 dB Gain	30 dB Gain	15 dB Gain	0 dB Gain	-15 dB Gain
500 MHz to 2.68 GHz	47	61	73	88	-41	-27	-15	0
2.68 GHz to 5.56 GHz	49	63	75	88	-39	-25	-13	0
5.56 GHz to 7 GHz	50	64	76	88	-38	-24	-12	0
7 GHz to 8.82 GHz	52	65	77	88	-36	-23	-11	0
8.82 GHz to 17.629 GHz	48	61	74	88	-40	-27	-14	0
17.629 GHz to 26.5 GHz	48	61	74	83	-40	-27	-14	-5

- Limited by 0.1 dB receiver compression. Applies to devices with bandwidth < 400 MHz. For devices with higher than bandwidths, calculate the DUT output noise power as  $-174 \text{ dBm} + 10 \cdot \log_{10}(B) + \text{Gain (dB)} + \text{NF (dB)}$ , where B is the bandwidth of the DUT in Hz, and use the Max Input Power specification.
- Derived from ensuring < 0.25 dB compression with a CW signal 5 dB higher than the stated max input power value for 0.1 dB compression. Referenced to test port 2.

#### NA5204A/NA5205A

Description	Max DUT NF + Gain (dB) <sup>1</sup>				Max Input Power (dBm) for < 0.1 dB Compression <sup>2</sup>			
	30 dB Gain	15 dB Gain	0 dB Gain	-15 dB Gain	30 dB Gain	15 dB Gain	0 dB Gain	-15 dB Gain
500 MHz to 2.68 GHz	46	60	73	88	-42	-28	-15	0
2.68 GHz to 5.56 GHz	48	62	75	88	-40	-26	-13	0
5.56 GHz to 7 GHz	49	63	76	88	-39	-25	-12	0
7 GHz to 8.82 GHz	51	64	77	88	-37	-24	-11	0
8.82 GHz to 17.629 GHz	48	60	74	88	-40	-28	-14	0
17.629 GHz to 21.25 GHz	48	60	74	83	-40	-28	-14	-5
21.25 GHz to 33 GHz	48	60	73	88	-40	-28	-15	0
33 GHz to 35 GHz	48	60	73	88	-40	-28	-15	0
35 GHz to 39.34 GHz	43	57	69	83	-45	-31	-19	-5
39.34 GHz to 50 GHz <sup>3</sup>	43	58	70	83	-45	-30	-18	-5

- Limited by 0.1 dB receiver compression. Applies to devices with bandwidth < 400 MHz. For devices with higher than bandwidths, calculate the DUT output noise power as  $-174 \text{ dBm} + 10 \cdot \log_{10}(B) + \text{Gain (dB)} + \text{NF (dB)}$ , where B is the bandwidth of the DUT in Hz, and use the Max Input Power specification.
- Derived from ensuring < 0.25 dB compression with a CW signal 5 dB higher than the stated max input power value for 0.1 dB compression. Referenced to test port 2.
- NA5204A is up to 43.5 GHz.

# General Information

## Table 34. Miscellaneous information

Description	Supplemental Information
System IF Bandwidth Range	1 Hz to 15 MHz, nominal. 20 MHz and 100 MHz nominal (Option W1F)
CPU	For the latest information on CPUs and associated hard drives, visit: <a href="http://PNA Hard Drives and CPUs (keysight.com)">PNA Hard Drives and CPUs (keysight.com)</a>
LXI	CPU version 10.0  LXI 1.5 Extended functions: HiSLIP; VSI-11 Discovery and Identification
Maximum number of points	100003

## Table 35. Front panel information, all options

Description	Typical performance
<b>RF Connectors</b>	
Test ports	NA5202A 3.5 mm (male), 50 ohm (nominal), 0.002 in. Center Pin Recession (characteristic) NA5204A/5A 2.4 mm (male), 50 ohm (nominal), 0.002 in. Center Pin Recession (characteristic)
Jumpers	NA5202A 3.5 mm (female) connectors with SMA (male) jumper cables NA5204A/5A 2.4 mm (female) connectors with 2.4 mm (male) jumper cables
<b>USB 2.0 ports - Primary (4 ports)</b>	
Standard	Compatible with USB 2.0
Connector	USB Type-A female
<b>Display</b>	
Size	31 cm (12.1 in) diagonal color active-matrix LCD; 1280 (horizontal) X 800 (vertical) resolution
Refresh rate	Vertical 60 Hz; Horizontal 49.31 kHz
Pixels	Any of the following would cause a display to be considered faulty: A complete row or column consists of "stuck" or "dark" pixels. More than six "stuck on" pixels (but not more than three green) or more than 0.002% of the total pixels are within the LCD specifications. More than twelve "dark" pixels (but no more than seven of the same color) or more than 0.004% of the total pixels are within the LCD specifications. Two or more consecutive "stuck on" pixels or three or more consecutive "dark" pixel (but no more than one set of two consecutive dark pixels). "Stuck on" pixels or more than two "dark" pixels less than 6.5 mm apart (excluding consecutive pixels).
<b>Display range</b>	
Magnitude	±2500 dB (at 500 dB/div), max
Phase	±2500° (at 500 degrees/div), max
Polar	10 pUnits, min 10,000 Units, max
<b>Display resolution</b>	
Magnitude	0.001 dB/div, min
Phase	0.01°/div, min
<b>Marker resolution</b>	
Magnitude	0.001 dB, min
Phase	0.01°, min
Polar	10 pUnit, min

## Table 36. Rear Panel Information, All Options

Description	Typical performance
<b>External reference In</b>	
Connector	BNC, female
Input frequency	10 MHz $\pm$ 0.3 ppm, 100 MHz $\pm$ 0.3 ppm
Input level	10 MHz: -15 dBm to +20 dBm 100 MHz: -10 dBm to +20 dBm
Input impedance	50 $\Omega$ , nominal
<b>External reference Out</b>	
Connector	BNC, female
Output frequency	10 MHz $\pm$ 0.15 ppm, 100 MHz $\pm$ 0.15 ppm
Signal type	Sine wave
Output level	+10 dBm $\pm$ 4 dB into 50 $\Omega$
Output impedance	50 $\Omega$ , nominal
Harmonics	<-40 dBc, typical
<b>2.4 GHz Clock In</b>	
Connector	SMA, female
Input frequency	2.4 GHz $\pm$ 0.3 ppm
Input level	-15 dBm to +20 dBm
Input impedance	50 $\Omega$ , nominal
<b>2.4 GHz Clock Out</b>	
Connector	SMA, female
Signal type	Sine wave
Output frequency	2.4 GHz $\pm$ 0.15 ppm
Output level	+5 dBm $\pm$ 2 dB into 50 $\Omega$
Output impedance	50 $\Omega$ , nominal
<b>External IF Inputs (Option D1F)</b>	
Function	Allows use of external IF signals from remote mixers, bypassing the PNA's first converters
Connectors	3.5 mm (female); A, B, C, D, R1, R2, R3, R4 (4-port); A, B, R1, R2 (2-port)
Input impedance	50 $\Omega$
RF damage level	+23 dBm
DC damage level	1 VDC
0.1 dB Compression point (Normal IF path)	-1.02 dBm at 7.365 MHz
<b>External IF Outputs (Option D1F)</b>	
Function	Allows use of wideband IF signals from internal mixers
Connectors	SMA (female); A, B, C, D, R1, R2, R3, R4 (4-port); A, B, R1, R2 (2-port)
Bandwidth	Up to 5 GHz
<b>Pulse I/O connector</b>	
Connector type	15-pin mini D-sub (for pin assignment information, refer to the <a href="#">PNA online help</a> )

Description	Typical performance	
<b>Pulse inputs (IF gates)</b>		
Function	Internal receiver gates used for point-in-pulse and pulse-profile measurements	
Input impedance	> 10 kohms	
Source modulators	20 ns minimum pulse width	
Rf damage level	+23 dBm	
Dc damage level	5.5 VDC	
Drive voltage	0 V (Off), +3.3 V (On), nominal	
<b>Pulse modulator On/Off ratio</b>		
	<b>NA5202A</b>	<b>NA5204A/5A</b>
10 MHz to 4.4 GHz	-77 dB	-77 dB
4.4 GHz to 21.25 GHz	-99 dB	-100 dB
21.25 GHz to 26.5 GHz	-99 dB	-58 dB
26.5 GHz to 50 GHz <sup>1</sup>	N/A	-58 dB
<b>External test set driver</b>		
Function	Used for driving remote mixers	
Connections	3.5 mm (female)	
LO output frequency range	0.01 GHz to 26.5 GHz	
<b>Rear panel LO power</b>		
<b>Frequency band</b>	<b>Upper limit, typical (dBm)</b>	<b>Lower limit, typical (dBm)</b>
10 MHz -2.681 GHz	3.5	-3.5
2.681 GHz - 15.8 GHz	2.5	-3
15.8 GHz - 29 GHz	4	-4.5
29 GHz - 39.34 GHz	3	-3
39.34 GHz - 50 GHz	3.5	-3.5
<b>Bias tee inputs</b>		
Connectors	BNC(f) for ports 1, 2, 3 and 4	
Fuse	500 mA, bi-pin style	
Maximum bias current <sup>2</sup>	±200 mA	
Maximum bias voltage <sup>2</sup>	±5 VDC	20 MHz to 26.5 GHz/ 43.5 GHz/ 50 GHz (NA5202/4/5A)
	±10 VDC	60 MHz to 26.5 GHz/ 43.5 GHz/ 50 GHz (NA5202/4/5A)
	±15 VDC	100 MHz to 26.5 GHz/ 43.5 GHz/ 50 GHz (NA5202/4/5A)
	±20 VDC	200 MHz to 26.5 GHz/ 43.5 GHz/ 50 GHz (NA5202/4/5A)
	±25 VDC	300 MHz to 26.5 GHz/ 43.5 GHz/ 50 GHz (NA5202/4/5A)
	±30 VDC	400 MHz to 26.5 GHz/ 43.5 GHz/ 50 GHz (NA5202/4/5A)
	±35 VDC	700 MHz to 26.5 GHz/ 43.5 GHz/ 50 GHz (NA5202/4/5A)
	±40 VDC	700 MHz to 26.5 GHz/ 43.5 GHz/ 50 GHz (NA5202/4/5A)

1. NA5204A is up to 43.5 GHz
2. with no degradation in RF specifications

Other rear panel interface	
Trigger inputs/outputs	SMB(f), TTL/CMOS compatible
Test set IO	25-pin D-Sub connector, available for external test set control
Power IO	9-pin D-Sub, female; analog and digital IO
Handler IO	37-pin D-Sub connector; all input/output signals are default set to negative logic; can be reset to positive logic via GPIB command
GPIB	Two ports - dedicated controller and dedicated talker/listener. 24-pin D-sub (Type D-24), female; compatible with IEEE-488
28 V	28 volts switched for noise source
CPU version	10.0
USB-A ports	Four SuperSpeed USB ports (900 mA each) and one USB device port. There are also four USB-A ports (500 mA each) on the front panel. The total current limit for all rear panel USB-A ports is 3.6 amps. The total current limit for all front panel USB-A ports is 2 amps.
USB-C (Host)	Two USB-C connectors with support for USB-3.1. Thunderbolt3, and Display Port. max Power Delivery of 15W at 5V or 36W at 15V each
LAN	1G and 10G ports; 10GBASE-T, Ethernet, 8-pin configuration; auto selects between the data rates. Works with Cat6/Cat7 cable.
DisplayPort	Standard DisplayPort connector for connection to external displays
Line power	
Frequency, Voltage	50/60/400 Hz for 100/120 VAC 50/60 Hz for 220/240 VAC
	Power supply is auto switching
Max	900 W

## Table 37. Analyzer dimensions and weight

All models are shipped with bottom feet, handles and front and rear hardware.

### Cabinet dimensions

Height	Metric (mm)	Imperial (inches)
Without bottom feet: EIA RU <sup>1</sup> = 6	267	10.5
With bottom feet	282	11.1
Width	Metric (mm)	Imperial (inches)
Without handles or rack-mount flanges	426	16.8
With handles, without rack-mount flanges	573	22.6
With handles and rack-mount flanges	TBD	TBD
Depth	Metric (mm)	Imperial (inches)
Without front and rear panel hardware	591	23.3
With front and rear panel hardware, handles	705	27.75
Weight (nominal)	Net	Shipping
NA5202A 2-port models	99.2 lbs, 45.0 kg	129.2 lbs, 58.6 kg
NA5202A 4-port models	118.4 lbs, 53.7 kg	148.4 lbs, 67.3 kg
NA5204A/5A 2-port models	103.0 lbs, 46.7 kg	133.0 lbs, 60.3 kg
NA5204A/5A 4-port models	123.2 lbs, 55.0 kg	153.2 lbs, 68.6 kg

<sup>1</sup> Electronics Industry Association rack units. 1 RU = 1.75 in.

**Table 38. Environmental and physical specifications**

Description	
Description	Samples of this product have been type tested in accordance with the Keysight Environmental Test Manual and verified to be robust against the environmental stresses of Storage, Transportation and End-use; those stresses include, but are not limited to, temperature, humidity, shock, vibration, altitude, and power line conditions. Test Methods are aligned with IEC 60068-2 and levels are similar to MIL-PRF-28800F Class 3.
Temperature	Operating                      0 to 40 °C ambient
	Storage                            -40 to 70 °C
Relative humidity	Type tested, 0 to 95 % at 40 °C (non-condensing)
Altitude	Operating/non-operating    Up to 4,572 meters (15,000 feet)
Warm-up time	90 minutes

## Regulatory and environmental information

For Regulatory and Environmental information, refer to the PNA Series Installation and Quick Start Guide, located online at <http://literature.cdn.keysight.com/litweb/pdf/E8356-90001.pdf>.

Currently, there is no NA520xA certification available for CE and South Korean Certification (KC) mark for the identifier code: Kst-WN24938.

## PNA-X Test Set Configuration Details

This section describes test set options in more detail and provides block diagrams. The block diagrams include additional hardware options that are not part of the test set options, such as pulse modulators, receiver attenuators, a noise receiver on Port 1, a combiner on Port 2, and IF access. Refer to the section “Hardware options” for a complete list. Also refer to the product data sheet and technical overview for more information.

### 2-port test set options

Two-port test set options come with two sources. Setting the two sources to different frequencies requires Option 2SS and one of these software licenses: S93080/029/082/083/084/086/087/089/090x/093/094B.

If the bias tees are not included, the maximum power rating on the test port couplers is +43 dBm. If the bias tees are included, the maximum power rating on the test port couplers is limited to +30 dBm. In either case, additional attenuators or isolators are typically required to protect other components inside the instrument.

## 2-ports, source attenuators, with configurable test set (Option 231)

This 2-port test set option comes with four front-panel access loops, a source attenuator, and a switched-gain test receiver with pre-selection filters for each port. The loops provide access to the signal path (a) between the source output and the reference receiver, (b) between the source output and the directional coupler thru arm, (c) between the coupled arm of the directional coupler and the test port receiver, and (d) to the mechanical switch of the source output as a switchable source loop. It also comes with eight pulse generators and optional receiver attenuators and pulse modulators.

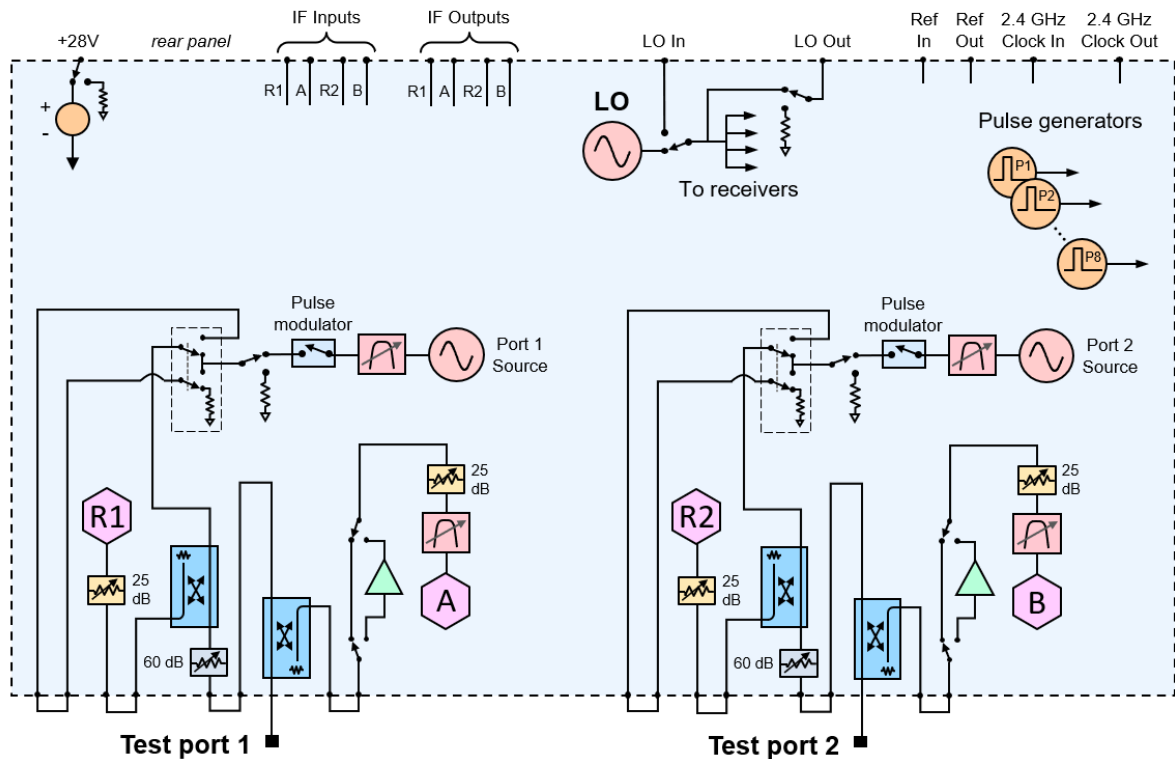

## 2-ports, source attenuators, low-noise receivers with configurable test set (Option 239)

This test set option includes the same hardware as Option 231: four front-panel access loops, a source attenuator, and a switched-gain test receiver with pre-selection filters for each port, and also comes with eight pulse generators and optional receiver attenuators and pulse modulators. In addition, this option provides a low-noise receiver on port 2 and a noise tuner on port 1. Option NR1 adds a low-noise receiver to port 1 and a built-in noise tuner to port 2 for reverse noise figure measurements.

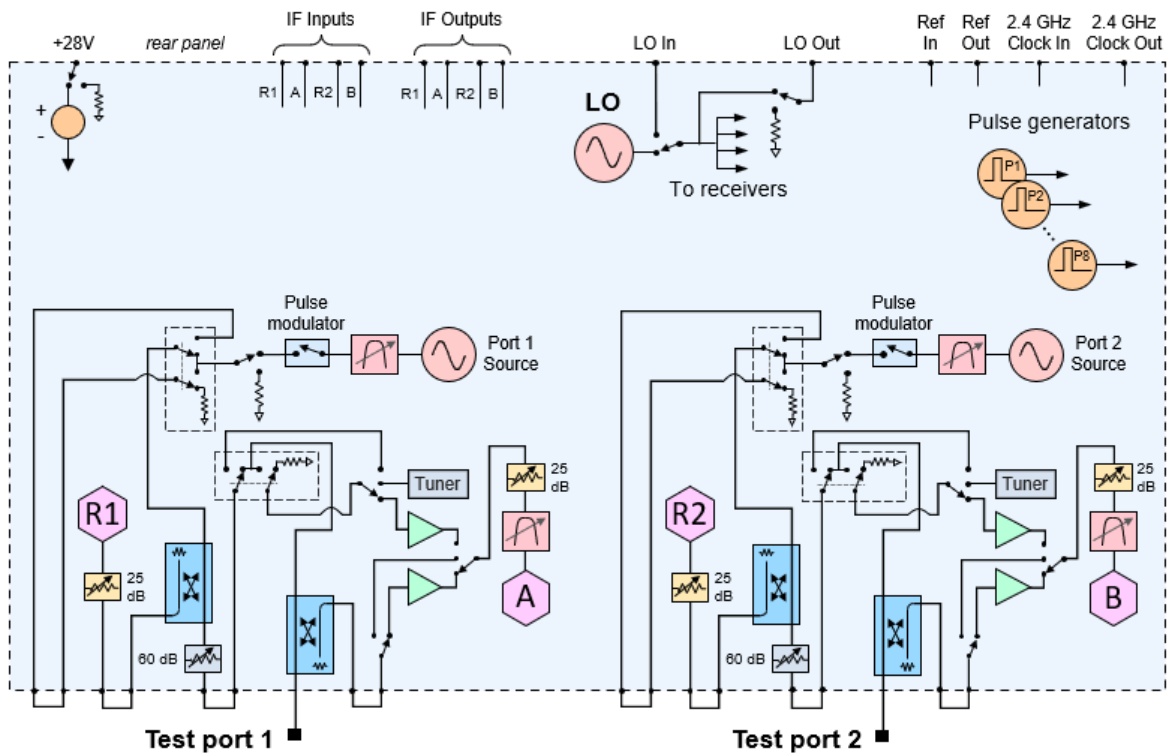



## 2-ports, source attenuators, bias tees, with configurable test set (Option 241)

This test set option includes the same hardware as Option 231: four front-panel access loops, a source attenuator, and a switched-gain test receiver with pre-selection filters for each port, and eight pulse generators and optional receiver attenuators and pulse modulators. In addition, this option provides bias tees for each port.

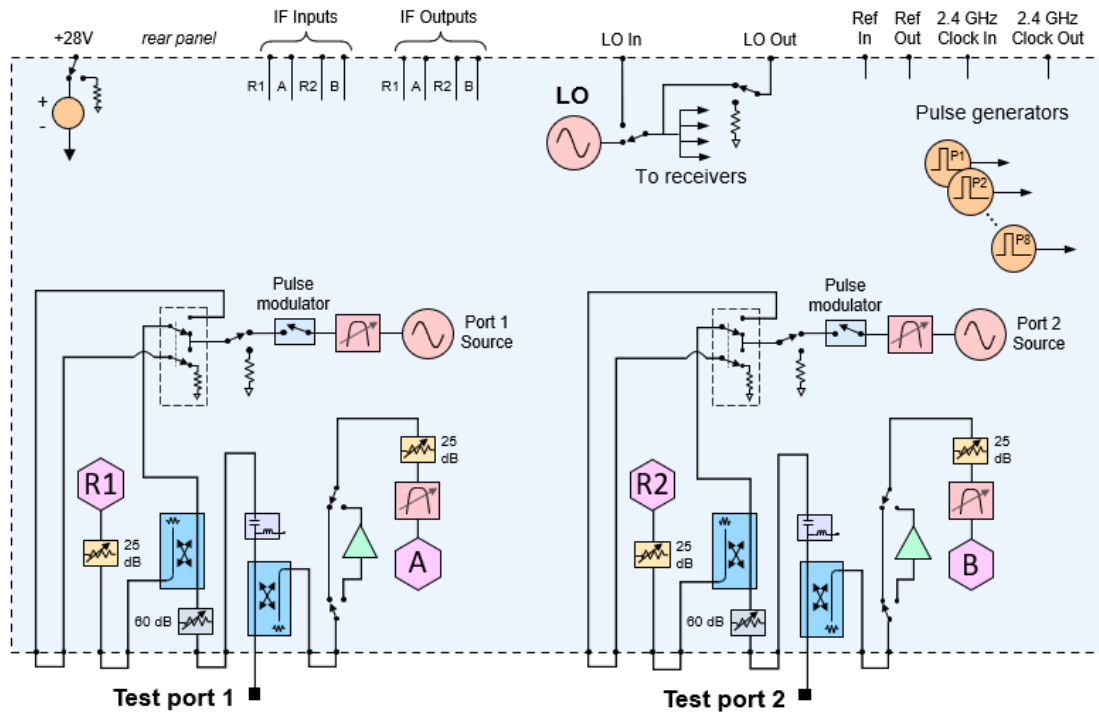

## 2-ports, source attenuators, bias tees, low-noise receiver with configurable test set (Option 249)

This test set option includes the same hardware as Option 241: four front-panel access loops, a source attenuator, a switched-gain test receiver with pre-selection filters, and a bias tee for each port, and eight pulse generators and optional receiver attenuators and pulse modulators. In addition, this option provides a low-noise receiver on port 2 and a noise tuner on port 1. Option NR1 adds a low-noise receiver to port 1 and a built-in noise tuner to port 2 for reverse noise figure measurements.

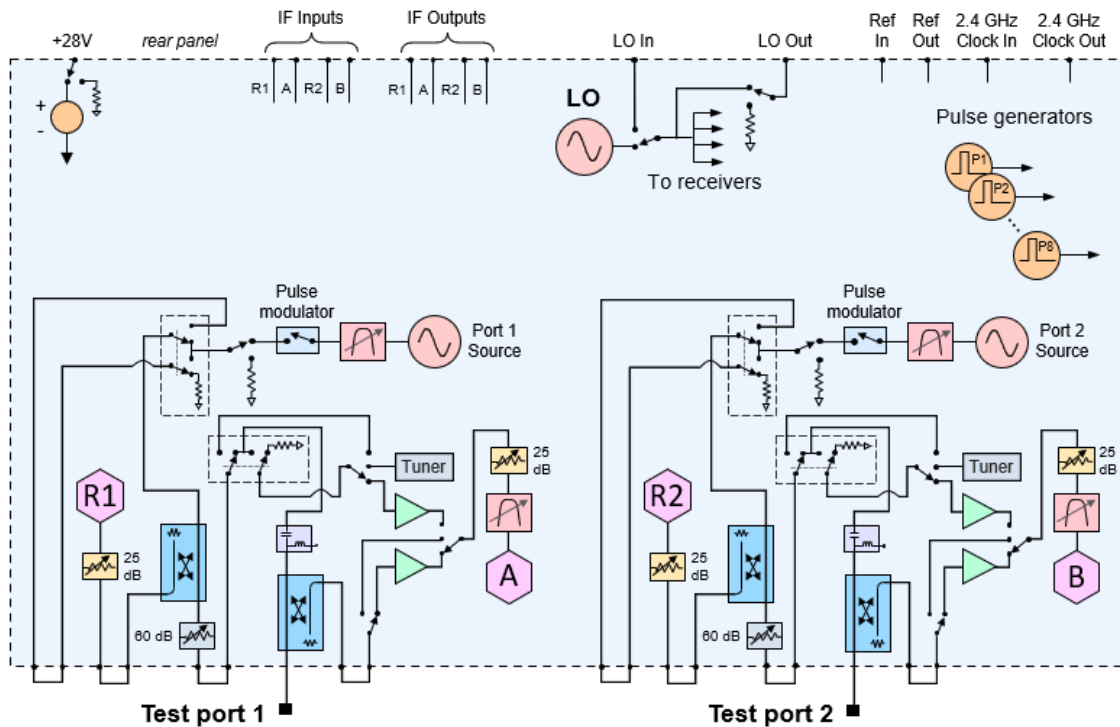

## 4-port test set options

Four-port test set options come with four sources that are tuned to the same frequency without one of these software licenses: S93080/029/082/083/084/086/087/089/090x/093/094B. Having at least one of these software licenses allows independent frequency control of source 1 and source 3, with the limitation that the frequency of source 2 will be the same as source 1 and the frequency of source 4 will be the same as source 3. Independent frequency control for all four sources requires Option 4SS and at least one of the software licenses mentioned above.

If bias tees are not included, the maximum power rating on the test port couplers is +43 dBm. If bias tees are included, the maximum power rating on the test port couplers is limited to +30 dBm. In either case, additional attenuators or isolators are typically required to protect other components inside the instrument.

## 4-ports, source attenuators, with configurable test set (Option 431)

This 4-port test set option comes with four front-panel access loops, a source attenuator, and a switched-gain test receiver with pre-selection filters for each port, and eight pulse generators and optional receiver attenuators and pulse modulators. The loops provide access to the signal path (a) between the source output and the reference receiver, (b) between the source output and the directional coupler thru arm, (c) between the coupled arm of the directional coupler and the test port receiver, and (d) to the mechanical switch of the source output as a switchable source loop.

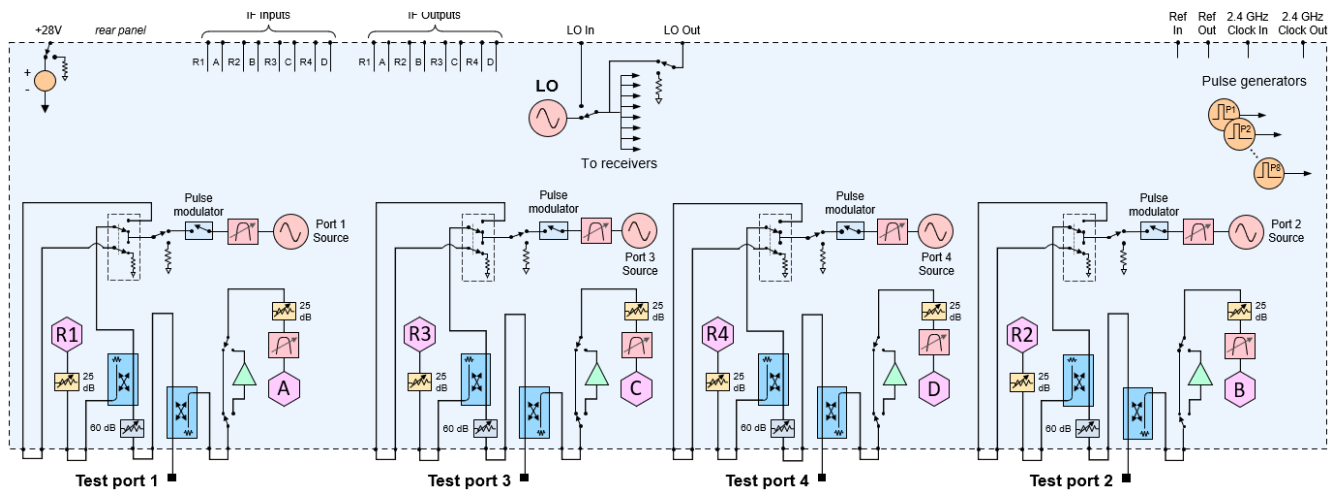

## 4-ports, source attenuators, low-noise receivers with configurable test set (Option 439)

This test set option includes the same hardware as Option 431: four front-panel access loops, a source attenuator, and a switched-gain test receiver with pre-selection filters for each port, and eight pulse generators and optional receiver attenuators and pulse modulators. In addition, this option provides a low-noise receiver on port 2 and a noise tuner on port 1. Option NR1 adds a low-noise receiver to port 1 and a built-in noise tuner to port 2 for reverse noise figure measurements.

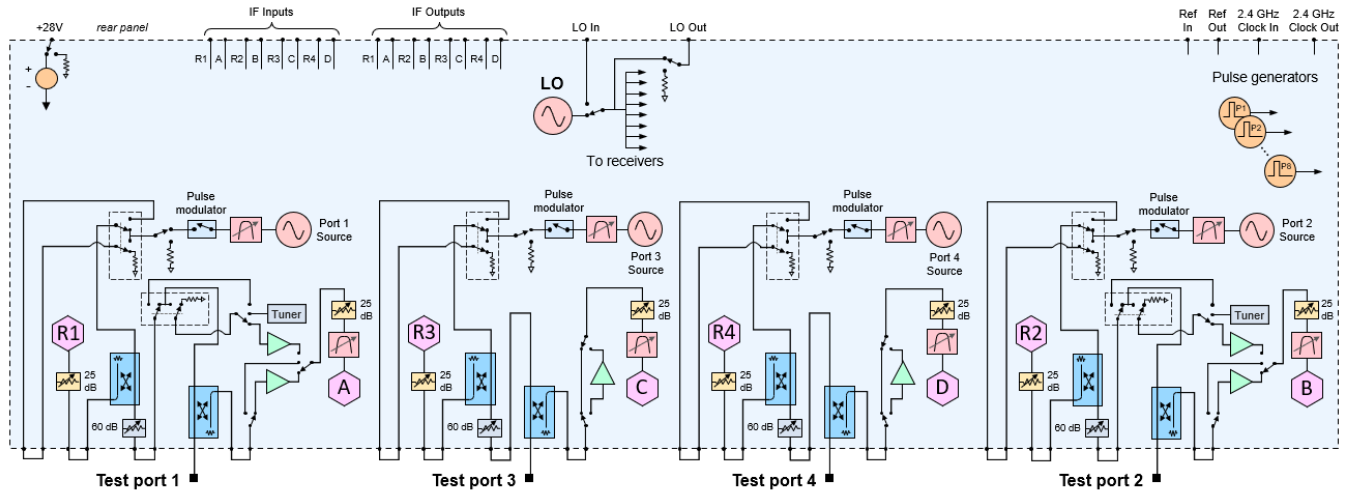

## 4-ports, source attenuators, bias tees, with configurable test set (Option 441)

This test set option includes the same hardware as Option 431: four front-panel access loops, a source attenuator, and a switched-gain test receiver with pre-selection filters for each port, and eight pulse generators and optional receiver attenuators and pulse modulators. In addition, this option provides bias tees for each port.

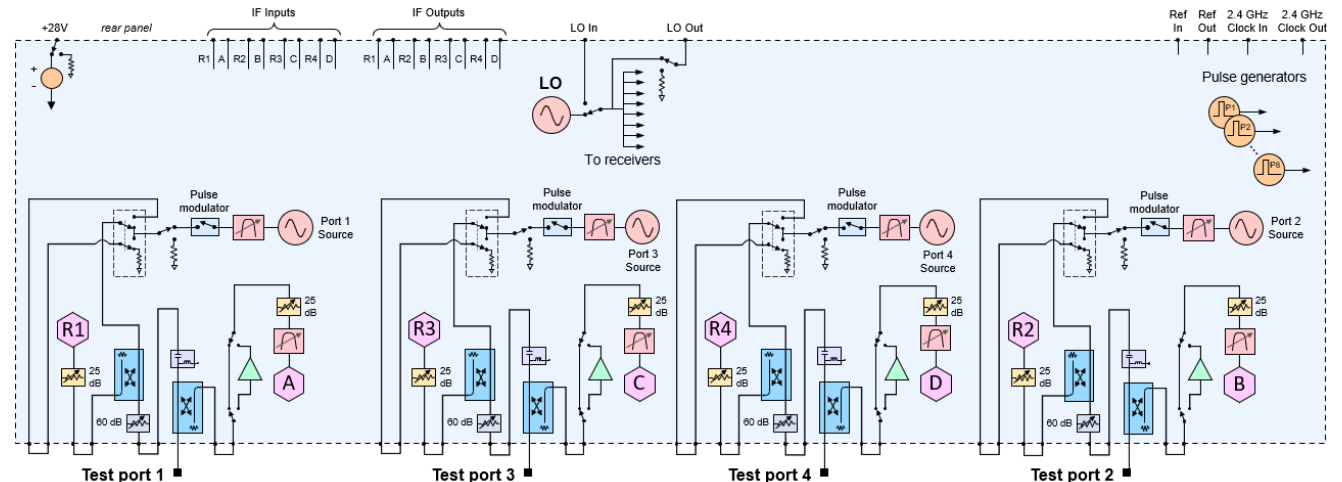

## 4-ports, source attenuators, bias tees, low-noise receiver with configurable test set (Option 449)

This test set option includes the same hardware as Option 441: four front-panel access loops, a source attenuator, a switched-gain test receiver with pre-selection filters, and a bias tee for each port and eight pulse generators and optional receiver attenuators and pulse modulators. In addition, this option provides a low-noise receiver on port 2 and a noise tuner on port 1. Option NR1 adds a low-noise receiver to port 1 and a built-in noise tuner to port 2 for reverse noise figure measurements.

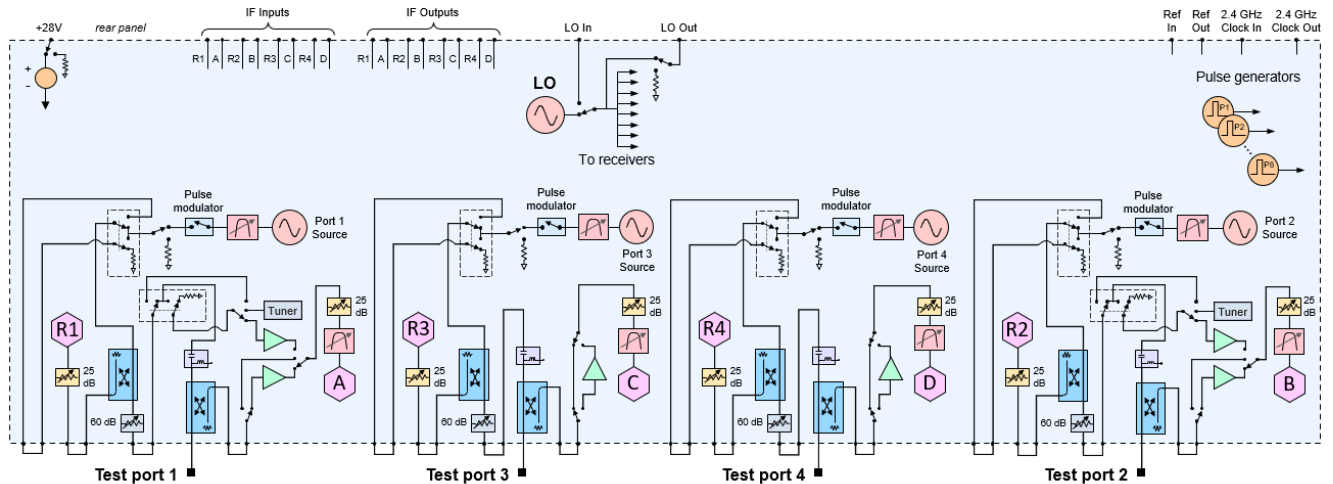

## 4-ports, combiner with configurable test set (Option 451)

This 4-port test set option comes with four front-panel access loops and a switched-gain test receiver with pre-selection filters for each port and eight pulse generators and optional receiver attenuators and pulse modulators but no source attenuators. This option also includes an internal combiner on port 1 to combine the output of source 1 and source 3 for two-tone intermodulation distortion measurements. Option CB2 adds a combiner on port 2 to combine the output of source 2 and source 4 for reverse two-tone intermodulation distortion measurements.

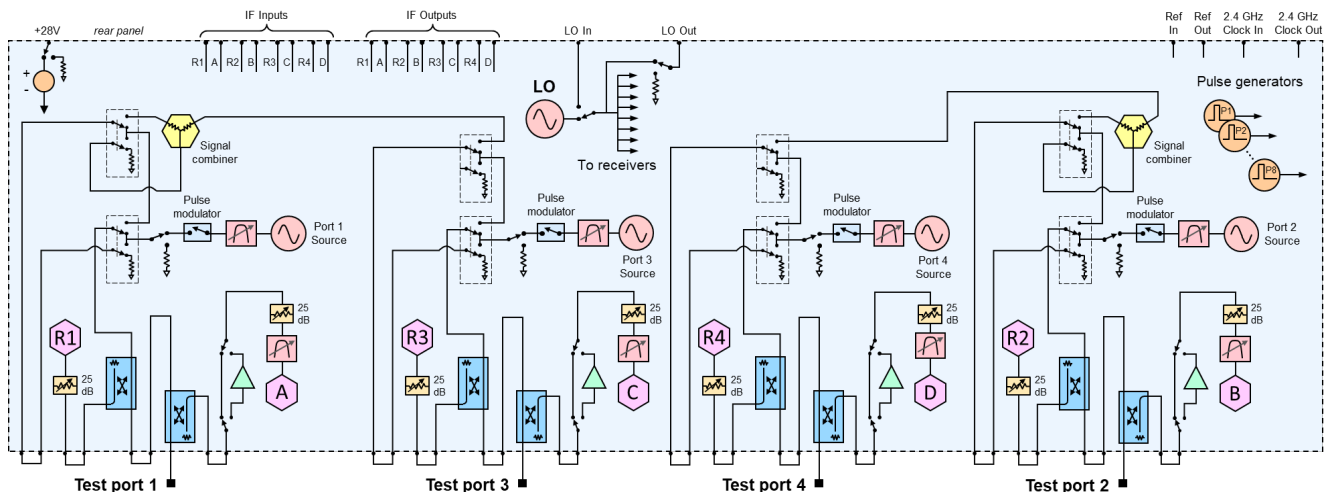

## 4-ports, combiner with configurable test set (Option 471)

Along with the hardware of Option 451, this test set option comes with a source attenuator for each port.

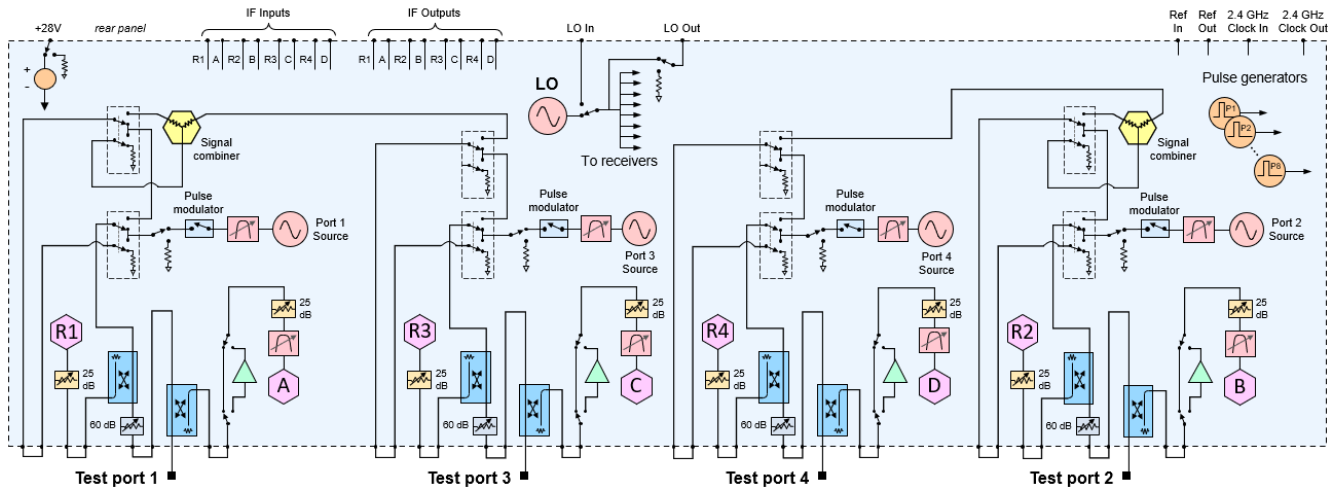

## 4-ports, combiner, low-noise receiver with configurable test set (Option 479)

Along with the hardware of Option 471, this test set option comes with a low-noise receiver on port 2 and a noise tuner on port 1. Option NR1 adds a low-noise receiver to port 1 and a built-in noise tuner to port 2 for reverse noise figure measurements.

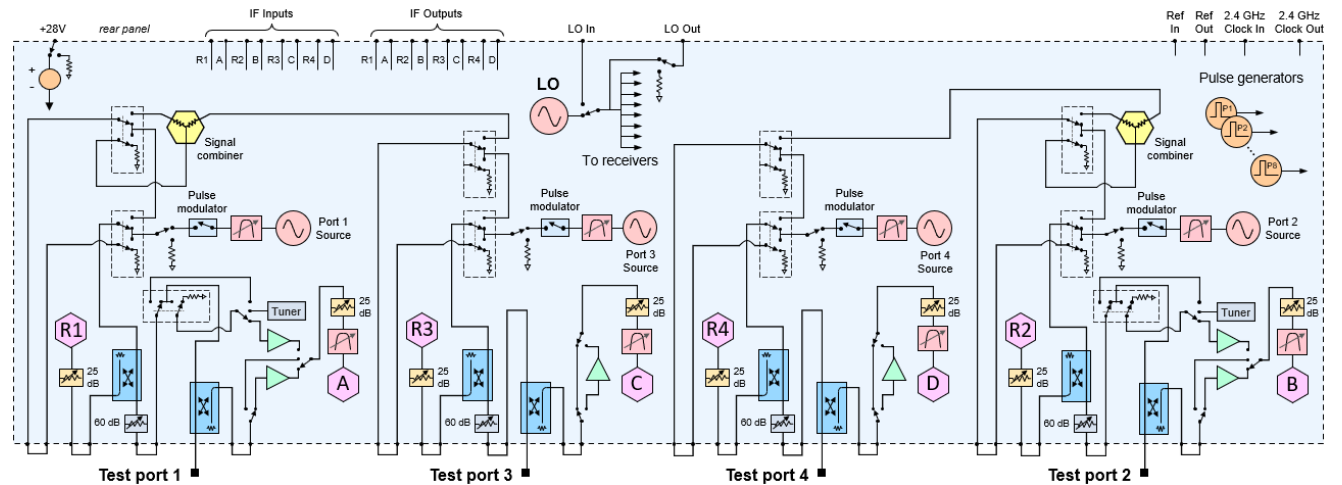

## 4-ports, combiner, bias tees with configurable test set (Option 481)

Along with the hardware of Option 471, this test set option comes with bias tee at each port.

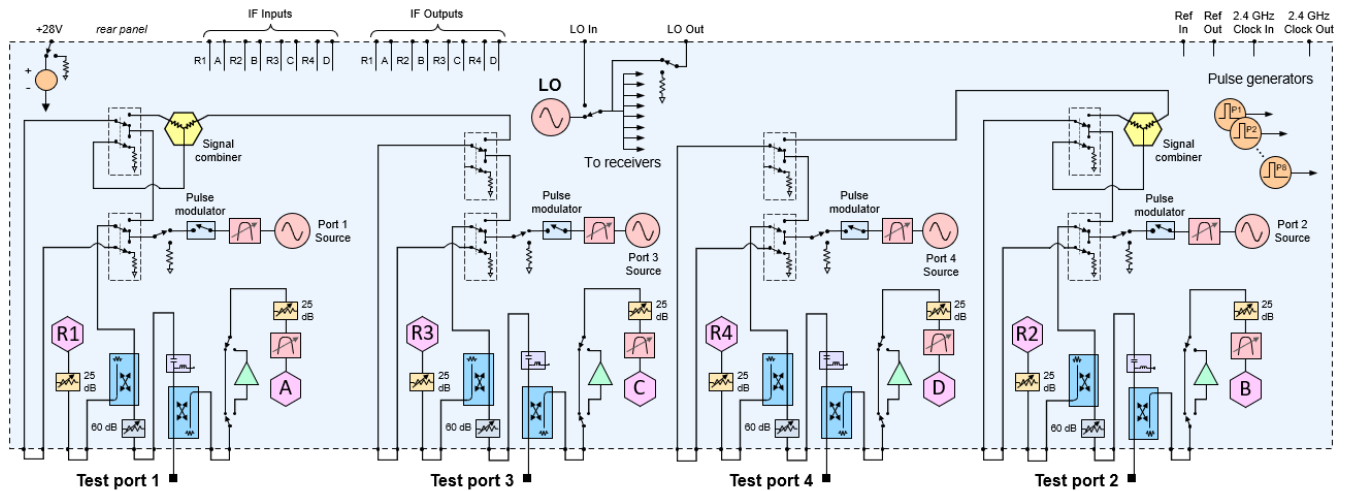

## 4-ports, combiner, bias tees, low-noise receiver with configurable test set (Option 489)

Along with the hardware of Option 481, this test set option comes with a low-noise receiver on port 2 and a noise tuner on port 1. Option NR1 adds a low-noise receiver to port 1 and a built-in noise tuner to port 2 for reverse noise figure measurements.

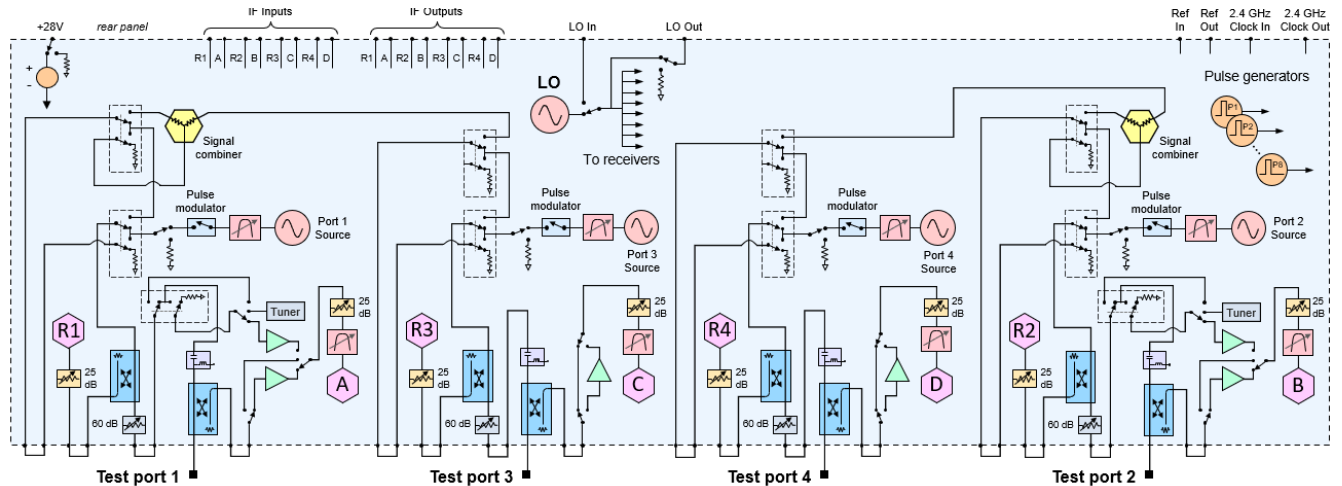

# Literature Information

- PNA-X Vector Network Analyzer Configuration Guide [3124-1588.EN](#)

# Web Resources

- Keysight Vector Network Analyzer Page - [www.keysight.com/find/na](http://www.keysight.com/find/na)
- Keysight Vector Network Analyzer Software Page - [www.keysight.com/find/vnasoftware](http://www.keysight.com/find/vnasoftware)
- Keysight Electronic Calibration (ECal) Module Page - [www.keysight.com/find/ecal](http://www.keysight.com/find/ecal)



# Keysight Support Services

Accelerate your learning curve, enhance your test uptime, and confidently guarantee your instrument accuracy with Keysight Support Services. Keysight Services are here to support your test needs with expert technical support, instrument repair and calibration, training, alternative acquisition program options, and more.

A KeysightCare agreement provides dedicated, proactive support through a single point of contact for an extensive group of instruments, software, and solutions to ensure optimal uptime, with fast response times and resolution. Explore the services that are right for you.

## Keysight Services

Offering	Benefits
<p><b>KeysightCare</b></p> 	<p>KeysightCare provides elevated support for Keysight instruments and software, with access to technical support experts who respond within a specified time and ensure committed repair and calibration turnaround times (TAT). KeysightCare offers multiple service agreement tiers, including KeysightCare Assured, Enhanced, and Application Software Support. See the <a href="#">KeysightCare data sheet</a> for details.</p>
<p>KeysightCare Assured</p>	<p>KeysightCare Assured provides a commitment to respond to your engineer's technical needs quickly. When unexpected repairs are necessary, you can count on a committed repair service turnaround time to get you back up and running.</p>
<p>KeysightCare Enhanced</p>	<p>KeysightCare Enhanced includes all the benefits of KeysightCare Assured plus Keysight's accurate and reliable <a href="#">Calibration Services</a>, accelerated and committed TAT, and technical response.</p>
<p><b>Keysight Support Portal &amp; Knowledge Center</b></p>	<p>All KeysightCare tiers include access to the Keysight Support Portal, where you can manage support and service resources related to your assets, such as service requests and status, or browse the Knowledge Center.</p>
<p><b>Education Services</b></p>	<p>Build confidence and gain new skills to make accurate measurements, with flexible Education Services developed by Keysight experts. Including Start-up Assistance.</p>
<p><b>Alternative acquisition options</b></p>	
<p><b>KeysightAccess</b></p>	<p>Reduce budget challenges with a lease-based subscription service that offers low monthly payments, enabling you to get the instruments, software, and technical support you want for your test needs.</p>

## Recommended services

Maximize your instrument uptime and confidently make accurate measurements by securing technical support, repair, and calibration services with committed response and turnaround times. High-performance instruments include 1 year of KeysightCare Assured or KeysightCare Warranty Plus. Obtain multi-year KeysightCare upfront to eliminate the need for lengthy and tedious paperwork and yearly requests for maintenance budget. Plus, you benefit from secured service for 2, 3, or 5 years.

Service	Function
<b>KeysightCare Enhanced*</b>	<b>Includes tech support, warranty and calibration</b>
R-55B-001-1	KeysightCare Enhanced – Upgrade 1 year
R-55B-001-2	KeysightCare Enhanced – Extend to 2 years
R-55B-001-3	KeysightCare Enhanced – Extend to 3 years (Recommended)
R-55B-001-5	KeysightCare Enhanced – Extend to 5 years (Recommended)
<b>KeysightCare Assured*</b>	<b>Includes tech support and warranty</b>
R-55A-001-2	KeysightCare Assured – Extend to 2 years
R-55A-001-3	KeysightCare Assured – Extend to 3 years
R-55A-001-5	KeysightCare Assured – Extend to 5 years
<b>Start-Up Assistance</b>	
PS-S40-01	Included – instrument fundamentals and operations starter
PS-S40-04	Recommended – instrument fundamentals and operations starter
PS-S40-02	Optional, technology & measurement science standard learning

\* Limited availability might apply. Please review the service definition tool for model number availability and the datasheet for country availability. Coverage might be limited to KeysightCare Warranty Plus (R-55F-001). If KeysightCare Enhanced is available. R-55B-001-2/3/5 must be ordered with R-55B-001-1.



Keysight enables innovators to push the boundaries of engineering by quickly solving design, emulation, and test challenges to create the best product experiences. Start your innovation journey at [www.keysight.com](http://www.keysight.com).

This information is subject to change without notice. © Keysight Technologies, 2024 - 2025, Published in USA, August 1, 2025, 3124-1589.EN