



Terminator™

Far End Terminating Device

The CopperPro™ family of loop testers from Fluke Networks packs a full complement of test and troubleshooting capabilities into one rugged, integrated tool for OSP technicians. Now we've expanded its capabilities even further with Terminator – an accessory module to the 990DSL CopperPro™ that lets you perform terminated transmission testing quickly. Easily. Single-handedly.

Together, the CopperPro and Terminator are a major advance in qualifying and troubleshooting copper access network circuits, including HDSL2/4. Nothing else on the market offers a more complete and effective solution for reducing failure frequency, repeats, and chronic problems with special services circuits.

“Terminate” wasted time, money and dispatches

Just attach the battery-powered Terminator to the far end of a cable pair. Together with a single 990 CopperPro, Terminator provides VF and WB terminations and tones for terminated transmission testing. It also supports the 990DSL's composite tone generation capability for high-speed ADSL, special services, and wideband longitudinal balance tests.

The bottom line? By reducing failure frequency, repeats and chronic problems, Terminator puts an end to unnecessary dispatches and fines.

Save time and money. Gain higher performance.

- Saves money and optimizes your workforce with “one tech out” terminated testing of out-of-service pairs
- High-speed acceptance/qualification tests, including loop attenuation – a must for HDSL2/4
- Robust error checking at start-up eliminates time-consuming false starts and assures reliable communication with the CopperPro
- High-speed testing makes technicians more efficient; the CopperPro's unique composite tone capability can sweep thousands of frequencies in seconds

Terminator: one add-on module; 13 testing advantages

1. Loop terminations and VF/WB single tones for testing on either of two pairs (Pair 1 and 2)
2. Bridging/splitting access between Pair 1 and Pair 3 (CO Pair)
3. Composite VF and WB tones for greatly increased testing speed
4. DTMF signaling control on both Pair 1 and Pair 2 (Pair 1 alone, if powered down)
5. Signaling and testing on the same pair (either Pair 1 or 2)
6. Extremely low-power mode when turned off
7. DTMF transceiver switchable via relay to either Pair 1 (default) or Pair 2, or



removed from both for a preset time interval whenever its input impedance would affect the 990 CopperPro measurement from the far end (i.e., shorts and grounds, or opens)

8. Operable from a standard butt-set, when line powering is present (i.e., idle POTS line)
9. DTMF command protocol allows for “Ack/Nack” closed-loop feedback response to control commands, increasing reliability
10. Tracing Tone mode (TR metallic 577 Hz signal)
11. Powered by a standard, off-the-shelf 9 VDC alkaline non-rechargeable battery
12. Battery cover removable without using a tool
13. Operates from an external 12-15 VDC power source, such as the AC and DC power cords provided with the 990 CopperPro, automatically disconnecting the internal battery when plugged in

Team up Terminator with the 990 CopperPro – and see what a difference Fluke Networks' SuperVision makes.

Why Terminator and CopperPro together are the only proven way to qualify HDSL

Advances in DSL (digital subscriber line) technologies have had a dramatic impact on the availability and deployment of broadband service. High-speed links carrying voice, data and video services can be deployed quickly over existing outside plant copper cable. While some circuits turn up with minimal effort, many suffer problems from the outset.

Traditional testing methods will no longer do the job. HDSL2 and HDSL4 don't use repeating signals that can be replicated with BERT and Nyquist tests used in the past. Instead, they use complex TCPAM technology, which requires a different testing procedure.

The 990DSL CopperPro and Terminator feature automatic tests designed specifically to address this problem. CopperPro and Terminator prequalify pairs for HDSL2 or HDSL4 in less than two minutes, and help locate facilities problems that generate errors or cause circuits to fail.

HDSL2/4 tests include:

- Foreign voltage to uncover facility damage
- Shorts and grounds to identify any short or crossed conductors, failed insulation or water in the cable
- Opens, capacitive length and balance, which, along with the resistance tests, can help determine if water, split pairs or an unknown bridge tap is present
- Signal loss and slope in the voice band to help detect bridge taps and other anomalies

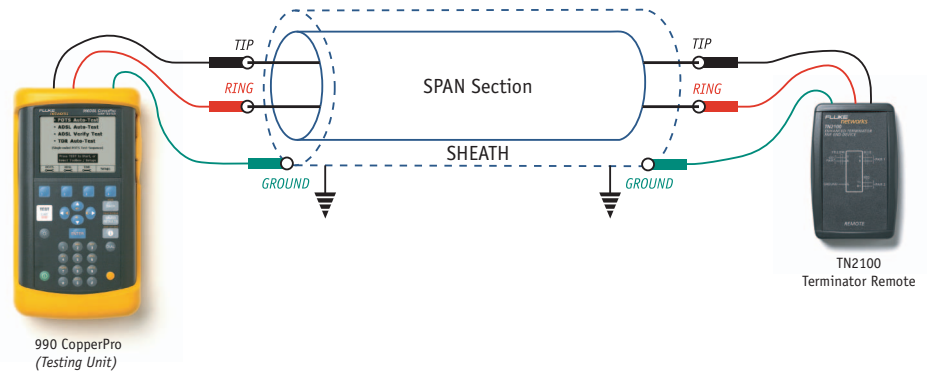

- Metallic noise, power influence and longitudinal balance at voice band and data frequencies to assess how well the pair can "self-shield" itself from the effects of noise from the environment or in the cable
- Wideband circuit noise and level across the entire frequency range (spectral noise) to make sure ambient noise in the HDSLx pass band are below acceptable levels
- Loop resistance and resistive balance and length to assure that splices, gauge changes or other impairments don't compromise the long-term reliability of the circuit
- Loop attenuation with pass/fail PSD (power spectral density) masks for upstream and downstream to assure the performance of the TCPAM encoded transmission.

CopperPro Reporter Software

CopperPro Reporter Software allows you to document and report test results quickly and easily using Microsoft Excel on your computer. It is available as a free download to all CopperPro customers. Simply visit www.flukenetworks.com/copperprosoftware

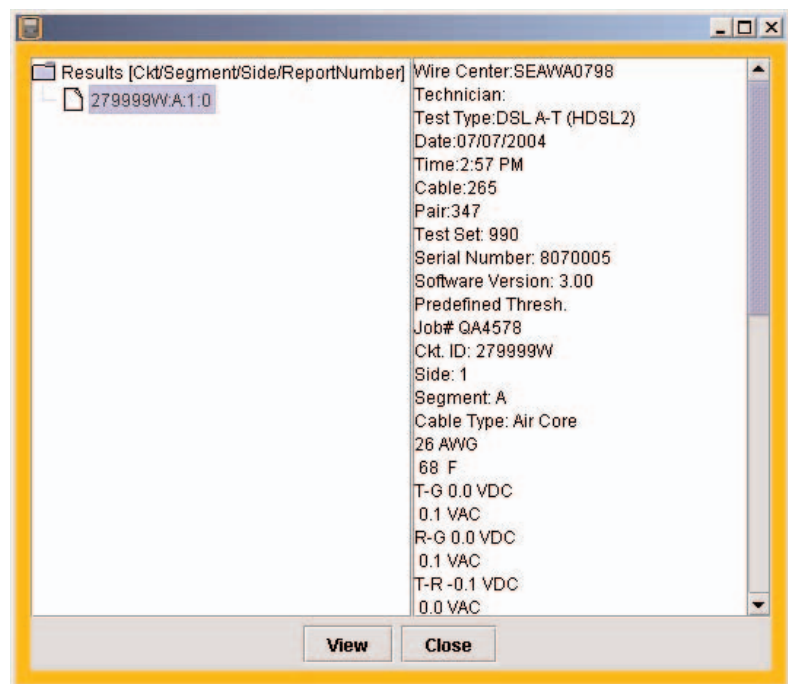



Fluke Networks delivers SuperVision solutions for the outside plant

Fluke Networks products enable you to correct local loop database errors, qualify lines for DSL service, test and document cable conformance and install and troubleshoot voice and data services. Our telecom solutions allow you to maintain and manage your outside plant more efficiently and cost effectively so you can increase revenue, profitability and customer satisfaction.

For more information, or to contact your local Fluke Networks representative, call (800) 283-5853 or email copperpro@flukenetworks.com

Specifications

Powering	
Source	Internal: replaceable 9 VDC alkaline battery External: 9-18 VDC AC power adapter or DC auto power cord
Shelf life	2 months (battery installed)
Operating life	40 hours (typical usage)
Input Voltage Protection	
Test lead inputs	± 350 VDC and 250 VAC, TG and RG
VF Transmit Frequencies	
Amplitude, single tones	0.0 dBm ± 0.5 dB
Amplitude, composite SmartTone	-13 dBm composite*
Frequency range	300 Hz to 20 kHz, ± 0.1%
Transmit impedance	600 or 900 ohms
WB Transmit Frequencies	
Amplitude, single tones	0.0 dBm ± 0.5 dB
Amplitude, composite tone-sets	Variable, depending on tone-set*
Frequency range	10 kHz to 1200 kHz
Frequency resolution	Multiples of 508.626 Hz
Impedance	100 or 135 ohms
Tracing Tone	
Frequencies	577.5 Hz : 500 ms on, 500 ms off, Metallic (TR)
Amplitude	> 3.5 Vpp

* Composite SmartTone available only on TN2100 model.

Ordering information

Model	Description
TN2000	Basic Terminator Far End Device
TN2100	Enhanced Terminator Far End Device
TN-LEADS-P	Test Lead Set, Plain Clip
TN-LEADS-B	Test Lead Set, Bed-Of-Nail Clip
TN-LEADS-S	Test Lead Set, Spike Clip
TN-LEADS-SB	Test Lead Set, Spike + Bed-Of-Nail Clip

NETWORK SUPERVISION

Fluke Networks
P.O. Box 777, Everett, WA USA 98206-0777

Fluke Networks operates in more than 50 countries worldwide. To find your local office contact details, go to www.flukenetworks.com/contact.

©2004 Fluke Corporation. All rights reserved.
Printed in U.S.A. 1/2005 2134876 D-ENG-N Rev B