



**Advanced Test Equipment Rentals**  
**www.atecorp.com 800-404-ATEC (2832)**

March, 1989



## **Dynatel® 500A/P Cable Locator and Dynatel® 573A/P Earth Return Fault and Cable Locator Operator's Manual**



## **Dynatel® Cable and Earth Return Fault Locators for Electrical Power Applications**

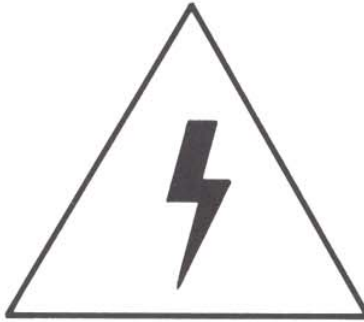

### **W A R N I N G**

A potential for electrical shock exists when using on cables energized with electrical power. Use appropriate safety procedures.

DO NOT USE ON CABLES CARRYING IN EXCESS OF 600 VOLTS RMS.

<b>Contents</b>	<b>Page</b>
<b>1. General</b> .....	2
<b>2. Description</b> .....	2
500A/P Transmitter and Receiver .....	2
573A/P Transmitter and Receiver .....	5
<b>3. Locating Earth Return Faults</b> .....	7
Checking for Sheath Damage .....	7
Fault Location Setups .....	8
Pinpointing the Fault .....	9
Faults Under Pavement .....	10
<b>4. Cable and Conductor Location</b> .....	12
Transmitter Operation .....	12
RF (Radio Frequency) .....	12
Direct Connection .....	13
Inductive Coupling .....	13
General Induction .....	13
AUDIO Frequency .....	14
Receiver Operation .....	14
NULL Reception .....	14
PEAK Reception .....	15
<b>5. Determining Cable Depth</b> .....	15
Direct Measurement .....	15
Triangulation .....	15
<b>6. Special Applications</b> .....	16
Cable Identification .....	16
RF Tone .....	16
AUDIO Tone .....	16
POWER .....	17
Slack Loops and T-Splices .....	17
Unknown Laterals .....	17
Pedestals and Closures .....	18
Service Drops .....	18
Clear, Severed End .....	18
Connection Tips .....	19
<b>7. Care and Maintenance</b> .....	19
Battery Test .....	19
Replacement .....	19
Life .....	20
Fuses .....	20
<b>8. Returns</b> .....	20
<b>9. Repairs</b> .....	21

## 1. General

- 1.01 This section covers the description, use, care and maintenance of the Dynatel 500A/P Cable Locator and the Dynatel 573A/P Earth Return Fault and Cable Locator (Fig. 1).



Fig. 1 — The Dynatel 500A/P Cable Locator and The Dynatel 573A/P Sheath Fault/Cable Locator

- 1.02 These portable, battery-powered tone sets detect and locate the path of buried power cable. Each can be used on cable and wire runs behind walls and under floors. In addition, the Dynatel 573 A/P will test for and pinpoint the location of earth faults due to cable damage by detecting the point of current flow to ground—even when multiple, closely-spaced faults are present. Both sets will identify and trace primary and secondary cables, service drops, and severed cable ends, whether direct buried or in conduit, and they will identify a single cable in multiple service areas.

- 1.03 The sets locate cables without taking them out of service or interfering with power transmission. The receiver alone may be used to detect and trace the magnetic field of a working power cable. In congested joint service areas, a high-frequency RF tone is put on the cable or conductor for most locates of less than a mile in distance. For greater tracing distances, or for continuously grounded cables, a Low- or Audio-frequency tone is provided.

- 1.04 The receivers are physically independent of the transmitter in all operations and have one-hand adjustment at normal walking speeds. They are highly sensitive to all the tracing tones. This sensitivity is continually adjustable to prevent error due to overdriven tone. Received tone strength is indicated audibly through the loudspeaker and visibly on the meter. The Sensitivity Control adjusts both loudspeaker volume and meter deflection. On the 573A/P, direction to a sheath fault is indicated by meter deflection to a red or green zone.

## 2. Description

- 2.01 **THE DYNATEL 500A/P CABLE LOCATOR:** The 500A/P consists of a transmitter, a receiver, and accessory items (Fig. 2). The transmitter and receiver cases are made of high-density polyethylene for light weight and high durability, and are colored bright yellow for visibility. Both are water-resistant in wet-weather operation. For compact storage and carrying, the receiver and accessories fit into the transmitter case. To preserve battery life, "off" switches are activated on both Transmitter and Receiver when the receiver is fitted into the transmitter case. A stainless steel ground rod is clipped inside the set's lid.

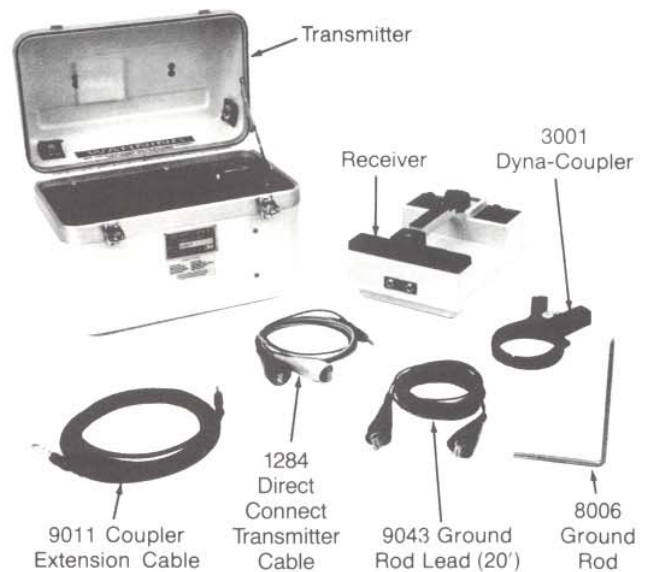

Fig. 2 — The 500A/P Cable Locator with Accessory Units

- (a) The TRANSMITTER (Fig. 3) has a single TRANSMITTER OUTPUT selector switch on the panel next to the accessory storage well. Above the switch is the OUTPUT-Test meter which indicates transmitter output level and Volt/Ohmmeter test conditions.

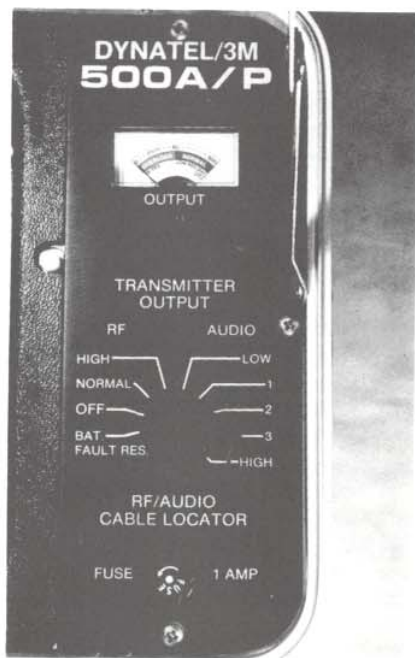

Fig. 3 — The 500A/P Transmitter Unit Control Panel

- 1) The OUTPUT-TEST meter has three indicator bands to show test conditions (Fig. 4).



Fig. 4 — 500A/P Transmitter Meter

**VOLTS/DANGER:** With the transmitter in the OFF position, the meter will indicate voltages when metallic attachment is made to cable neutral or conductor. Up to 50 volts present is acceptable for test. If more than 50 volts are indicated (the "Danger" zone) dangerous voltages are present which could damage equipment and cause operator injury.

**CAUTION:** The 500A/P and 573A/P are not tested or approved for direct connection to energized conductors. For maximum safety and protection, always verify that a conductor is completely de-energized, and any residual charges have been discharged, before connecting the transmitter. Wear suitable safety apparel when making the connection.

**OVERLOAD/HI RES.; NORMAL/LOW RES.:** With the Locate Mode selector in BAT./FAULT RES. position, this band shows metallic test conditions and indicates optimum transmitter adjustment.

**BAT. OK:** Indicates acceptable battery level when the OUTPUT LEVEL selector is turned to BAT./FAULT RES.

- 2) The TRANSMITTER OUTPUT selector is a nine position switch for selecting the output mode, output level, Volt-Ohmmeter functions and a battery test. The positions are, clockwise from lower left:

**BAT./FAULT RES.:** Battery test position. A spring-return, momentary-contact switch puts load on the transmitter batteries for test when the 1284 Direct Connect Transmitter Cable is connected and its clips shorted (See Par. 7.01). This position also indicates circuit integrity for tracing the coiling in the AUDIO mode.

**OFF (Voltage):** Transmitter battery power is off. **IMPORTANT:** In this position, the set acts as a Voltmeter when attached with the 1284 Direct Connection Transmitter Cable to a conductor. The meter will indicate the presence of AC or DC voltage up to 600 volts.

**RF NORMAL:** Sets transmitter output power to Radio Frequency (320,000 Hz) mode at NORMAL level. This level is used for most short locates and provides maximum battery life.

**RF HIGH:** Sets transmitter output to Radio Frequency mode at HIGH level. This will provide a noise-free tracing tone for distances up to a mile, but will reduce battery life.

**AUDIO (LOW, 1, 2, 3, HIGH):** Selects the AUDIO frequency (577.5 Hz) for tracing at great distance or through continually grounded cable such as lead sheath. Use the highest setting where the meter needle deflects farthest into the green.

- 3) The TRANSMITTER OUTPUT jack, on the right side of the case below the transmitter panel, is a standard telephone jack for connecting accessories for either direct connection or inductive coupling in RF tone with the Dyna-Coupler<sup>®</sup>.
- (b) The 500A/P RECEIVER operating panel (Fig. 5) has two selector switches flanking a level reference meter and sensitivity control. The tracing frequency is selected by the TONE SELECT switch, and the RECEIVER MODE switch controls the receiver operating modes.

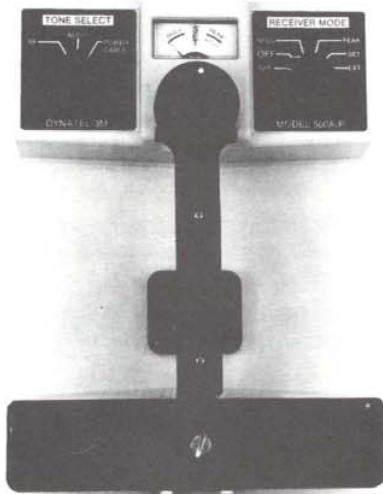

Fig. 5 — 500A/P Receiver Unit

- 1) TONE SELECT is a three-position switch to select the tracing frequency. RF and AUDIO detect signals generated by the transmitter. The POWER CABLE position detects the magnetic field of 60 Hz AC current without the need for transmitted tone.
- 2) The RECEIVER MODE selector is a six-position switch which controls the following receiver operating modes:

**OFF:** Turns off receiver power.

**BAT:** Battery test position. Momentary-contact, spring-return switch puts test load on receiver batteries. (See Sec. 7 for Bat. test procedures.)

**NULL:** Selects NULL mode operation for cable location (see Par. 4.07[a]). In NULL mode, the

loudspeaker tone sharply decreases and the needle deflects to the "NULL" (left) side of the meter when the receiver is directly over the cable.

**PEAK:** Selects PEAK mode operation for cable location (see Par. 4.07[b]). In PEAK mode, with the receiver handle parallel to the cable path, the loudspeaker tone is at its highest and the needle deflects to the "Peak" (right) side of the meter when the receiver is directly over the cable.

**NOTE:** PEAK is not as sharp (well-defined) an indication as NULL. Always check any locate in both modes.

**SET:** SET mode is used to set a reference on the meter for use in cable depth determination (see Sec. 5).

**EXT:** EXT sets operation of the receiver to the external jack for use of the Dyna-Coupler. The probes are available separately.

- 3) The Receiver Signal Level Meter (Fig. 6) indicates the strength of the tone being received. Needle deflects to the right (PEAK) at greatest volume. Needle deflects to the left (NULL) for weak or canceled tone. The yellow center zone (SET) provides a reference for cable depth location. The BAT OK zone indicates acceptable battery condition.

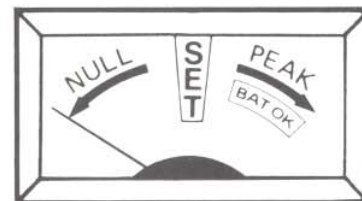

Fig. 6 — 500A/P Receiver Meter

- 4) The Sensitivity Control Knob adjusts meter sensitivity and tone volume in the loudspeaker.
- 5) The Loudspeaker provides an audible indication of tone level. It is protected from weather by an overlapping cover.
- 6) The TONE COIL jack (Fig. 7) is an input connector for use in the AUDIO mode with an exploring coil for cable identification.
- 7) The EXT Jack (Fig. 7) is a signal input jack for use with the Dyna-Coupler. This jack is energized with the RECEIVER mode switch in EXT mode.

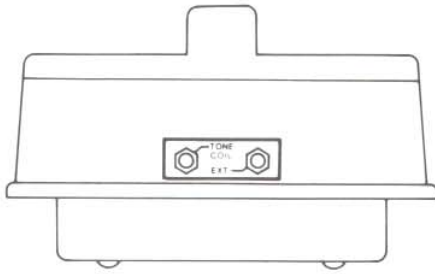

Fig. 7 — 500A/P Tone Coil and Ext. Jacks

- 8) The Battery Access Cover Screw secures the battery access cover. For battery changing procedure, see par 7.02(b).

2.02 **573A/P TRANSMITTER AND RECEIVER:** The 573A/P consists of a transmitter, a receiver, and accessory items (Fig. 8). The transmitter and receiver cases are made of high-density polyethylene for light weight and high durability, and are colored bright yellow for visibility. Both are water-resistant in wet-weather operation. For compact storage and carrying, the receiver and accessories fit into the transmitter case. To preserve battery life, "off" switches are activated on both Transmitter and Receiver when the receiver is fitted into the transmitter case. A stainless steel ground rod is clipped inside the set's lid.



Fig. 8 — The 573A/P Sheath Fault and Cable Locator with Accessory Units

- (a) The TRANSMITTER (Fig. 9) has two selector switches, OUTPUT LEVEL and CABLE/LOCATE—FAULT/LOCATE, on the panel next

to the accessory storage well. Above the switches is the OUTPUT-TEST meter which indicates transmitter output level and Volt-Ohmmeter test conditions.



Fig. 9 — 573A/P Transmitter Unit Control Panel

- 1) The OUTPUT-TEST meter has three indicator bands to show test conditions (Fig. 10).

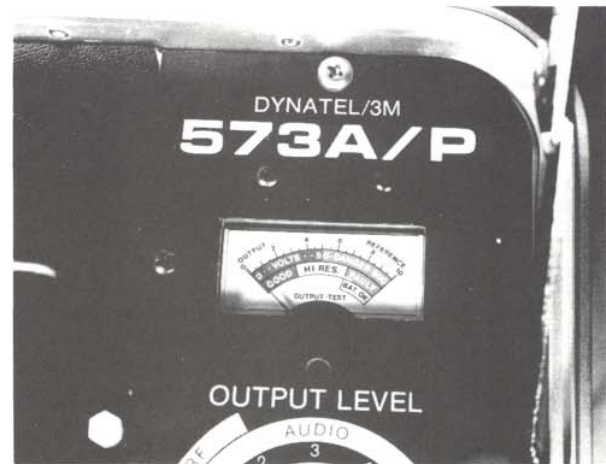

Fig. 10 — 573A/P Transmitter Meter

**OUTPUT REFERENCE:** This band, calibrated left to right from 0 to 10, shows optimum output transmission through the test positions of the OUTPUT LEVEL selector.

**VOLTS/DANGER:** With the transmitter in the OFF/VOLTS position, the meter will indicate voltages when metallic attachment is made to a concentric neutral or conductor. Up to 50 volts present is acceptable for test. If more than 50 volts are indicated (the red zone) dangerous voltages are present which could damage equipment and cause operator injury.

**GOOD/HI RES./FAULT:** With the Locate Mode selector in FAULTMETER position, this band tests sheath condition and indicates the degree of resistance in a fault.

**BAT. OK:** Indicates acceptable battery level when the OUTPUT LEVEL selector is turned to BAT./TEST.

- 2) The OUTPUT LEVEL selector is a six-position switch for selecting RF or AUDIO tone output level and a transmitter battery test. The positions are, clockwise from lower left:

**BAT./TEST:** Battery test position. A spring-return, momentary-contact switch puts load on the transmitter batteries for test.

**RF/1:** Sets transmitter output power to Radio Frequency (320,000 Hz) mode at normal level for cable location. This level is used for most short locates and provides maximum battery life.

**RF/2:** Sets transmitter output to Radio Frequency mode at HIGH level for cable location. This will provide a tracing tone for distances up to a mile.

**AUDIO/1, 2, 3, 4, 5:** Selects the AUDIO frequency (577.5 Hz) and signal level for tracing at great distance or through cables with continually grounded concentric neutrals such as unjacketed or lead sheath.

**1, 2, 3/FAULT:** Sets the output level for earth fault location in either RF or AUDIO mode.

- 3) The Locate Mode selector tests voltage and fault conditions on a cable section, and selects locate type and transmission frequency. The positions are, clockwise from lower left:

**FAULTMETER:** This momentary-contact, spring-return position tests sheath integrity. Sheath condition is indicated by needle deflection in the resistance band of the OUTPUT-TEST meter. This position also indicates ground or conductor integrity of the signal return circuit when tracing and coiling in the AUDIO mode.

**OFF/VOLTS:** Transmitter battery power is off. **IMPORTANT:** In this position, the set acts as a Voltmeter when attached to a conductor with the 1284 Direct Connection Transmitter Cable. The

meter will indicate the presence of AC or DC voltage up to 600 volts.

**CAUTION:** The 500A/P and 573A/P are not tested or approved for direct connection to energized conductors. For maximum safety and protection, always verify that a conductor is completely deenergized, and any residual charges have been discharged before connecting the transmitter. Wear suitable safety apparel when making the connection.

**CABLE LOCATE - RF:** Sets transmission to RF for cable location.

**CABLE LOCATE - AUDIO:** Sets transmission to AUDIO frequency for cable location.

**FAULT LOCATE - AUDIO:** Sets transmission to AUDIO frequency for earth fault location.

**FAULT LOCATE - RF:** Sets transmission to RF for earth fault location.

- 4) The TRANSMITTER OUTPUT jack is a standard telephone jack for direct connection, or inductive coupling with the Dyna-Coupler. Note that when no cable is plugged into this jack, RF output is fed to the internal radiating loop for General Induction.
- (b) The 573A/P RECEIVER operating panel (Fig. 11) has two selector switches flanking a level reference meter and sensitivity control. The system frequency is selected by the TONE SELECT switch, and the RECEIVER MODE switch controls the receiver operating modes.

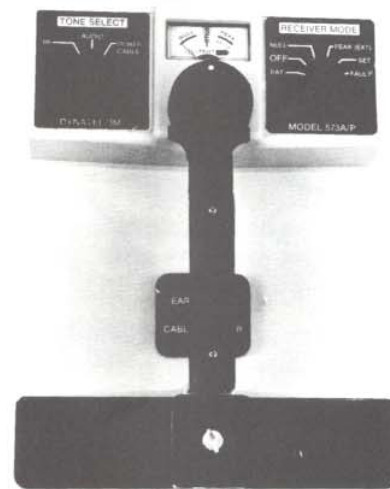

Fig. 11 — 573A/P Receiver Unit



- 1) TONE SELECT is a three-position switch to select RF or AUDIO system tones generated by the transmitter, or to detect POWER CABLE current flow in the area.
- 2) The RECEIVER MODE selector is a 6-position switch which controls the following receiver operating modes, clockwise from left.

**BAT:** Battery test position. Momentary-contact, spring-return switch puts test load on receiver batteries. (See Sec. 7 for Battery test procedures.)

**OFF:** Turns off receiver power.

**NULL:** Selects NULL mode operation for cable location (see Par. 4.07 [a]). In NULL mode, the loudspeaker tone sharply decreases and the needle deflects to the "Null" (left) side of the meter when the receiver is directly over the cable.

**PEAK (EXT):** Selects PEAK mode operation for cable location (see Par. 4.07 [b]). Also used as (EXT) to set operation of the receiver to the external jack for use of the Dyna-Coupler. In PEAK mode, with the receiver handle parallel to the cable path, the loudspeaker tone is at its highest and the needle deflects to the "Peak" (right) side of the meter when the receiver is directly over the cable.

**NOTE:** PEAK is not as sharp (well-defined) an indication as NULL but is more reliable if the cable curves or branches. Always check any locate in both modes.

**SET:** SET mode is used to set a reference on the meter for use in cable depth determination (see Sec. 5).

**FAULT:** Sets the receiver to the sheath fault locate mode.

- 3) Except in FAULT mode, the Receiver Signal Level Meter (Fig. 12) indicates the strength of the tone being received. Needle deflects to the right (PEAK) at greatest volume. Needle deflects to the left (NULL) for weak or canceled tone. The yellow center zone (SET) provides a reference for cable depth location. In fault mode, the striped red and solid green FAULT arrows indicate the leg of the Earth Contact Frame closest to a

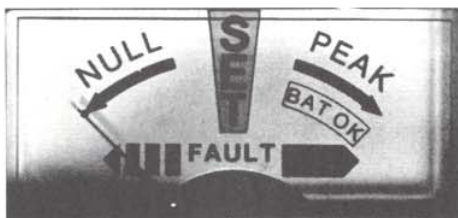

Fig. 12 — 573A/P Receiver Meter

sheath fault. The BAT OK zone shows acceptable battery condition.

- 4) The Sensitivity Control Knob adjusts tone volume in the loudspeaker. Except in FAULT mode, it also adjusts meter sensitivity.
- 5) The Loudspeaker provides an audible indication of tone level. It is protected from weather by an overlapping cover.
- 6) The EXT jack (Fig. 13) is a signal input jack for use with the Dyna-Coupler. This jack is energized with the RECEIVER MODE switch in PEAK (EXT) mode and the accessory plugged in.



Fig. 13 — 573A/P Receiver Jacks

- 7) The TONE COIL jack (Fig. 13) is an input connector for use in the AUDIO mode with an exploring coil for cable identification.
- 8) The FAULT jack (Fig. 13) connects the receiver to the 3014 Earth Contact Frame, using the 9026 Cable.
- 9) The Battery Access Cover Screw secures the battery access cover. For battery changing procedure, see par. 7.02 (b).

### 3. Locating Earth Return Faults with the 573A/P

3.01 **General:** The 573A/P will check for cable integrity by testing for conductor-to-earth resistance. If an earth return fault exists, its exact location may be pinpointed with the 3014 Earth Contact Frame. Tone transmission may be either RF or AUDIO (Frequency).

- (a) RF mode is preferred for locates of less than a mile on jacketed cable.
- (b) AUDIO mode should be used for fault locates longer than a mile. AUDIO will sometimes locate sheath damage in such continuously-grounded conductors as unjacketed concentric neutral, armored or lead sheath cable.

**NOTE:** Remove grounds at both ends and isolate the concentric neutral.

#### 3.02 Checking for Sheath Damage

- (a) **WARNING:** Make all test metallic connections with the Transmitter Output Selector left in the OFF/VOLTS position and check the meter for voltage indications. An indication of more than 50 Volts is dangerous and will damage equipment.

**CAUTION:** The 500A/P and 573A/P are not tested or approved for direct connection to energized conductors. For maximum safety and protection, always verify that a conductor is completely de-energized, and any residual charges have been discharged, before connecting the transmitter. Wear suitable safety apparel when making the connection.

**NOTE:** With the BLACK clip to ground, test the conductor with the RED clip. A meter reading showing AC voltage indicates damage to nearby power cables.

**USE EXTREME CAUTION:** Identify and isolate the damage and remove source voltage before continuing test.

- 1) With the cable isolated, plug in the 1284 Direct Connection Transmitter Cable and connect the RED clip to the concentric neutral or conductor and the BLACK lead to the ground rod. The 9043 Extension Cable may be used to extend either lead for operating convenience. Place the ground rod in good soil in line with the fault cable path and behind the transmitter (see Fig. 14).
- 2) Turn the Transmitter Locate Mode Selector to the FAULT METER position. The meter needle will deflect into one of three zones and is interpreted as follows:

**GOOD:** The green GOOD zone indicates that there is no significant fault in the cable sheath, with resistance to ground greater than 1.5 million ohms.

**HI RES.:** The white HI RES zone indicates a sheath fault of 50,000 ohms to 1.5 million ohms. **NOTE:** The combined value of multiple faults in the section will give similar or lower readings.

**FAULT:** The red FAULT zone indicates a heavy fault of less than 50,000 ohms.

**NOTE:** Failure to disconnect the grounds will produce a heavy FAULT reading.

### 3.03 Fault Location Setups

#### (a) Transmitter Output Level

- 1) With the Transmitter Output Selector in either RF or AUDIO mode, switch the OUTPUT LEVEL selector through positions 1, 2, and 3. Leave the selector set to the position which shows the highest reading as the meter needle deflects to the right.

(b) When locating an Earth Return Fault in Jacketed Cable, the transmitter attachment remains the same as for the fault test mode. Select RF (preferred) or AUDIO frequency on the receiver TONE SELECT switch to match Transmitter Output Frequency.

(c) To put both Audio tracing tone and fault locating tone on a section of Jacketed Concentric Neutral Cable, the following transmitter attachment is used.

- 1) Connect the RED clip to the faulted conductor.
- 2) Connect the BLACK clip to the ground rod placed in line with the cable path and behind the transmitter.

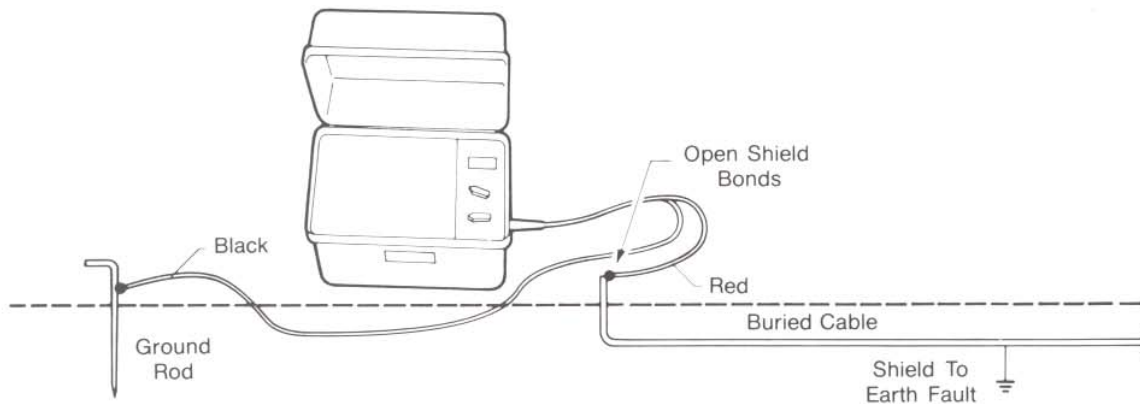

Fig. 14 — 573A/P Transmitter Attachment

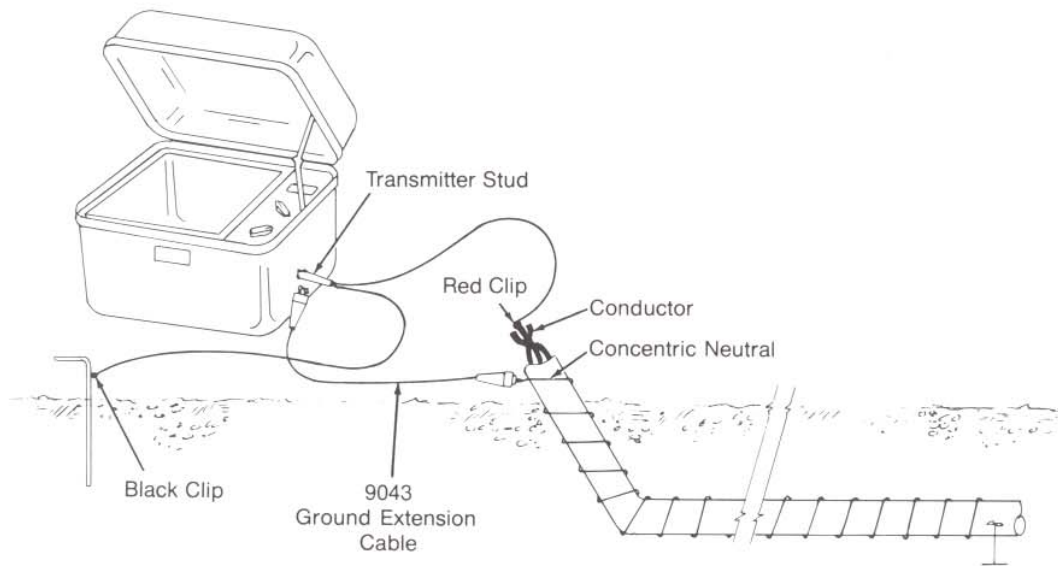

Fig. 15 — 573A/P Attachment: Transmitter Stud to Concentric Neutral

3) Connect the 9043 Ground Extension Cable between the cable neutral and the stud below the Transmitter Output Jack (see Fig. 15). This attachment will place a fault locating signal on the conductor while simultaneously pushing AUDIO tone down the neutral the length of the test section, allowing the operator to locate the entire section path.

- (d) With the receiver TONE SELECT switch set to the transmitter output tone, set the RECEIVER MODE switch to FAULT. (It will take several seconds before a proper receiver indication is given.)
- (e) Connect the 9026 Earth Frame Receiver Cable between the socket on the 3014 Earth Contact Frame and the receiver FAULT jack.

### 3.04 Pinpointing an Earth Fault.

- (a) If necessary, trace and mark the cable path. To locate an earth fault along that path,
  - 1) Hold the receiver in one hand and the Earth Contact Frame in the other with the green-banded leg to the front. At the location of the ground rod, insert the frame probes fully into the ground in line with the cable path while facing the section under test.

**NOTE:** Run the Frame Receiver Cable around the front of the Frame (as shown in Fig. 16) to lengthen cord life.



Fig. 16 — Holding the Earth Contact Frame

- 2) The receiver meter needle will deflect into the meter's green (solid) zone, indicating that the fault is ahead of the operator in the direction of the green-banded leg.
- 3) Continue along the cable path, re-inserting the frame probes every few steps while watching the receiver meter.
- 4) When the needle deflects into the red (striped) arrow, the fault has been passed and is now behind the operator.
- 5) Back up slowly, inserting the frame every few inches until the needle returns to the green zone. The fault will be located beneath the center of the frame when the needle changes from one zone to the other.
- 6) To verify the fault location, rotate the frame, still centered over the fault, 90° to the cable path. Repeat the above procedure to locate the point of meter reversal; this pinpoints the exact location of the fault (see Fig. 17).

**NOTE:** In the case of a high resistance or distant earth fault, the meter needle movement may become very small or even undetectable. However, the meter indication will increase as the operator gets closer to the fault. This is because the gradient signal is highest at the ground rod

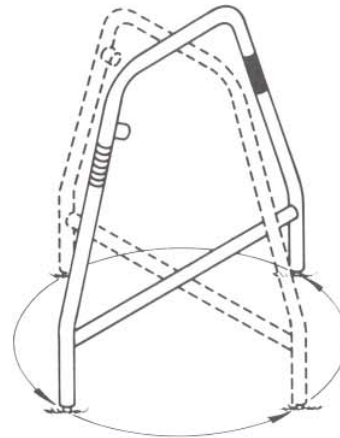

Fig. 17 — 90° Rotation Check

and at the fault, but drops off in between (see Fig. 18). If the meter needle shows no movement or is erratic to the end of the test section, no fault is on the section.

### 3.05 Locating Earth Return Faults Under Pavement

- (a) When the cable is routed beneath and in line with a paved surface, the fault may be located using one of the following methods.

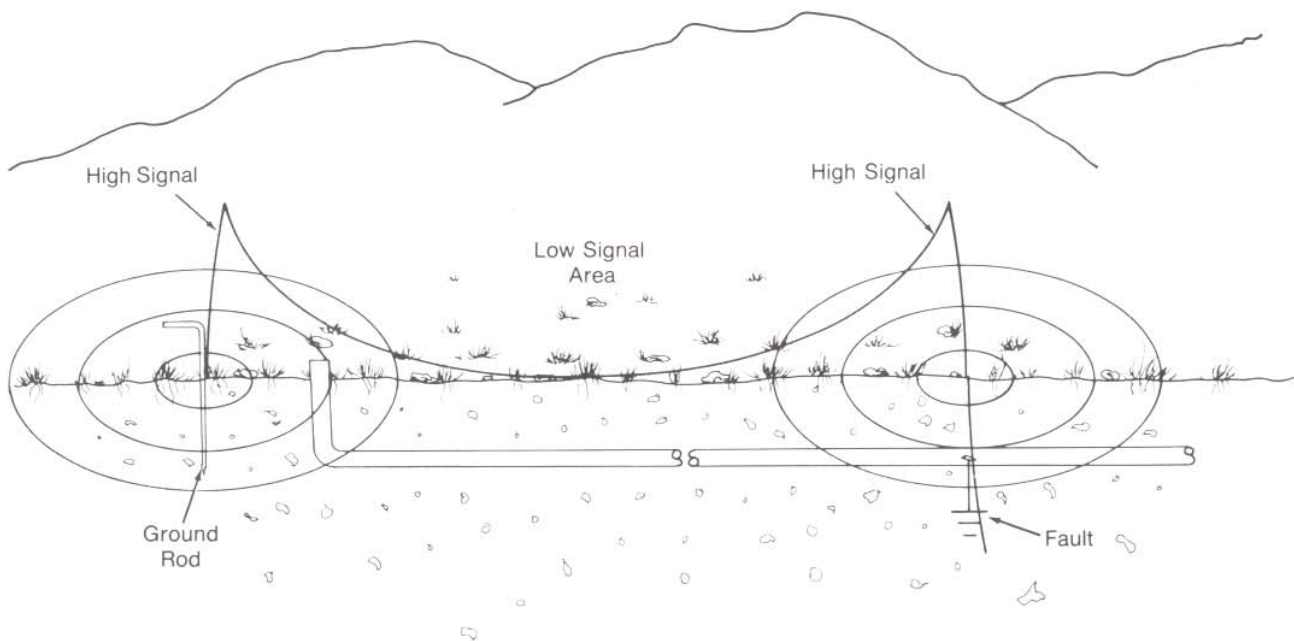

Fig. 18 — Gradient Signal

(b) Perpendicular Method

- 1) Hold the frame parallel to the cable path. Meter reversal will occur when the frame center is directly perpendicular to the sheath fault (see Fig. 19).

(c) Triangulation Method.

- 1) To check the accuracy of a Perpendicular Locate, move back several yards from the

point of meter reversal. Probe in one spot with the frame, rotating it a few degrees between inserts, until the meter reverses with less than one inch of frame movement. A line marked perpendicular to the frame will intersect the cable path at the fault. Repeat this procedure a few yards ahead of the Perpendicular Locate to triangulate and confirm the location (see Fig. 20).

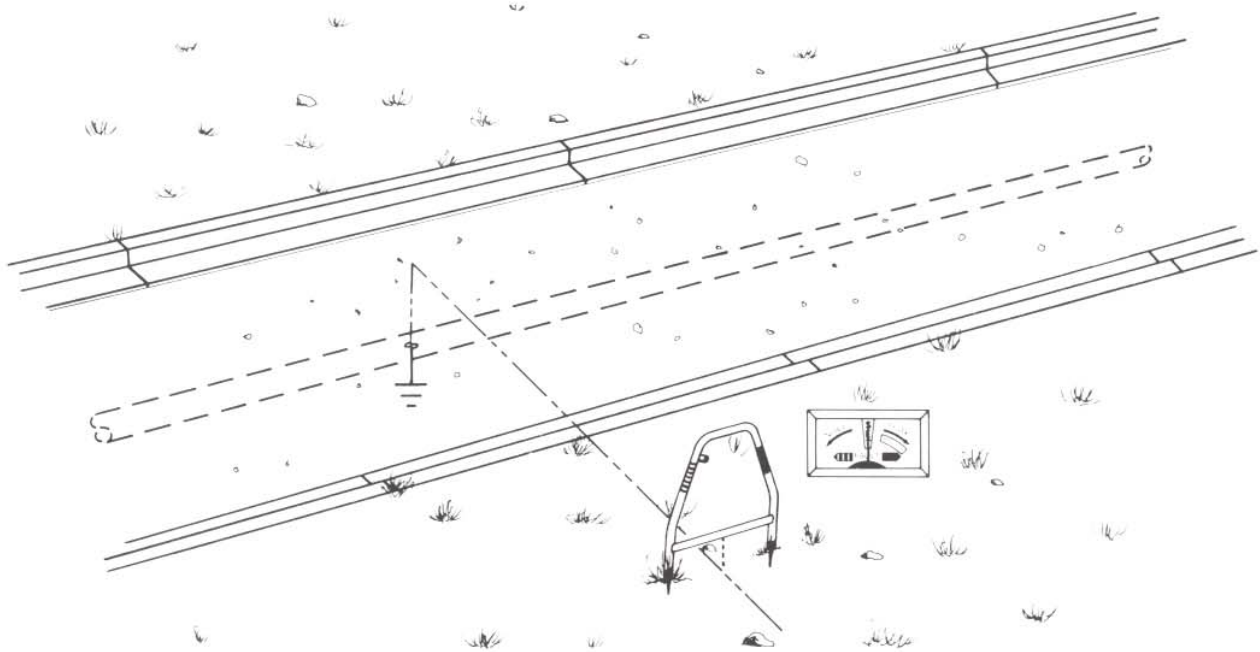

Fig. 19 — Fault Location - Perpendicular Method

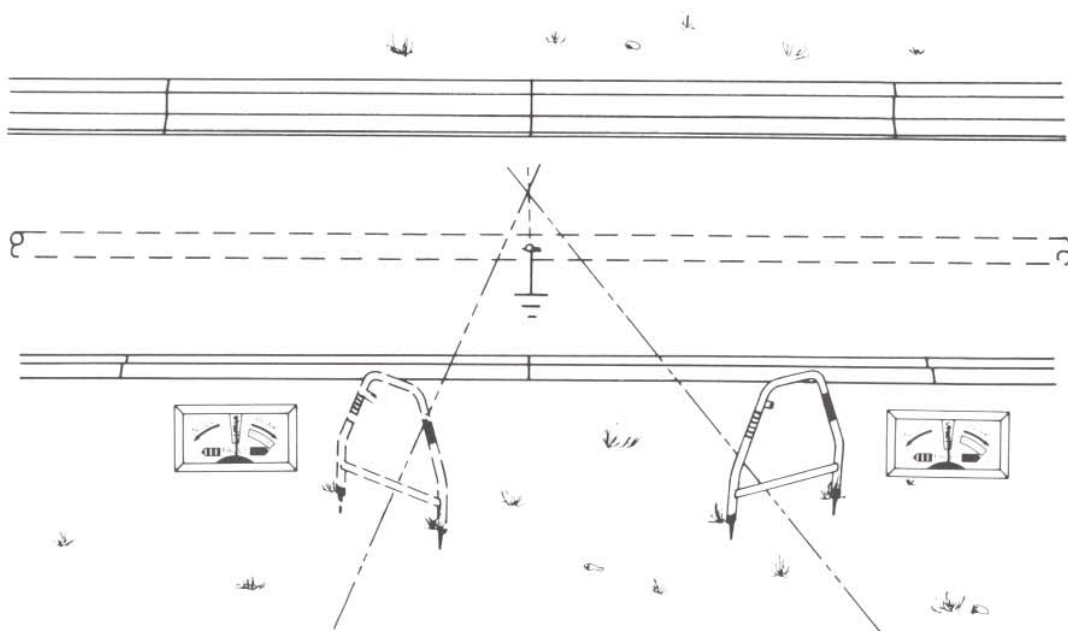

Fig. 20 — Fault Location - Triangulation Method

- (d) If the cable is routed under a large area of asphalt, such as a parking lot, the surface can be penetrated with nails long enough to reach two to three inches into the dirt. The nails can be spaced to accommodate the Earth Contact Frame probes, or may be used with the 9028 Earth Contact Cord (available separately) which is designed for this purpose.
- (e) Extended Frame Method: Where a cable passes under a roadbed or other narrow stretch of pavement, and a check on both sides with the frame proves the fault to be under the roadway, triangulating the fault from both sides of the road will give a general indication of the fault location. A far more accurate method is to extend the breadth of the probes:

- 1) Insert the green probe in earth on the far side of the fault, and hold the red leg clear. Strip about 10 inches of an insulated conductor such as cross-connect wire and take several metallic turns around the red leg. Pull out enough wire to equal twice the width of the road. Strip another ten inches of insulation from the far end and wrap it around a screwdriver. Ground the screwdriver at a point in line with the cable path across the road from the receiver. The screwdriver acts as an extension of the frame's red probe (see Fig. 21).
- 2) Return to the Receiver, making sure the red leg of the frame is held clear of the ground, and note the meter deflection. If the meter deflects to the red (striped) side, the fault is nearest the grounded wire side of the road. If working alone, it will speed the locate to reverse the positions of the frame and the screwdriver at this reading.

- 3) If the needle deflects to the green (solid) side of the meter, move the frame forward along the cable path, probing with the green leg and keeping the red probe clear, until the meter reverses.
- 4) Once the reversal point is established, pull the wire tight between the two contact points. The fault lies exactly half the distance between the green probe and the screwdriver as measured by the tight wire. Fold the wire in half above the cable path for an exact fault location from either probe.

#### 4. Cable Location

4.01 TRACING TONES: The 500A/P or 573A/P TRANSMITTER puts an RF or AUDIO tracing tone on a conductor which is detected and traced by the RECEIVER. In addition, when a cable is energized by AC voltage, the receiver will detect 60 Hz AC current flow without the aid of tone broadcast by the transmitter.

- (a) RF (Radio Frequency) Tone: RF tone is used in most locates. RF transmission is a high frequency tone which provides good accuracy in congested service areas. This mode offers a variety of ways to tone a conductor, and is less susceptible than other frequencies to power and man-made interference. It will not noise-up a circuit and does not require metallic contact or far-end grounding.

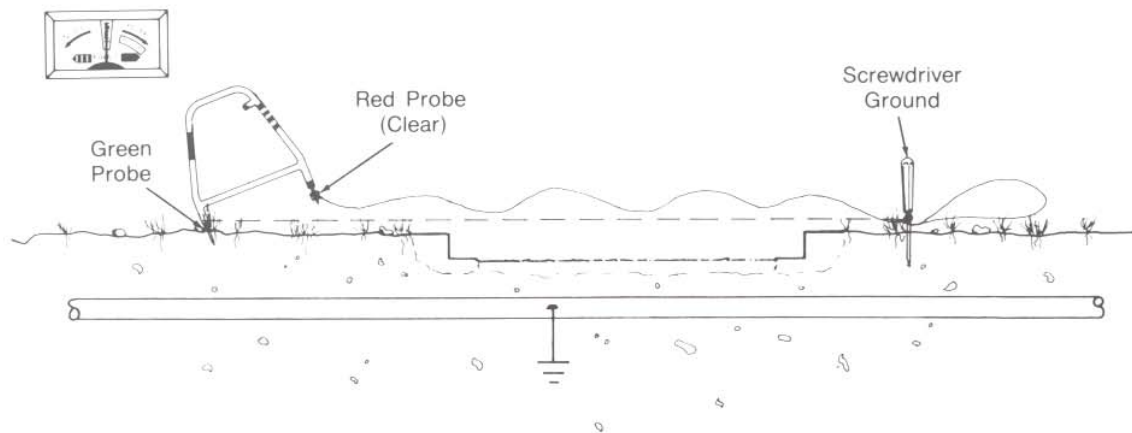

Fig. 21 — Fault Location - Extended Frame Method

- (b) **AUDIO Tone:** AUDIO transmission is a low-frequency tone which carries for long distances in continuously-grounded conductors such as unjacketed concentric neutral, lead or armor-sheathed cable, as well as such other metallic service installations as metal conduit and water or gas pipes. AUDIO tone requires direct connection to a conductor and the far end must be grounded. To check ground integrity:

**500A/P:** Turn TRANSMITTER OUTPUT switch to BAT./FAULT RES. position. The meter needle must be well into the green NORMAL/LOW RES. zone.

**573A/P:** Turn Locate Mode Selector to FAULTMETER. The meter needle must register well into the red FAULT zone.

**NOTE:** AUDIO tone is best used for long traces in relatively uncongested areas. It may be susceptible to other power influences and man-made interference.

- (c) **POWER CABLE.** In POWER CABLE mode the receiver alone detects and traces the magnetic signal of 60 Hz AC current along a conductor. The transmitter is not used in this mode.

**NOTE:** The POWER CABLE setting will detect only current flow. It will not detect potential in a non-working, energized conductor.

4.02 **Transmitter Setup, RF:** The transmitter puts RF tone on a cable in three ways: Direct Connection; Inductive Coupling; General Induction.

- (a) **DIRECT CONNECTION:** This method requires access to the cable neutral or conductor. Plug the 1284 Direct Connect Transmitter Cable into the Transmitter Output Jack at the side of the transmitter.

- (1) Connect the RED clip to the concentric neutral or conductor.
- (2) The transmitter must be sitting on the ground or, if a stronger tone is required, ground the set directly with the BLACK clip attached to the ground rod. Set the ground rod in good soil several feet off, and perpendicular to, the cable path.

**NOTE:** Never ground to water pipe or other services in the area as returning signal may create an out-of-phase condition which will mislead the locate.

- (b) **INDUCTIVE RF COUPLING.** The Dyna-Coupler (Fig. 22) puts tone selectively on a cable by simply clamping around it. This eliminates the need to disconnect bonds or make direct connection to a conductor, but it does require access to the cable.



Fig. 22—The 3001 Dyna-Coupler®

- (1) Connect the 9011 Extension Cable between the coupler and the Transmitter Output Jack. Clamp the coupler around the cable. There is no minimum conductor size, but the jaws of the coupler must fully close for good tone transmission.

**WARNING:** A potential for electrical shock exists when using on cables energized with electrical power. Use appropriate safety procedures.

**DO NOT USE ON CABLES CARRYING IN EXCESS OF 600 VOLTS RMS.**

**NOTE:** Do not use the Dyna-Coupler on a cable that is clear at both ends.

- (c) **GENERAL INDUCTION:** General Induction broadcasts tone generally into an area. No access to the cable is necessary. Set the transmitter on the ground over the cable with transmitter case handle parallel to the cable path. This method should only be used when there are no other conductors present, or when all conductive buried services are to be located in a general area.

**NOTE (1):** Do not use the receiver within 50 feet of the transmitter as tone will be received through the air and mislead the locate.

**NOTE (2):** Be certain that the transmitter is directly over the cable to be located. Leave the receiver on the ground near the cable some 50 feet from the transmitter. Move the transmitter back and forth across the path and listen for a NULL from the receiver.

**NOTE (3):** If other cables or services (such as Telephone Plant, CATV, gas or water pipes, etc.) are in the same area, access to the cable must be found and direct connection or inductive coupling must be used.

4.03 Transmitter Setup, AUDIO Frequency

- (a) AUDIO tone requires direct connection to the concentric neutral or conductor. The cable section should be isolated at both ends, and the traced conductor grounded at the far end.
  - 1) Plug the 1284 Direct Connect Transmitter Cable into the Transmitter Output Jack and attach the RED clip to the conductor or concentric neutral.
  - 2) Connect the 9043 Ground Extension cable to the black clip and attach to the ground rod at least 15 to 20 feet from the set and directly perpendicular to the cable path. If necessary, the ground lead can be extended with any insulated wire.

**500A/P:** Turn the TRANSMITTER OUTPUT switch to BAT./FAULT RES. The meter needle must read well into the green zone. If the needle fails to register in the green zone, check the far-end ground. Turn the selector to AUDIO LOW, 1, 2, 3, HIGH in order and use the setting which deflects the meter needle farthest to the right.

**573A/P:** Turn the Locate Mode selector to FAULTMETER. The meter needle must register well into the red FAULT zone. If the needle falls in the white or green zone, check the far-end ground. Turn the OUTPUT LEVEL to AUDIO 1, 2, 3, 4, and 5 in order. Use the setting which deflects the meter needle farthest to the right.

4.04 RECEIVER MODE Selection:

- (a) RF TONE: With the TONE SELECT switch at RF, turn the RECEIVER MODE switch to NULL or PEAK. (See Par. 4.07 [a] and [b]).
- (b) AUDIO TONE: With the TONE SELECT switch to AUDIO, set the RECEIVER MODE switch to NULL or PEAK. (See Par. 4.07 [a] and [b]).
- (c) POWER CABLE: No transmitter is needed for this method. Turn TONE SELECT to POWER CABLE and locate in PEAK or NULL (See Par. 4.07 [a] and [b]). The cable to be located must be carrying a 60 Hz AC current. Tone strength may vary and the receiver sensitivity should be continually adjusted to keep the needle in the normal range. **WARNING:** Power cable that is energized but not delivering power will not be detected.

**NOTE:** Because of the complex electrical fields, POWER CABLE locates may not be as definite as those with transmitted tone.

4.05 The Receiver Signal Level meter indicates the strength of the tone being received. Needle deflects to the right for strong tone (PEAK); needle deflects to the left for weak or canceled tone (NULL). The yellow center zone (SET) is for cable depth finding (SET mode). The BAT OK zone is used for battery testing. The red (striped) and green (solid) FAULT arrows are used in sheath fault locating (see Sec. 3).

4.06 The Sensitivity Control Knob adjusts both meter sensitivity and speaker volume. As the cable is traced, adjust the control knob as required so that the meter is not overdriven (See Par. 4.07).

4.07 Receiver Mode Selection: NULL and PEAK

- (a) NULL (Fig. 23): In this mode, tone picked up by the receiving coil cancels when it is directly over the cable. The meter needle deflects to the "Null" area and the speaker falls silent. As the receiver moves past the cable midpoint, the audio tone increases and the needle will return to the right. NULL gives a more precise center point than PEAK, but is more apt to be misled by foreign conductors in the area. Swing the receiver across the suspected cable path with a sweeping motion. In NULL, the point of minimum needle deflection and tone is the cable path.

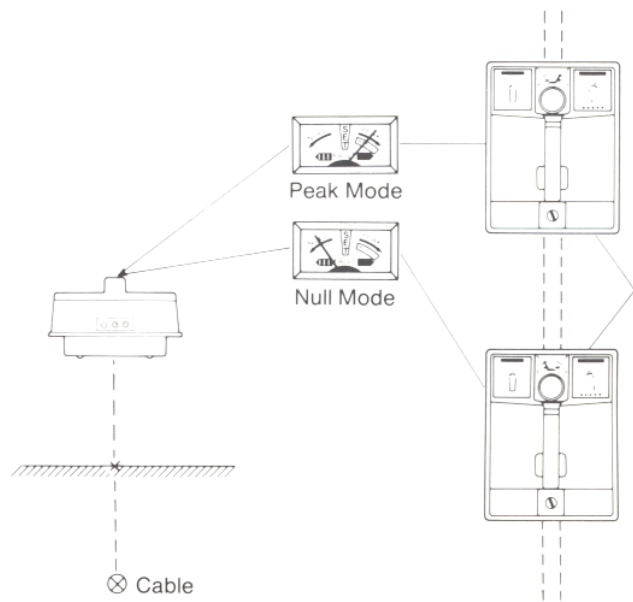

Fig. 23 — Signal Indications PEAK and NULL Modes



(b) **PEAK** (Fig. 23): In this mode, tone increases to a maximum as the cable is passed, and then diminishes as the receiver moves further off the cable path. The meter needle will deflect to the "Peak" zone and then return as the midpoint is passed. "Peak" is less sensitive than "Null" but allows speed in uncomplicated locates and it is more reliable when tracing changes in cable direction as tone falls off rapidly if the handle is not in line with the cable path. In such a case, a sharp turn or bend in the path is indicated.

- (1) Use the sensitivity Control Knob to adjust reception on PEAK for meter needle action in the mid-scale area. Adjusting gain for a hard meter overdrive will confuse the locate.

**NOTE:** Each locating mode has its advantage. To assure maximum accuracy, and to eliminate any doubts about a locate, check the trace in both PEAK and NULL modes. If still in doubt, expose the cable.

## 5. Determining Cable Depth

### 5.01 Direct Measurement

(a) Using RF or AUDIO transmitted tone, locate and mark the exact cable path. To determine depth:

- 1) Place the receiver on the ground directly above the cable, with the handle parallel to the path (see Fig. 24).

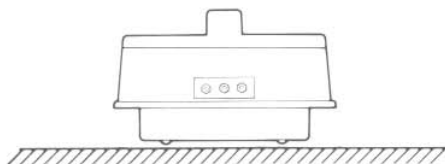

⊗ Cable

- 2) Turn the RECEIVER MODE selector to SET. Adjust the VOLUME control so that the meter needle is centered in the yellow area labeled SET.
- 3) Turn the RECEIVER MODE switch to PEAK. Note that the meter reading and the loudspeaker tone both increase.
- 4) Raise the receiver straight up from the ground until the meter needle returns to the SET area of the meter.
- 5) Measure the distance from the bottom of the receiver to the ground. This distance is equal to the depth of the cable below the surface at this point (see Fig. 24).

**NOTE:** The POWER CABLE reception mode may be used to measure depth on conductors with 60 Hz AC current. However, the measurement accuracy may be affected by other power conductors in the area—including overhead lines.

### 5.02 Triangulation Method

(a) As Direct Measurement is limited by the height the operator can hold the receiver, the triangulation method may be used to measure the depth of deeply buried cable. Using either RF or Audio transmission, determine the exact cable path. To measure depth:

- 1) With the receiver in NULL mode, mark a point on the cable path (Fig. 25 [1]).

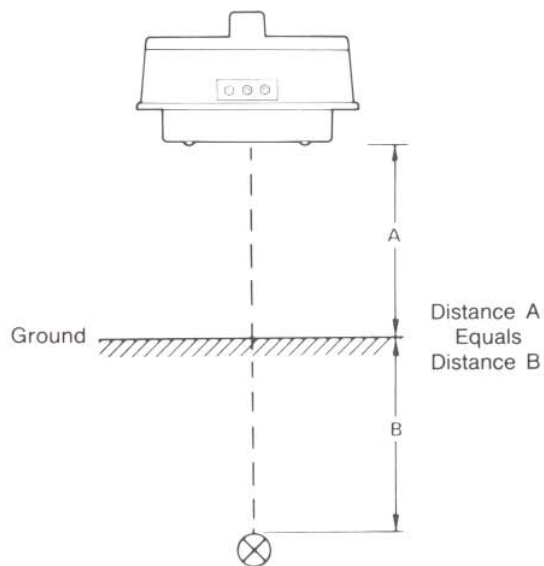
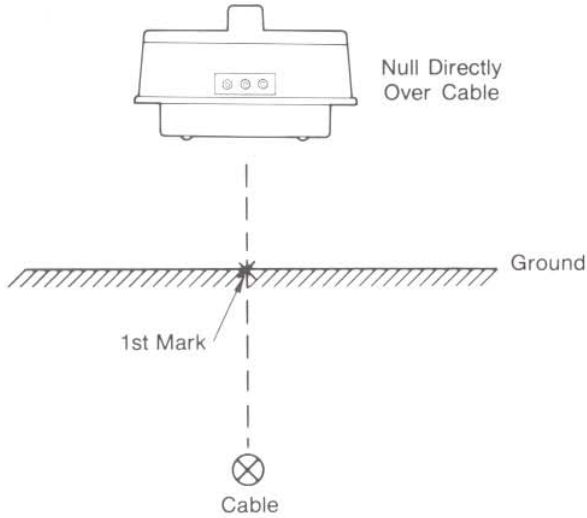

Fig. 24 — Determining Cable Depth - Direct Measurement

- 1) First This...  
Set Receiver Mode To Null.



- 2) Then This...

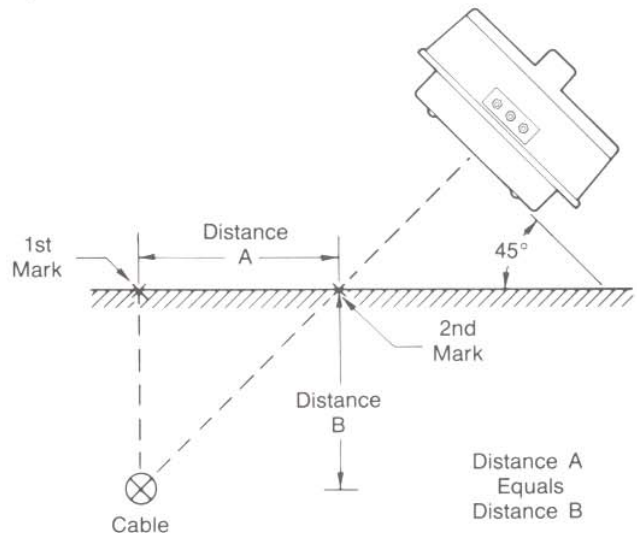

Fig. 25 — Determining Cable Depth - Triangulation

- 2) Hold the receiver so the handle is parallel to the cable path and tilt it so the bottom is at a  $45^\circ$  angle relative to the ground (Fig. 25 [2]).
- 3) Maintaining the receiver angle, move to the side of, and perpendicular to, the cable path until the receiver again indicates a NULL.
- 4) Mark the ground at the point a perpendicular line would project from the bottom of the angled receiver.
- 5) The distance between the first mark and the second mark equals the depth of the cable below the first mark.

**NOTE:** The accuracy of this measurement is dependent upon the accuracy of the  $45^\circ$  angle at which the receiver is held. For best results, hold the receiver close to the ground while performing this measurement.

## 6. Special Applications

### 6.01 Identifying Cables with RF Tone

- (a) This procedure will identify a single cable in a group of similar cables and distinguish common—bussed cables.

- 1) At an access where cable identity is known, put tone on the sought cable with Direct Connection or with an extra Dyna-Coupler.



Fig. 26 — Receiver Setup for Cable Identification with a Dyna-Coupler®

- 3) Set the RECEIVER MODE selector to:

500A/P: EXT  
573A/P: PEAK (EXT)

Adjust the meter needle to about half-scale deflection. Do not overdrive the receiver.

- 4) Check each cable in the group. The cable with a significantly higher reading than the others is the one being sought.

#### 6.02 Identifying a Cable with AUDIO Tone

- (a) This procedure will identify a single cable in a group of similar cables or distinguish common-bussed cables.

- 1) At an access where the cable is known, ground a conductor.
- 2) At a far-end access where cable is known, connect the 573A transmitter to the conductor and ground.

**500A/P:** Turn the TRANSMITTER OUTPUT switch to BAT./FAULT RES. The meter needle must read well into the green zone. If the needle fails to register in the green, check the far-end ground. Turn the selector to AUDIO LOW, 1, 2, 3, HIGH in order and use the setting which deflects the meter needle farthest to the right.

**573A/P:** Turn the Locate Mode selector to FAULTMETER. The meter needle must register well into the red FAULT zone. If the needle falls in the white or green zone, check the far-end ground. Turn the OUTPUT LEVEL to AUDIO 1, 2, 3, 4, and 5 in order. Use the setting which deflects the meter needle farthest to the right.

- 3) Move to the access where cable identity is unknown. Connect an exploring coil to the TONE COIL jack of the receiver and select AUDIO on the TONE SELECT switch and PEAK (EXT) on the RECEIVER MODE selector.
- 4) Test each cable in the access with the exploring coil. The sought cable will be the only one with tone on it.

#### 6.03 Identifying a Cable using POWER method

- (a) If the cable to be identified is the **only** working power cable in the cable group, this procedure will identify it.
  - 1) At the end where the cable is unknown and needs to be identified, connect an exploring coil to the receiver TONE COIL jack.

- 2) Set the RECEIVER MODE selector to:

500A/P: EXT  
573A/P: PEAK (EXT)

Adjust the meter needle to about half-scale deflection. Do not overdrive the receiver.

- 3) Check each cable in the group. The cable with a significantly higher reading than the others is the one being sought.

#### 6.04 Slack-Loops and T-Splices, RF and AUDIO

- (a) To identify the presence of a Slack-Loop or T-Splice in a cable path, first locate and mark the cable path using RF or AUDIO tone. Retrace the path in the following manner:

- 1) Set the RECEIVER MODE selector to:

500A/C: PEAK  
573A/C: PEAK (EXT)

- 2) Hold the receiver so the handle is PERPENDICULAR (across) the cable path and the tone from the receiver is minimum (Fig. 27).

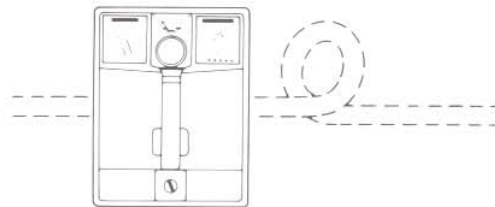

Fig. 27 — Identifying a Slack Loop or T-Splice

- 3) Retrace the cable path with the receiver held in this manner. When the receiver passes over a slack loop or T-Splice, the tone will increase and the meter needle will deflect to "Peak". This indicates a sudden change in signal caused by a turn or "wow" in the cable path.

**NOTE:** The receiver will sense loops and T-splices only if the handle is held perpendicular to the cable path. When the handle is held parallel to the path, tracing tone is constant and such underground configurations will not be apparent.

- 4) Mark each occurrence of increased tone. Whenever such a condition is encountered, it should be checked to see if an unknown lateral exists (see Par. 6.05, page 18).

## 6.05 Unknown Laterals—RF and AUDIO

(a) To check for unknown laterals from a closure, first mark the cable path and then retrace marking any T-splices or slack loops as in paragraph 6.04 (above).

1) Switch the receiver to:

500A/C: PEAK

573A/C: PEAK (EXT)

mode and walk 10 to 25 feet off the path, away from the mark (Fig. 28). Hold the receiver so that the meter end of the handle points directly AWAY from the mark. Walk in a circle around the mark with the receiver always pointing outward.

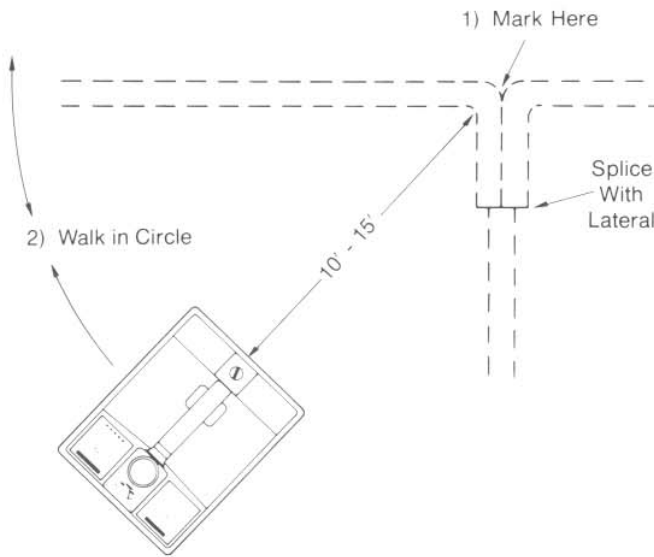

Fig. 28 — Locating Laterals

2) The receiver will remain relatively quiet until it crosses a lateral (or the actual cable path.) Tone will PEAK at its loudest when directly over a lateral. As there may be several laterals radiating from the closure, mark each occurrence of tone around the cable. After each lateral is located, its path may be traced and marked.

## 6.06 Locating Cables from Pedestals or Accessible Closures

(a) Put tracing tone on the cable or conductor either Directly (RF or AUDIO) or with the Dyna-Coupler (RF tone only).

**NOTE:** When using RF tone and the Dyna-Coupler, be sure to place the coupler between the common bond and the point where the cable goes underground. The bond actually backstops the tone and directs it down the cable.

- 1) Switch the receiver to PEAK mode and walk 10 to 25 feet away from the access. Hold the receiver so that the meter end of the handle points directly AWAY from the pedestal or closure. Circle with the receiver always pointing outward.
- 2) The receiver will remain relatively quiet until it crosses a cable. Directly over the cable to which tone is attached, the tone will be at its loudest. As there may be several cables radiating from the closure, mark each occurrence all the way around the circle. After each cable is located, tone may be applied and its path may be traced and marked.

## 6.07 Service Drop Location

(a) When locating the path of a service drop from a house or other building, use RF tone and standard cable location procedures. It may be most convenient to use a direct connection to the drop at the meter.

- 1) Connect the RED clip of the transmitter output cable to the meter and place the transmitter on the ground (or use the BLACK clip to the ground rod).
- 2) Locate the cable using standard NULL or PEAK mode and the techniques outlined in Section 4.

## 6.08 Locating a Clear or Severed End

(a) This procedure locates the unterminated or open end of a cable or drop. Normally, it can only be performed in the RF tone mode, but if the severed end of the cable is grounded, AUDIO Signal may be used and the fault pinpointed with the earth contact frame.

- 1) If the cable is bonded or connected at one end, use the Dyna-Coupler to put RF tone on ungrounded cable. Attach the coupler between the bonding or connecting point and the point where the cable goes underground.
- 2) Use Direct Connection for AUDIO tone if the cable is grounded at the far end, or for RF tone if the cable is clear at both ends.

- 3) Set the Receiver to PEAK and trace the cable path. The tone will decrease suddenly at the site of the clear or severed end. The earth contact frame will pinpoint the site if the end is grounded.

#### 6.09 Cable Connection Tips

- (a) RISERS. When locating a cable going underground from a riser, use RF tone and the Dyna-Coupler. Reach above the U-guard, pull the cable away from the pole and attach the coupler around the cable. The path of the cable can now be traced.

7. **Care and Maintenance:** Operator maintenance of the 500A/P and 573A/P sets are limited to battery replacement and minor care.

#### 7.01 Battery Tests

- (a) 500A/P TRANSMITTER: The TRANSMITTER OUTPUT selector has a momentary-contact BAT./FAULT RES. battery test position. To check battery condition:
  - 1) Plug in the 1284 Direct Connect Transmitter Cable and short the red and black clips.
  - 2) Hold the TRANSMITTER OUTPUT selector to BAT./FAULT RES. for 5 to 10 seconds. A meter indication in the BAT. OK section indicates acceptable battery condition.
- (b) 573A/P TRANSMITTER: The OUTPUT LEVEL selector has a momentary-contact BAT./TEST battery test position. To check battery condition:
  - 1) Hold the Transmitter OUTPUT LEVEL switch fully counter-clockwise for 5 to 10 seconds. The batteries are good if the meter needle remains in the "Bat OK" section of the meter. As the batteries age, the meter needle will not deflect as far into the "OK" range. When the needle is at the low end of the scale, replace the Batteries.
- (c) 500A/P and 573A/P RECEIVERS:
  - 1) Remove the receiver from the transmitter case and hold the RECEIVER MODE selector fully counter-clockwise to BATT for 5 to 10 seconds. The meter should indicate "Bat OK". If not, replace the batteries.

#### 7.02 Battery Replacement

- (a) TRANSMITTER: The transmitter uses four standard 6-volt carbon-zinc lantern cells. See Table A for replacement types. To change the batteries, use the following procedure:
  - 1) For access to the transmitter battery compartment, take the receiver out of the transmitter. The batteries are located in the bottom of the carrying case, beneath a plastic storage tray. Remove the four screw fasteners and lift out the storage tray. Remove the battery cover clamp and cover.
  - 2) Disconnect each battery, lift from case and replace with a fresh battery. Place new batteries in the same position as the old batteries. Attach the wiring as indicated in Fig. 29.

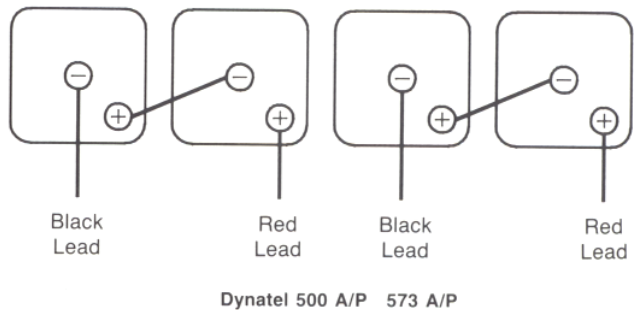

Fig. 29— Transmitter Battery Hookup

**NOTE:** The transmitter has a protection circuit that prevents damage if the leads are connected incorrectly. **HOWEVER, THE TRANSMITTER WILL NOT OPERATE IN THIS CONDITION.**

- 3) After the batteries have been changed, verify correct connections by repeating battery test procedure. Replace the cover, clamp and storage tray and tighten the screw fasteners.
- (b) RECEIVER: The receiver uses four 9-volt carbon-zinc transistor batteries located under the access cover at the end opposite the controls. See Table A for replacement types. To change the batteries, use the following procedure:

- 1) Remove the access cover and replace all batteries. Retest.
- 2) Replace access cover and tighten the cover screw.

7.03 Battery Life: Battery life should exceed 100 hours of use under average field conditions.

7.04 FUSES

- (a) Testing and replacing the transmitter fuses:
  - 1) Insert the Direct Connection Cable into the transmitter output jack.
  - 2) Hold the fuse between the red and black clips. Set the transmitter selector to BAT./ FAULT RES. (500A/P) or FAULT METER (573A/P). The meter needle should deflect into the red FAULT zone to show low resistance. If not, the fuse is open and must be replaced.

7.05 Available Connection Cables and Accessories (Fig. 30)

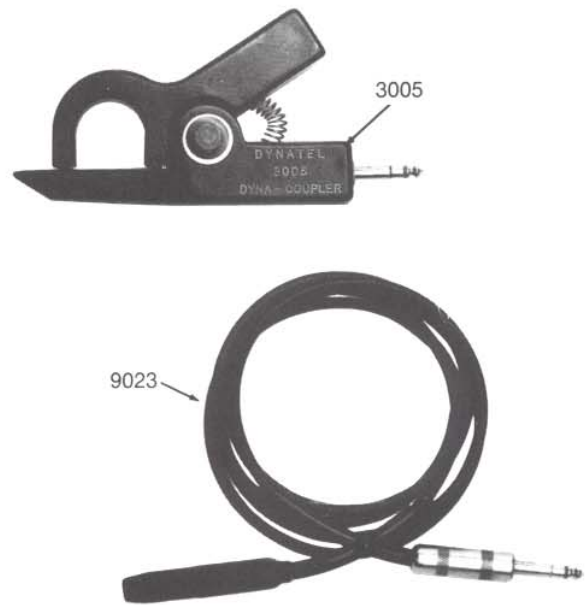

Fig. 30 — Accessories

8. Returns

8.01 All items returned to 3M Dynatel Systems must be accompanied by a Material Return Authorization (MRA) number, which may be obtained by contacting the 3M Dynatel Systems Repair Department, as specified below, that services your particular product. After receiving an MRA number, the equipment should be shipped prepaid to:

All Products:

3M Dynatel Systems Division  
**Attn:** Repair Department  
 11705 Research Blvd.  
 Austin, Texas 78759  
 512/258 1651 or 800/531 5308  
 TWX 910 874 2020

All Dynatel® Products and APC Construction Products:

3M Dynatel Systems Division  
**Attn:** Repair Department  
 6600 Jimmy Carter Blvd.  
 Norcross, Georgia 30071  
 404/447 7145

All Dynatel® Products

3M Dynatel Systems Division  
**Attn:** Repair Department  
 420 N. Bernardo Ave.  
 Mountain View, California 94043  
 415/969 5200

**TABLE A**  
 Battery Types

UNIT	No. of Batteries	Voltage	NEDA	Eveready	Burgess	Ray-O-Vac
Transmitter	4	6V	915	510S	F4BP	954
Receiver	4	9V	1064D	1222	2MN6	D-1604*

\* Long life

NOTE: Both shipping carton and packing list must reference the MRA number.

8.02 Enclosed with the equipment should be a statement giving the reason for return as well as the name, address and telephone number of the person to whom the unit is to be returned and billed.

**9. Repairs**

9.01 **WARRANTY ON REPAIRED EQUIPMENT:** All repair of 3M Dynatel Systems instruments, except the APC Models 1301 and 1303, are warranted to be free from defects in material and workmanship for a period of ninety (90) days, commencing on the date of shipment to the buyer. APC Models

1301, 1303 and all other 3M Dynatel Systems product repairs are warranted for thirty (30) days. 3M Dynatel Systems sole and exclusive obligations and liabilities under these warranties are and shall be limited to issuance of credit for or repair or replacement of any goods or parts which are proved to be other than as warranted; and 3M Dynatel Systems shall have sole discretion as to which of these remedies it shall provide. 3M Dynatel Systems shall not reimburse or make any allowance to buyer for any labor or freight charges incurred.

9.02 **ON-SITE REPAIR:** On-site repair service is available for the APC Model 1301 only. Contact 3M Dynatel Systems in Austin, Texas for specific charges.

Dynatel<sup>®</sup> and Dyna-Coupler<sup>®</sup> are registered trademarks of 3M.

Patent-Pending

**Important Notice to Purchaser:**

All statements, technical information and recommendations contained herein are based on tests we believe to be reliable, but the accuracy or completeness thereof is not guaranteed, and the following is made in lieu of all warranties expressed or implied:  
Seller's and manufacturer's only

obligation shall be to replace such quantity of the product proved to be defective. Neither seller nor manufacturer shall be liable for any injury, loss or damage, direct or consequential, arising out of the use of or the inability to use the product. Before using, user shall determine the suitability

of the product for his intended use, and user assumes all risk and liability whatsoever in connection therewith. No statement or recommendation not contained herein shall have any force or effect unless in an agreement signed by officers of seller and manufacturer.

1000-0750-801-D  
80-6105-4036-3

©1988 Minnesota Mining and Manufacturing Company

Litho in U.S.A. with 3M film, plates and chemicals

**3M Dynatel Systems Division**

PO Box 2963  
Austin, TX 78769 2963

**3M**