

### Model 2272 Piezoelectric accelerometer

#### Features

- Long term stability
- Hermetically sealed
- Operational to -452°F [-269°C]
- Requires no external power
- Vibration measurement at extreme temperature



#### Description

The Endevco® model 2272 is a piezoelectric accelerometer designed specifically for vibration measurement at temperature extremes. The unit is hermetically sealed for use in harsh environments and features long term stability. Its unique sensing elements offer an unusually flat temperature response over a broad range. The accelerometer is a self-generating device that requires no external power source for operation.

The model 2272 features Endevco's Piezite® type P-10 crystal element, operating in compression mode. This unit exhibits excellent output sensitivity stability over time. Signal ground is connected to the outer case of the unit. When used with an isolated mounting stud, the accelerometer is electrically isolated from ground. The accelerometer features a 10-32 UNF-2A side-connector. A low-noise coaxial cable is supplied for error-free operation.

Endevco signal conditioner models 133, 2775B, 2771C, 6634C or Oasis 2000 computer-controlled 4990A-X system are recommended for use with this high impedance accelerometer with cards 428 and/or 433.

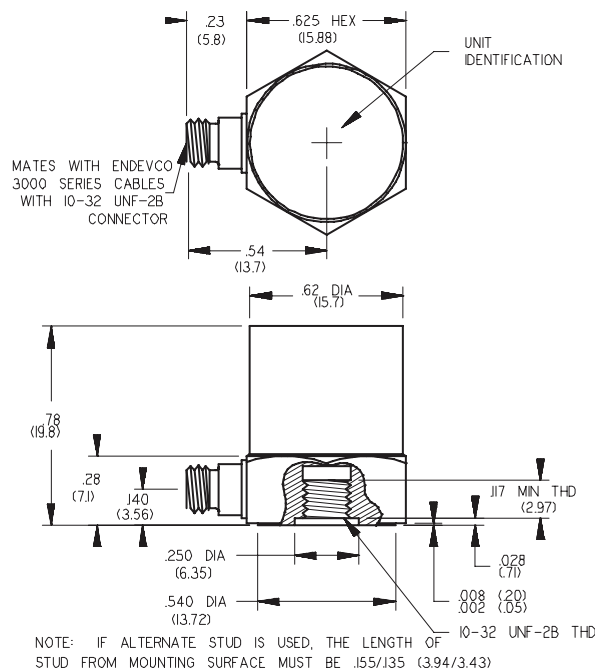

STANDARD TOLERANCE  
INCHES (MILLIMETERS)  
.XX = +/- .03 (X = +/- .8)  
.XXX = +/- .010 (XX = +/- .25)

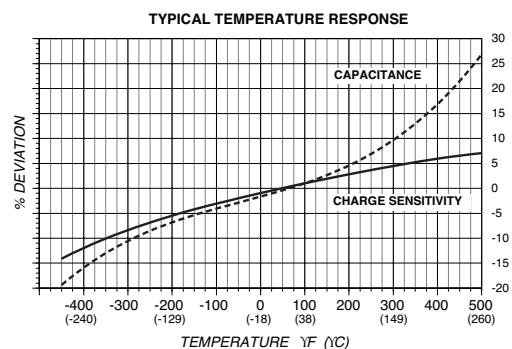
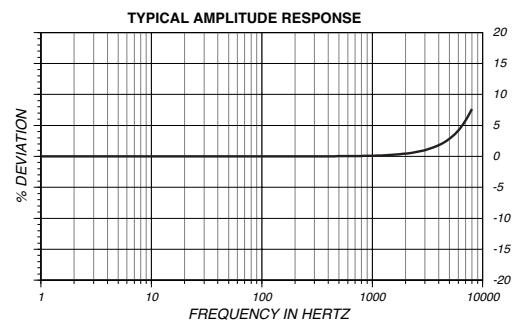

# Model 2272 Piezoelectric accelerometer

# Endevco

## Specifications

The following performance specifications conform to ISA-RP-37.2 (1964) and are typical values, referenced at +75°F (+24°C) and 100 Hz, unless otherwise noted. Calibration data, traceable to National Institute of Standards and Technology (NIST), is supplied.

### Dynamic characteristics

	Units	2272
<b>Charge sensitivity</b>		
Typical	pC/g	13
Minimum	pC/g	10.4
<b>Frequency response</b>		
Resonance frequency, typical	kHz	See typical amplitude response
Minimum	kHz	30
<b>Amplitude response [1]</b>		
±5%	Hz	1 to 5000
±1dB (ref.)	Hz	1 to 9000
<b>Temperature response [3]</b>		
Transverse sensitivity	%	See typical curve
Amplitude linearity		≤ 3
Per 1000 g, 0 to 2000 g	%	1

### Electrical characteristics

Output polarity		Acceleration directed into the base of the unit produces positive output
Resistance	GΩ	≥ 10
at +500°F (+260°C)	MΩ	≥ 100
Capacitance	pF	2700
Grounding		Signal ground connected to case

### Environmental characteristics

Temperature range		-452°F to +500°F [-269°C to +260°C]
Humidity		Hermetically sealed
Sinusoidal vibration	g pk	1000
Shock limit [2]	g pk	2000
Base strain sensitivity	equiv. g pk/μ strain	0.04
Thermal transient sensitivity	equiv. g pk/°F [1/°C]	0.08 (0.144)
Electromagnetic sensitivity	equiv. g rms/gauss	0.0002
Acoustic sensitivity at 140 dB SPL	equiv. g	0.001
at 170 dB SPL	equiv. g	0.03
<b>Pressure</b>		
Low frequency up to 1000 Hz	equiv. g/psi	0.01
Salt spray		Will meet MIL-E-5272 with potted connector

### Physical characteristics

Dimensions		See outline drawing
Weight	oz (gm)	0.95 (27)
Case material		Stainless steel
Connector		10-32 UNF-2A Thd, mates with Endevco 3000 series cable
Mounting torque	lbf-in (Nm)	18 (2)

### Calibration

Supplied:		
Charge sensitivity	pC/g	
Capacitance	pF	
Maximum transverse sensitivity	%	
Charge frequency response	%	20 Hz to 5000 Hz
	dB	5000 Hz thru resonance

### Accessories:

Product	Description	2272
92981-12	Mounting stud, 10-32, Hex I.D.	Included
3090DV-120	Cable assembly, 10 ft	Included
EHM464	Wrench, hex key	Included
2981-3	Stud, 10-32 adapter	Optional
133	Signal conditioner	Optional
2771C	In-line charge convertor IEPE powered	Optional
2775B	Signal conditioner	Optional
6634C	Signal conditioner	Optional
4990A-X	OASIS 2000 computer-controlled system with 428 and/or 433	Optional
CS330	Calibration cryogenic temperature response	Optional

### Notes:

- Low-end response of the transducer is a function of its associated electronics.
- Short duration shock pulses, such as those generated by metal-to-metal impacts, may excite transducer resonance and cause linearity errors. Request the TP290 for more details.
- Exposure to rapid temperature changes greater than 100°F (38°C) per minute may cause the device to produce spurious high frequency discharges for several minutes.
- Maintain high levels of precision and accuracy using Endevco's factory calibration services. Call Endevco's inside sales force at 800-982-6732 for recommended intervals, pricing and turnaround time for these services as well as for quotations on our standard products.



Continued product improvement necessitates that Endevco reserve the right to modify these specifications without notice. Endevco maintains a program of constant surveillance over all products to ensure a high level of reliability. This program includes attention to reliability factors during product design, the support of stringent Quality Control requirements, and compulsory corrective action procedures. These measures, together with conservative specifications have made the name Endevco synonymous with reliability.

©ENDEVCO CORPORATION. ALL RIGHTS RESERVED 30700 RANCHO VIEJO ROAD, SAN JUAN CAPISTRANO, CA92675 USA  
(800) 982-6732 • (949) 493-8181 fax (949) 661-7231 • www.endevco.com • Email: applications@endevco.com

080510

**MEGGITT**  
smart engineering for  
extreme environments