

ATS-635 THERMOSTREAM®

DATASHEET AND SPECIFICATIONS

-60° to +225°C



Designed for **60Hz operation**, this Advanced Temperature Source is for fast and precise thermal conditioning of components, parts, hybrids, modules, subassemblies, and printed circuit boards. Capable of ultra-low temperatures **without** the use of Liquid Nitrogen (LN₂), Liquid Carbon Dioxide (LCO₂), or compressed air.

PERFORMANCE:

Temperature Range*

-60 to +225°C

No LN₂ or LCO₂ Required

Transition Rate*

-40 to +125°C, <12 seconds

+125 to -40°C, <40 seconds

System Airflow Output*

5scfm (2.4 l/s) Fixed Flow Rate

*Under nominal operating conditions.

TEMPERATURE CONTROL:

Temperature Display & Resolution

+/- 0.1°C

Temperature Accuracy

1.0°C (when calibrated against NIST standard)

DUT Temperature Control

proprietary control algorithm enables DUT temperature to be directly controlled

DUT Sensor Ports

thermocouples: type T & K

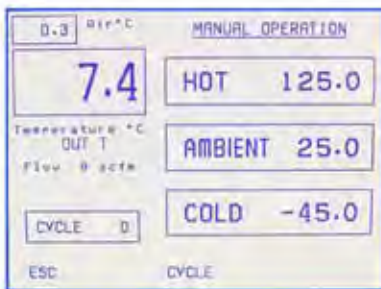

OPERATOR SCREEN

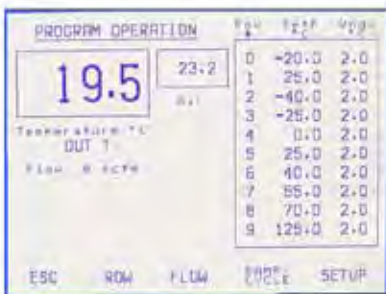

PROGRAM SCREEN

FEATURES:

▶ Frost Free Feature

dry air purge for tester interface, prevents condensation: 0.5 to 3scfm (0.25 to 1.5 l/s)

▶ ECO Friendly Feature

Heat Only Mode

reduces power usage when cold temperatures are not used

▶ Thermal Cap

5.5 inch ID Glass Thermal Cap to enclose your test subject

▶ Fully Adjustable Thermal Head

can be mounted on either side of unit

▶ Internal Air Compressor

supplies clean, dry air to the system without the need for facility air

▶ Local & Remote Operations

▶ LabView™ drivers

▶ IEEE-488, RS232 ports

▶ customizable and savable test setups

▶ Program & Datalog Storage

▶ User Defined Temperature Limits

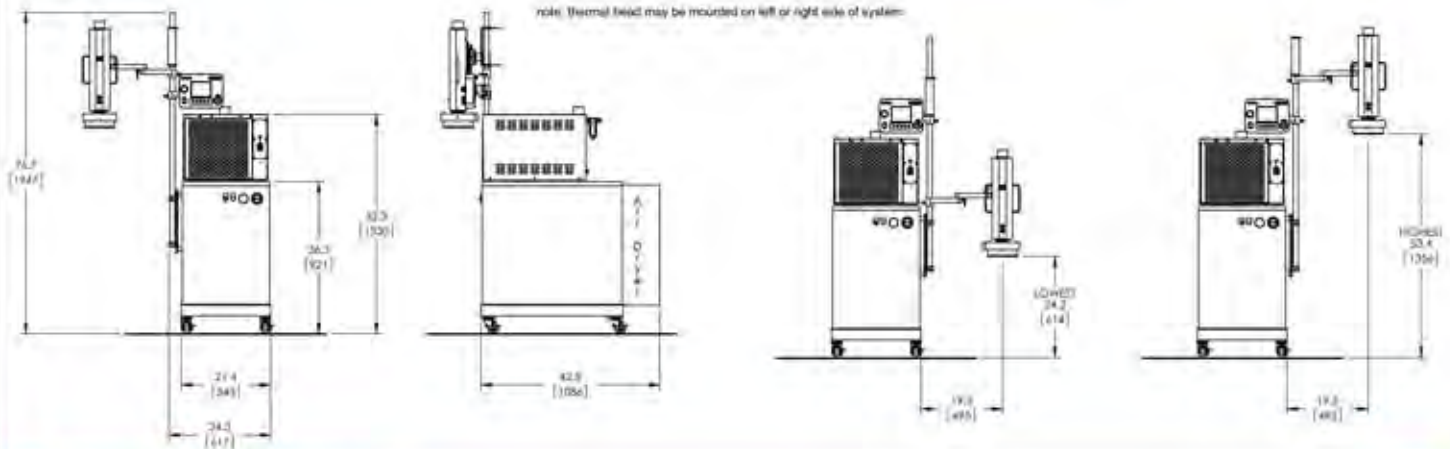

Weights and Dimensions

Dimensions 194.7cm (76.7 inches) X 61.7cm (24.3 inches) X 108.6cm (42.8 inches)

Weight 249.5 Kg (550 lbs.)

Noise Level < 70dBA (< 60dBA with remote compressor upgrade kit, CS210240)

Service and Safety

Refrigerants HCFC and CFC-free, non-toxic, non-flammable
Serviceability Auto-diagnostics and field replaceable modules
Over Temperature Protection +230°C (factory set). Operator can set high and low air temperature limits

Facility Requirements

Power¹
 Chiller Power: 220 ±10% VAC, 60Hz, 16amp
 Compressor Power: 220 ±10% VAC, 60Hz, 30amp

Operating Environment
Operating Temperature +20° to +28°C; +23°C nominal
Humidity 0 to 60%; 45% nominal

¹ System is configured for operation within voltages listed above. Please specify power configuration with order.

inTEST Thermal Solutions
 41 Hampden Road
 Mansfield, MA 02048
 TEL: 1.781.688.2300
 www.inTESTthermal.com
 ISO 9001 Certified

