



DIELECTRIC RELAXATION SPECTROSCOPY WITH KEITHLEY 617 ELECTROMETER

Ing. Tomáš PALAI-DANY, Doctoral Degree Programme (1)
Dept. of Physics, FEEC, BUT
E-mail: xpalai00@stud.feec.vutbr.cz

Supervised by: Dr. Karel Liedermann

ABSTRACT

In this paper is described application of Keithley 617 electrometer in time domain dielectric relaxation spectroscopy measuring. The first chapter refers the basic knowledge for electrical parameters of dielectric materials, following this we are able to explore their features to request use. The second chapter describes the measuring techniques of these parameters in frequency and time domain. Used measuring method of time domain dielectric relaxation spectroscopy is summarized in the third chapter, the next chapter connects experimental measurement on the test dielectric sample and shows its event. In the finish chapter are valorized the features of experimental measurement and designed requirements for test equipment modification.

1 INTRODUCTION

From the theory it's known, that ideal dielectric or insulator is composed by material, which contains bound charges only by electrostatic forces [1], [4]. Real dielectric materials contain except bound charges even some free charges, making its unwelcome electrical conductivity. The physics of dielectrics occupies with running process in materials by electrical field activity, and then mentioned motions of electrical charges. In dielectrics usually designed for capacitors the basic physics process is dielectric polarization, which are effects combined with free motion of bound charges. In real dielectrics we must actually consider with electrical conductivity and combined effects with free charge motion. The electrical properties depend on chemical structure, state and stage of dielectric material. The basic electrical variables to establish dielectric features in electrical field over specific temperature and frequency are:

Relative permittivity ϵ' (-)

Internal resistivity ρ_v (Ωm)

Surface resistivity ρ_p (Ω)

Loss factor $\text{tg}\delta$ (-)

Disruptive strength E_p (Vm^{-1}).

Dielectric polarization is effect, where electrical bound charges moves by activity of outside or inside field from its balanced positions to new positions for low finite distances. If material contains polar molecules, they orient into electric field's way. The polarization scale in material are polarization vector $\mathbf{P} = \mathbf{D} - \epsilon_0 \mathbf{E}$ (Cm⁻²) and relative permittivity.

In dielectric materials usually exists a few polarization mechanisms, that weaker can be overlay by more powerful mechanism. After polarization time we make out two polarization types: flexible and relaxation. The flexible polarizations can pass at once in practice, without power loss and frequency independent in radio frequency range. By contrast relaxation polarization is typical by it, that after electric field application polarization increases slowly and similar after disconnect electric field. The times needed to stabilize these effects are relatively large. The time dependence of relaxation polarization after disconnect electrical field is characterized by response function, which study and analysis is the basic subject of dielectric relaxation spectroscopy. In all practical and technical sight the response function is in the first approximation exponential with time constant called relaxation time. The slow polarizations are temperature dependent, with following dielectric power dissipation.

2 DIELECTRIC RELAXATION SPECTROSCOPY

To diagnostics dielectric materials exists range of methods. Dielectric relaxation spectroscopy (DRS) comes from theories and methods group specified to research of measured relations in study values [2], [3]. From global look DRS is broadband measuring method with frequency range beginning about sections Hz and finishing in frequencies of optical radiation [12]. The interest centre of DRS is to get complex permittivity $\epsilon^* = \epsilon' - j\epsilon'' = \epsilon'(1 - jtgd)$ relation in frequency and another parameters. The most important parameter, which makes fundamental interest in dielectric parameters, is working temperature, eventually possibility to submit the test sample by temperature ageing process. By mentioned large frequency range of DRS is evident, that we don't manage out with only one measuring method. In radio frequency range are used two DRS methods, time and frequency domain. Frequency domain DRS is based on alternate measurements, dielectric sample is exposed into harmonic voltage activity with needed frequency range and we find the response, which is amplitude and phase of harmonic current. For frequency range beginning on very low frequencies about few μHz is used time domain DRS. The dielectric sample is exposed to step change voltage and measuring response is time dependence of dielectric current. Available frequency range depends on parameters of available measurement technique, in specific frequency range can be used several measurement methods.

3 TIME DOMAIN DIELECTRIC RELAXATION SPECTROSCOPY

Time domain DRS is subject of this paper. This measurement technique records time response (current) on step changing voltage [12], [13]. To use the recorded data from measured discharge characteristic, it's necessary to transfer them into frequency domain by suitable way [5], [11]. As the measurement result we again request frequency dependence of complex permittivity. As every measurement technique, time domain DRS has also specific troubles dedicated by measuring circuit parameters [10]. The measured time dependence is monotone growing or decreasing function and measured values are very small, usually for example about $1 \cdot 10^{-14}$ A, so not noise resistant. Corresponding measured maximum time is

very long, for example to lowest frequencies after Fourier transformation can be maximum measuring time up to a few days. The long measurement times makes necessary the stability of measuring neighborhood. On the beginning measurement is additional necessary for highest frequencies to use very short measuring time period, for example ones of μs . The next problem for future data processing is short transient process at beginning of measuring during application of voltage step change. Then time of first measurement current sample isn't zero, this conditions must be remembered for measured data processing. By explicit facts, time domain DRS demands full computer controlled workplace, for data record and processing. On fig. 1 taken over [10], [13], is displayed simplified basic input circuit for time domain measurement.

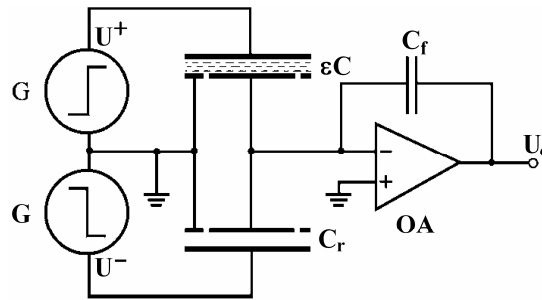

Fig. 1: Basic circuit for time domain measurements

Shown circuit contains extra reference capacitor, second step voltage generator and ideal charge detector. The reference capacitor with second step voltage generator helps decrease start response of measuring circuit, which can improve usage of measurement ranges, but with need of quality capacitor as reference and modified circuit solution.

4 TESTING

How it was presented in previous chapters, for time domain DRS it's needed digital controllable electrometer. On our workplace is available programmable electrometer Keithley 617, which performs the most of our requirements [6], [7], [9]. It is very sensitive measuring equipment, contained the voltage source. For our needs electrometer will work in very small currents measurement. The particular disadvantage of this equipment for eventually precise DRS measurement consists in insufficient quickly sampling of input signal and also in fact, that equipment don't allow control all measurement time by internal accurate time normal. The problem with slowly sampling could be theoretical worked out by using analog output of electrometer and its connecting to digital controllable multimeter with faster sampling [8]. By alone experimental discharge current measurement were verified the difficulty of small current measurements in real conditions. The resulting discharge current process is issued in logarithmic axis, see fig. 2. For this experiment was used the simple preparation consisted from metal box, dielectric sample with electrodes and four cored relays, which switches the circuit between charge and discharge process.

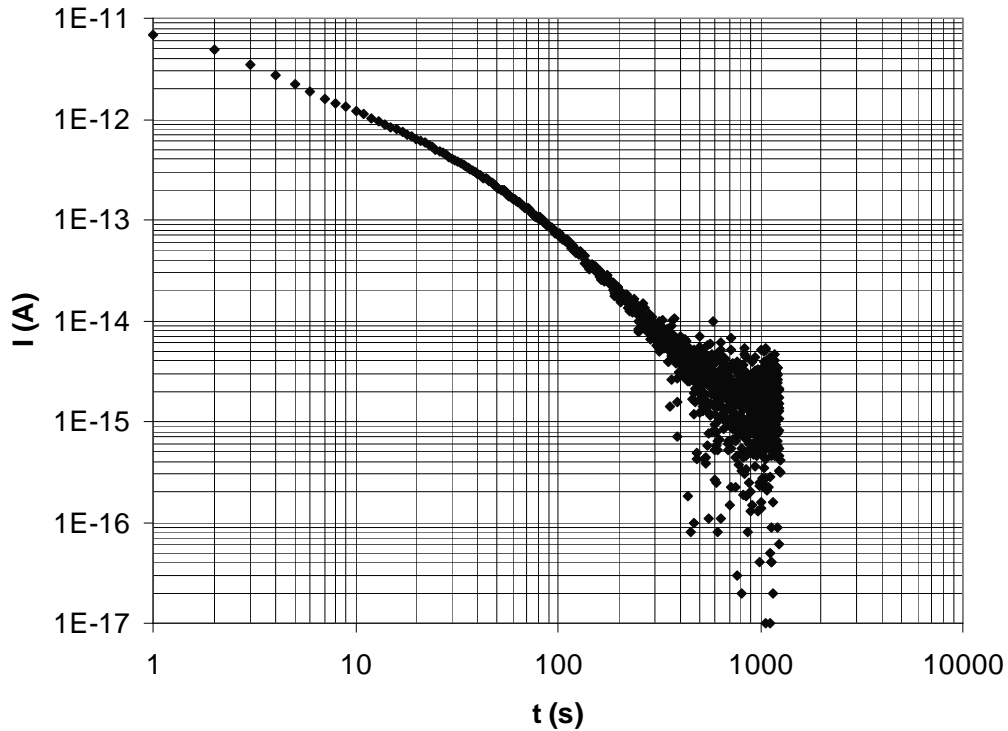

Fig. 2: *Discharge current time dependence*

As the control software of the measurement was used graphical programming system Agilent VEE Pro. This experimental measurement was made with beginning voltage on the sample 15 V and manual control of the relays to switch discharge process. There isn't recorded the initial start of transient process, which occurred at while of switching relays. Dielectric discharge current was reading in constant time period 1 s for all time of 1250 s. From made experiment results, that will be necessary to improve the shielding of test preparation and workplace. For ensuring better measuring conditions by higher rate signal to noise of measurement are theoretic available two chances: using test sample with higher area or level up the initial charge voltage. The last solutions must be considered very carefully, because they increased the risk of electrometer overload.

5 CONCLUSION

The paper deals with some experimental aspects of time domain dielectric relaxation spectroscopy. In the end the discharge characteristic of the test dielectric sample was measured by simple measurement preparation, which evidently shows the interference signal's character, which will need to properly suppress. It can be secured by precise shading of measuring preparation and workplace and also digital filter mounting for input data.

ACKNOWLEDGEMENTS

This research has been supported by the Czech Ministry of Education in the frame of MSM 0021630503 Research Intention MIKROSYN New Trends in Microelectronic System and Nanotechnologies.

REFERENCES

- [1] Bryknar, Z.: Fyzika dielektrik. 1.vyd., Praha, Ediční středisko ČVUT, 1983. 180 s.
- [2] Liedermann, K.: Dielectric Relaxation Spectroscopy. Technical University of Brno, 2004. 85 p.
- [3] Liedermann, K.: Dielektrická relaxační spektroskopie polymerních dielektrik. [Habilitation work]. VUT Brno, 1996.
- [4] Jiráček, J., Aučrat, R., Liedermann, K., Rozsivalová, Z., Sedlářková, M.: Materiály a technická dokumentace, Část Materiály v elektrotechnice. Fakulta elektrotechniky a komunikačních technologií VUT v Brně, 129 s.
- [5] Jura, P., Polanský, M.: Signály a systémy, Část 3: Diskrétní signály a diskrétní systémy. Fakulta elektrotechniky a komunikačních technologií VUT v Brně, 87 s.
- [6] Keithley Instruments, Inc., Cleveland, Ohio, U.S.A.: Model 617 Programmable Electrometer, Instruction Manual. 1984, 183 p.
- [7] Keithley Instruments, Inc., Cleveland, Ohio, U.S.A.: Low Level Measurements Handbook, 6th Edition. 2004, 230 p.
- [8] Agilent Technologies, Inc., 815 14 Street SW, Loveland, Colorado 80537, U.S.A.: Agilent 34401A Multimeter. Edition 6, 2005, 240 p.
- [9] Agilent technologies, Inc., 815 14 Street SW, Loveland, Colorado 80537, U.S.A.: VEE Pro User's Guide. 2005, 657 p.
- [10] Mopsik, F. I.: Precision time-domain dielectric spectrometer. Rev. Sci. Instrum. 55 (1), 1984, p. 79.
- [11] Petr, J., Krejčí, M.: Měření resorpčních proudů plošných izolantů. In Diagnostika 05, Západočeská univerzita v Plzni, 2005, s. 36, ISBN 80-7043-368-X.
- [12] Blochowicz, T.: Broadband Dielectric Spectroscopy in Neat and Binary Molecular Glass Formers. 2003, 241 p.
- [13] Kaatze, U., Feldman, Y.: Broadband dielectric spectrometry of liquids and biosystems. Meas. Sci. Technol. 17, 2006, p. R17.