

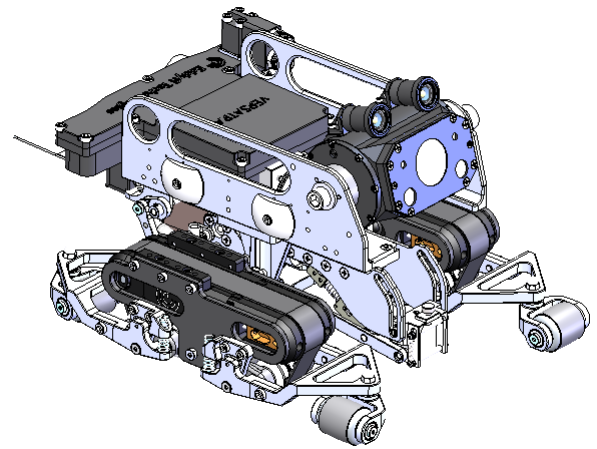

Advanced Test Equipment Corp.  
www.atecorp.com 800-404-ATEC (2832)

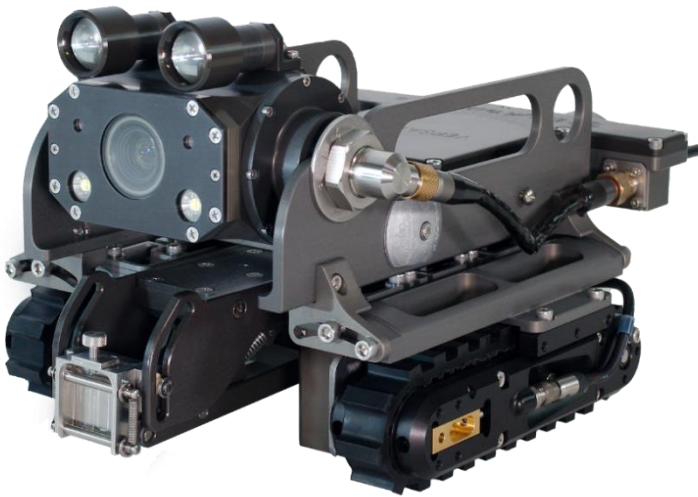

VERSATRAX™ M310 AND M345  
USER MANUAL

## Table of Contents

About This Manual .....	5
Description .....	5
Specifications .....	6
Precautions .....	7
Intended Use .....	7
Safety .....	8
Vehicle Overview .....	11
Dimensions .....	12
Laser Lines .....	13
System Setup .....	13
Personnel Requirements .....	13
Working and Storage Environment .....	14
System Power .....	14
Controller Connection .....	14
Vehicle and Tether Connection .....	15
Portable Reel Setup .....	15
Mini-Reel Setup .....	16
Tether Handling .....	17
Connector Handling .....	18
Connectors Used on the VT-M310 .....	18
SubConn Connectors: Lubrication and Cleaning .....	18
Impulse Connectors: Lubrication and Cleaning .....	19
Birns Aquamate Connectors: Lubrication and Cleaning .....	19
Scorpion Oceanics Connectors: Lubrication and Cleaning .....	19
Vehicle Configuration .....	19
Camera Mounting .....	19

Standard Mounting.....	19
Pole Mounting .....	20
Magnet Spacing .....	21
Fall Arrest.....	23
Probe Mounting.....	23
Cable Routing .....	24
Encoder Connector .....	25
Operation.....	26
Pre-Operations Check .....	26
Post-Operations Check.....	27
ICON™ Software .....	27
Driving the Vehicle.....	28
Maintenance.....	28
Galvanic Corrosion Control.....	28
Rinsing and Cleaning.....	30
Fuse Replacement.....	30
Microtrac™ Maintenance .....	30
Tether Re-termination .....	30
Troubleshooting .....	31
Camera Control Problems .....	31
Video Issues .....	31
Vehicle Issues.....	32
Tether Reel Issues.....	32
Parts and Repairs .....	33
Ordering Parts/Customer Service.....	33
Warranty Repairs .....	33
Factory Returns to Canada.....	33



# VersaTrax™ M310 and M345 User Manual

Product/System Drawing Package Availability ..... 34

Limited Warranty Policy ..... 34

User Manual

Document: UMED021776.docm	Revision: A03	Created by: SR	Date: 07-Jan-2026	IPN: 3117437-A03
Source Location:				Page 4 of 34

## About This Manual

This manual has been prepared to assist you in the operation and maintenance of your Eddyfi Technologies' Inuktun equipment. Correct and prudent operation rests with the operator who must thoroughly understand the operation, maintenance, service, and job requirements.

This product is continually being updated and improved. Therefore, this manual is meant to explain and define the functionality of the product. Furthermore, schematics or pictorials and detailed functionality may differ slightly from what is described in this manual. The specifications and information in this manual are current at the time of printing.

Eddyfi Technologies reserves the right to change and/or amend these specifications at any time without notice. Customers will be notified of any changes to their equipment.

Information in this manual does not necessarily replace specific regulations, codes, standards, or requirements of others such as government regulations.

This manual copyright © 2026 by Eddyfi Robotics Inc. All rights reserved.

## Description

The Eddyfi Technologies VersaTrax™ M310 and VersaTrax™ M345 (VT-M310/345) is a magnetic track crawler capable of driving vertically or inverted along ferrous surfaces. The magnet modules allow the vehicle to pull longer lengths of tether than could normally be achieved without magnets when travelling horizontally in steel pipes or on steel decks. A row of magnet cups is mounted next to each of the tracks. These magnet cups can be raised or lowered to adjust the magnetic adhesion or surface clearance as required.

The M345 differs from the M310 by its drive system, the specifics of which are covered in Section: The M345 Drive System.

The crawler features a high-definition camera. If the crawler is not equipped with the probe raise actuator, the camera is capable of full 360° continuous tilt range. Note, however, that there is a minimal viewing obstruction near the back of the vehicle. When equipped with the probe raise actuator, the crawler has a camera tilting range of approximately 290°.

The vehicle uses two extended tracks, mounted underneath the main chassis plate on articulating brackets that can be tilted to suit a range of pipe diameters.

The track mounting brackets can also be swapped side-to-side depending on whether the crawler is to be inside or outside of a pipe. The general rule is that if the magnets are set to the inside of the tracks, then it works best 'inside' pipe, and if the magnets are positioned outside the tracks, then the crawler works best on the outside of pipes. Either arrangement can be used on flat surfaces.

Document: UMED021776.docm	Revision: A03	Created by: SR	Date: 07-Jan-2026	IPN: 3117437-A03
Source Location:				Page 5 of 34

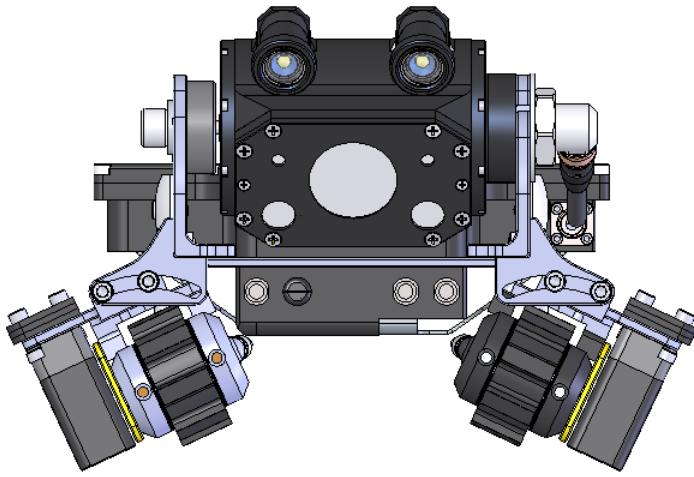

VT-M310 WITH THE TRACK/MAGNET UNITS CONFIGURED FOR USE ON AN OUTSIDE PIPE SURFACE.

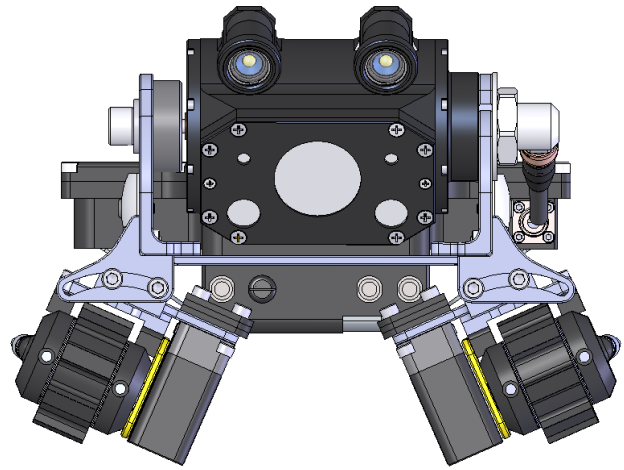

VT-M310 WITH THE TRACK/MAGNET UNITS CONFIGURED FOR USE ON AN INSIDE PIPE SURFACE.

## Specifications

			M310	M345
Min Vehicle Dimensions			538 x 297 x 211 (21.2" x 11.7" x 8.3") – L x W x H	423 x 330 x 256 (16.7"x13.0"x10.1") – L x W x H
Vehicle Weight <sup>1</sup>			13 kg (28.5 lb.)	16 kg (35lb)
Depth Rating			60 m (200 ft) or IP67 depending on purchase.	
Min Axial Pipe Driving Surface Radius <sup>2</sup>			1000mm (40") Inside, 1000mm (40") Outside	1000mm (40") Inside or Outside
Min Curved Surface Radius for Free Maneuvering			2000mm (78") Inside or Outside	1000mm (40") Inside or Outside
Maximum Tether Length <sup>3</sup>			100 m (330 ft)	
Tracks			2x Microtracs™ 4000	
Camera	Lights	Standard	2x High intensity LEDs 2x High intensity LED Spotlights @ 20 °	
	Lasers	Standard	2x Vertical Laser Lines (635 nm) @ 70 mm (2.75 in) Spacing <sup>2</sup>	
	Tilt	Range	360° (without probe raise actuator) 290° (with probe raise actuator)	
		Speed	0 – 9 °/s	

Sensor		1/2.8in Exmor R CMOS
Lens	Standard	3.8 mm (Wide) to 38 mm (Zoom) focal length
		120x Zoom (10x Optical Zoom, 12x Digital Zoom)
		67 ° HFOV (air)
Focus		Manual or Auto
Resolution		1920 x 1080
Format		HD 1080i (60 fps)
Minimum Illumination		1.4 lux
Depth of Field		10 mm (0.4in) to infinity
Reel		Portable tether reel with payout encoder
Power Requirements (System)		100 – 240 V <sub>AC</sub> 50/60Hz, 300W
Operating Temperature		0 – 40 °C (32 –122 °F)
Storage Temperature		-20° – 60 °C (-4 –140 °F)

<sup>1</sup> Weight may vary depending on optional components, including probes.

<sup>2</sup> Minimum surface radius is based on magnetic adhesion when driving vertically or inverted – see *Magnet Spacing*.

<sup>3</sup> Actual travel distance may be decreased depending on inspection geometry (traction and number of bends).

## Precautions



**IMPORTANT:** When configuring a 70V system, check to see if the tracks are compatible. Older versions of 4000 series Microtracs are not 70V compatible. The wide input voltage symbol  located on the side plate of the 4000 series Microtracs indicates 70V compatibility.



## Intended Use

The VT-M310/345 is an industrial inspection vehicle intended for crawling on steel walls, tanks, and structures and to provide close-up or zoom HD video of the inspection target, which could be a weld, paint covering, etc. The depth rated VT-M310/345 may be used above or below the waterline up to 60 m (200 ft) deep, or in dry environments. The M310 may also be used in non-magnetic environments with removal of the magnet cups.

Typical applications include:

- Underwater weld and paint inspection.
- Potable water system inspection.
- Steel Tank inspection.
- Large diameter pipe inspection.
- Mobile platform and remote sensing.
- Reactor vessel inspection.

Misuse of the system is deployment in a situation for which it is not rated, or incorrect handling.



Examples of misuse include:



Document: UMED021776.docm	Revision: A03	Created by: SR	Date: 07-Jan-2026	IPN: 3117437-A03
Source Location:				Page 7 of 34



- In a vacuum.
- Beyond its depth rating without factory approval.
- Above or below its temperature rating.
- Use in a potentially explosive atmosphere.
- Use in incompatible chemical environments.
- Very high radiation environments (Beta / Gamma).
- Prolonged overload (Payload or pulling load).
- Camera pointed at the Sun or at intense lighting.
- Mechanical impacts & scraping during deployment / magnetic slamming / dropping.
- In salt water without an anode.

## Safety

To use this product properly and safely, every user must first read these operating instructions and observe the safety instructions contained therein. Take care of these operating instructions and keep them in a place where they can be accessed by everyone. Untrained personnel should not handle or operate this equipment.

	<b>CAUTION:</b> Failure to follow these safety instructions may result in injury or equipment damage.	
---	---	---

	<b>WARNING: Hazardous Voltage 36-70 VDC.</b> If the equipment is powered from a source other than an Eddyfi Technologies provided controller, the power supplied to the product must have reinforced isolation from the mains with no reference to earth ground.	
	<b>WARNING: Spark Hazard</b> - Under no circumstances should this equipment be used in a potentially explosive atmosphere.	

	<b>WARNING: Intense Optical Radiation</b> - The VT-M310/345 camera lights are extremely bright. Never look directly at the lights. Use a welding filter (shade #8 or higher) if inspecting the LEDs.	
	<b>CAUTION: Class II Laser:</b> Do not intentionally stare into the beam. Typically, Class II relies on the blink reflex to limit exposure to no more than ¼-second. Intentionally staring into the beam can cause eye injury.	

	<b>WARNING: Trip Hazard</b> - Never stand on the tether. A snap load to the tether may pull it out from underneath you and cause you to fall. Standing on the tether
---	--

may also damage its internal conductors, cause unnecessary wear, and decrease its life.





**WARNING: Magnetic Pinch Hazard** – The magnetic chassis is fitted with rare earth magnets. These magnets are very strong and create an imminent pinch hazard. Use caution when handling the magnets or the vehicle near steel objects and tools, they may snap together unexpectedly.

**WARNING: Medical Hazard** – Operators with magnetically sensitive medical implants should be aware of and follow appropriate practices.

**WARNING: Electronic Device Interference** – Magnetically sensitive devices, including computer hard drives, cell phones, watches and credit cards may be disrupted or damaged by the magnetic field.

**Note:** Rare earth materials are mechanically weak, and magnetically very strong. They must therefore be handled very carefully to avoid damage.

	<p><b>Warning: Avoid Magnetic Slamming.</b> Extreme care must be taken when handling the vehicle, particularly when placing it onto a wall or into its storage box. Without taking heed of the sudden pull of the magnetic field onto a surface, the VT-M310/345 can be slammed down hard causing damage to the vehicle. Using a solid grip on the vehicle, we recommend touching down the vehicle on one side first and then pivoting flat.</p>	
	<p><b>Note:</b> To reduce risk of injury and damage to equipment, always store the VT-M310/345 vehicle in its <b>magnetically shielded storage and shipping box</b> or store the magnets on a <b>steel plate</b> when not in use.</p>	
	<p><b>Note:</b> We strongly recommend using gloves when handling the vehicle to reduce magnetic pinching hazard.</p>	



**WARNING: High Temperature** - The camera head and auxiliary lights may become extremely hot during operation. Allow a cool-down period before handling.



**WARNING: Falling Object** - A lifeline or fall arrest system should be used at all times when the vehicle is navigating on a vertical or inverted horizontal surface. When the vehicle is climbing, never stand below the vehicle operations area.

- Observe safe lifting practices. For storage and shipping, the V-M310/345 system is packed in three parts: Controller, Vehicle and Tether. Each of the three components is either built or packed into its own protective case with a carrying handle. The heaviest case, containing the tether and mini-reel, is equipped with wheels and an extending handle like a suitcase.
- Do not operate the system with damaged wires. A short circuit may damage the power system, telemetry system, cameras, or attached equipment. Exposed wires may also create a shock hazard.
- Disconnect the power source before servicing the product; otherwise, damage may result.
- All personnel operating or maintaining this equipment must be trained and competent.
- Eddyfi Technologies equipment is used in varied environments, ranging from hot/dry, to confined spaces, to deep underwater. Such diverse environmental risks must be addressed by the operators who are trained to work in such surroundings. As such, the operator is responsible for determining safe site setup and appropriate personal protective equipment (PPE) for operation and maintenance of the equipment.

Document: UMED021776.docm	Revision: A03	Created by: SR	Date: 07-Jan-2026	IPN: 3117437-A03
Source Location:				Page 10 of 34

Vehicle Overview

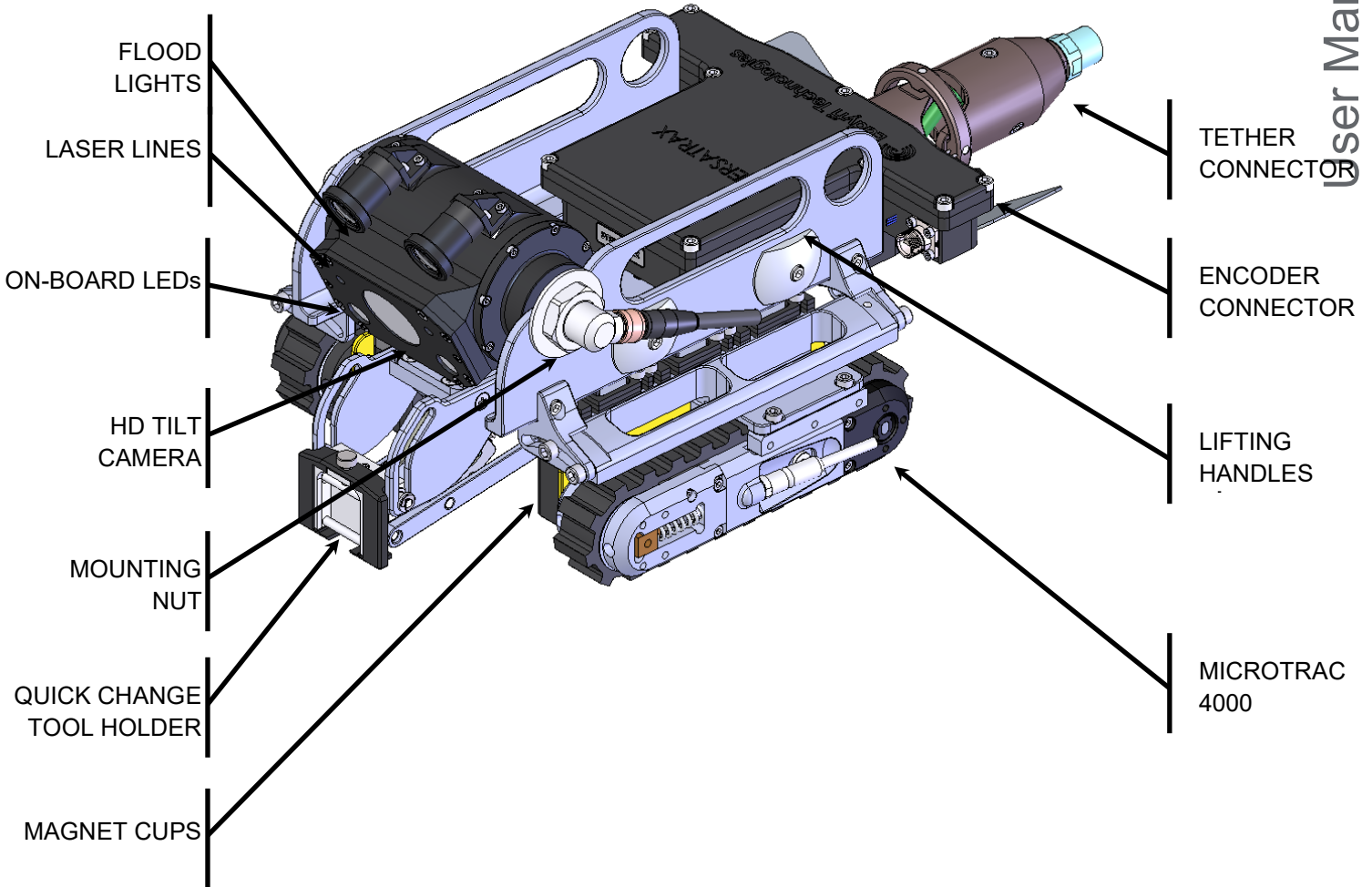

Dimensions

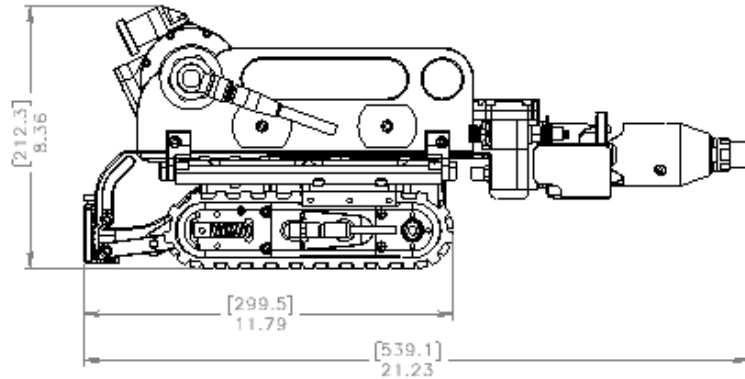
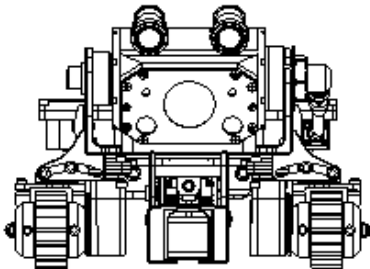
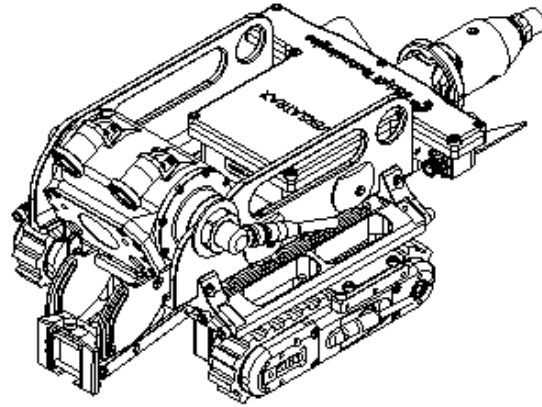
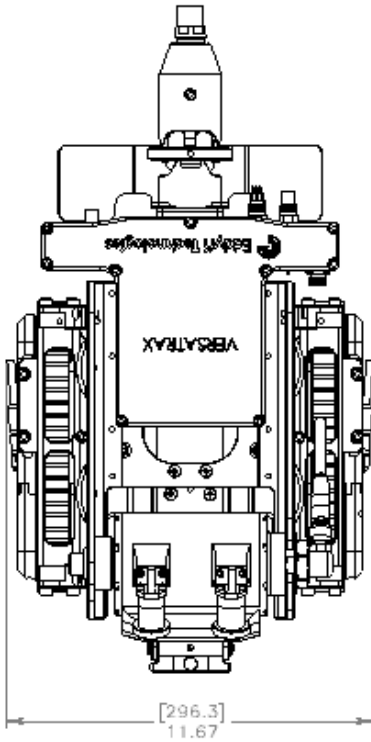

## Laser Lines

The VT-M310/345 is equipped standard with vertical laser lines (Class II lasers at 635 nm, 1.5 mW). The laser line separation is 70 mm (2.75 in).

**CAUTION:** Class II Laser: Do not intentionally stare into the beam. Typically, Class II relies on the blink reflex to limit exposure to no more than ¼-second. Intentionally staring into the beam can cause eye injury.

When performing maintenance or functional checks of the lasers and camera lights, take precautions to protect nearby personnel from unintended exposure which could be temporarily blinding.

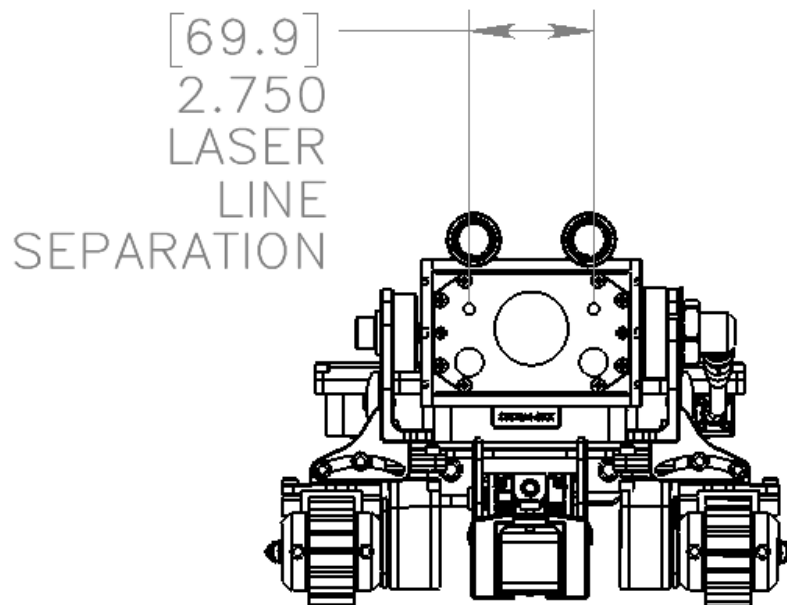

## System Setup

### Personnel Requirements

Basic deployment of the VT-M310/345 system may be performed by one person. Operations at more complex worksites may require two people, especially when the console location is removed from the point of deployment.

- **Console Operator:** This person is responsible for driving the vehicle, watching the location of the inspection and making comments about it and the surrounding conditions. It is also the operator's responsibility to assess whether the location of the inspection is in the appropriate condition for safe passage of the vehicle or if there is a risk of getting stuck. The operator may also assist in general site setup (cones, warning signs, etc.), vehicle maintenance and configuration.
- **Deployment / Tether Handler / Field Maintenance:** This person has several tasks including:
  - Configuring the vehicle for the current inspection.

Document: UMED021776.docm	Revision: A03	Created by: SR	Date: 07-Jan-2026	IPN: 3117437-A03
Source Location:				Page 13 of 34

- Placing and retrieving the vehicle to and from the inspection area.
- Watching the tether as the vehicle enters and exits the inspection.
- Operating the reel and winding the tether during recovery.

Establish a good channel of communication between the operator and deployment personnel. Good communication can avoid accidents, damage to the equipment, and promotes efficiency and productivity. In particular, the person deploying the vehicle and watching the tether must be able to quickly tell the operator to stop the vehicle if something goes wrong. The operator should never turn on power or initiate movement without first communicating with the vehicle handler.

## Working and Storage Environment

The control system (interface box, power supply, and control computer) is to be used in a **dry, covered** environment only. These components are not waterproof. Keep all cords and cables away from water.

The **tether and vehicle** are depth rated to 60 m (200 ft) of water. The tether connector is a wet-mate type which may be wet when plugged in but cannot be plugged in underwater. Keep the tether connector capped with a dummy plug when not connected to the vehicle to help keep out dirt. The tracks are tolerant to sandy and muddy conditions, although this decreases seal life. The vehicle may also be operated in dry or dusty environments.

Refer to the reel and controller manuals for their environmental conditions.

To maximize component life and minimize deployment time it is recommended that the vehicle and tether be cleaned after use and the entire system stored in a dry and dust-free location.

System **storage temperatures** are between -20 °C – 60 °C (-4 °F – 140 °F)

## System Power

The VT-M310/345 is operated through an ICON™ Controller 100 (IC100), an ICON Controller 500 (IC500), or a Rackmount Interface Box. These controllers provide power to the tether and vehicle.

Refer to the Controller User Manual for further details and power requirements.

When powering the system from a generator or inverter, refer to that unit's operating manual for recommendations on continuous and peak load ratings. These power sources may apply a reduced output rating based on electrical load and environmental temperature. Remember to include the power needs of all other connected devices (external monitors, recording devices, lighting, etc.) when selecting a generator or inverter.

## Controller Connection

The controller supplies power to the tether and vehicle. It provides a communication interface to the vehicle. It also provides video reception and distribution.

Refer to the Controller Setup section of the controller User Manual for more information.

Document: UMED021776.docm	Revision: A03	Created by: SR	Date: 07-Jan-2026	IPN: 3117437-A03
Source Location:				Page 14 of 34

## Vehicle and Tether Connection



**IMPORTANT:** Never “Hot Plug” any connector, this will result in internal damage to the electronics. Power down the system prior to connecting or disconnecting the inspection system tether or any of the vehicle whips.

The tether and vehicle are depth rated to 60 m (200 ft) of water. The tether connector and track connectors are dry-mate types which must be dry when making a connection. Keep the tether connector capped with a dummy plug when not connected to the vehicle to help keep out dirt.

It is important that the tether be properly connected to the vehicle.

1. Connect the vehicle end of the tether to the back of the harness block. Visually line up the key in the connector before mating. Fully screw down and hand tighten the locking collar.
2. Verify the track and camera whips from the harness block to their respective components are securely connected, and the whips are free from damage.

## Portable Reel Setup

If your system includes a portable reel, follow these steps to operate:

1. Remove the shipping cap from the front of the case and insert the crank handle.
2. Connect the deck cable from the reel to the controller.
3. Disengage the packing brake (pull back and turn on the locking pin).
4. Make sure the friction brake is **engaged** - disengaging the friction brake can result in slack tether resulting in potentially jamming the reel.
5. Unwind some tether and connect the tether to the vehicle.
6. Run the tether through the level wind as follows:
  - a. There is an access slot which must be opened by lifting up on the two exposed screw heads to raise the tether support shafts.
  - b. Pull up on both sides of the axle on the top wheel and slide the tether beneath it - failing to lift up on the wheel can scuff and damage the tether.
  - c. Make sure that the two wheels that sandwich the tether top and bottom in the level wind are tracking properly as the tether is paid out - this tells the controller how much tether the reel has unwound and how far your vehicle has travelled.

Document: UMED021776.docm	Revision: A03	Created by: SR	Date: 07-Jan-2026	IPN: 3117437-A03
Source Location:				Page 15 of 34

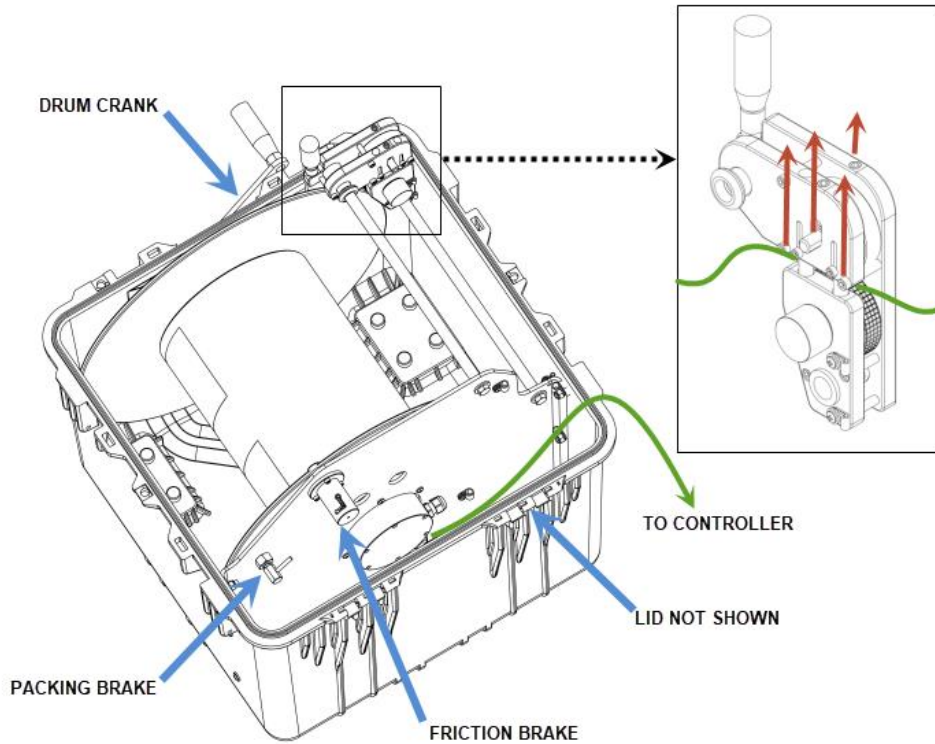

## Mini-Reel Setup

If your system includes a Mini-Reel, follow these steps to operate:

1. Remove the Mini-Reel from the shipping case.
2. Connect the deck cable from the reel to the Video Interface and Power Supply.
3. Connect the encoder deck cable from the reel to the Video Interface and Power Supply (if provided with Mini-Reel).
4. **Disengage** the shipping brake.
5. Make sure the friction brake is **engaged** – disengaging the friction brake can result in slack tether resulting in potentially jamming the reel.
6. Unwind some tether and connect the tether to the vehicle.

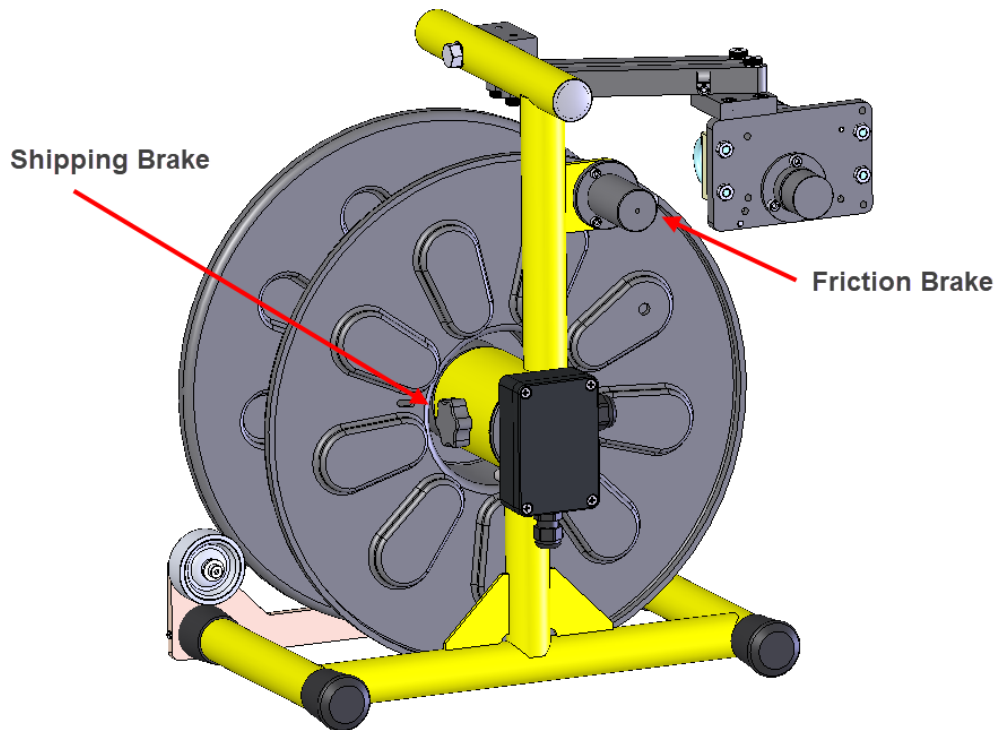

## Tether Handling

**The tether is one of the most important parts of the system.** It feeds power and control signals to the system and returns data to the controller. If the tether is damaged from improper use, poor handling or an accident, the system may become inoperable. This could lead to significant downtime, loss of production, and avoidable costly repairs. It is encouraged to stress the importance of the tether and its use to anyone operating or maintaining the system. For maximum tether life and reliability, we recommend the following tether handling tips.

- Do not step on the tether.
- Do not drive over the tether.
- Do not bend the tether beyond its minimum bend radius.
- Do not kink the tether.
- Do not snap load the tether.
- Avoid loading the tether whenever possible.
- Always use the cable grip strain relief if applicable to your system.
- Regularly inspect the tether for damage.
- Regularly clean the tether.

**Note:** Protecting the conductors inside the tether is critical to the life and operation of the tether. Proper tether handling and care will result in extended tether life and system reliability.

Document: UMED021776.docm	Revision: A03	Created by: SR	Date: 07-Jan-2026	IPN: 3117437-A03
Source Location:				Page 17 of 34

## Connector Handling

Connectors are an essential part of system reliability. They should be properly maintained and cared for to ensure long life and reliability. It is recommended to follow these steps to help prevent damage and increase the life of connectors.

- Always put the cap back on the tether bulkhead when the tether is disconnected.
- Always inspect the end of the connector prior to engaging.
- Never plug in a dirty or damaged connector.
- Visually align keyways or locating pins prior to engaging the connector.
- Always fully engage or tighten the connector.
- Secure locking collars finger tight.
- Install dummy plugs on unused connectors.
- Disconnect by pulling straight, not on an angle.
- Do not pull on the cable to disengage the connector.



**IMPORTANT:** Never “Hot Plug” any connector, this will result in internal damage to the electronics. Power down the system prior to connecting or disconnecting the inspection system tether or the vehicle whips.

**Note:** Never use WD-40 or similar solvent-based fluids on connectors or crawlers. These will cause the rubber parts of the connector or crawler to soften and swell rendering them inoperable.

## Connectors Used on the VT-M310/345

Connector Location/Usage	Connector Type Depth Rated	Connector Type IP67
Tether Connector	Impulse	Impulse
Tracks and Actuators	Impulse	Attend
Encoders	Birns Aquamate	Attend
Camera (Interconnect Box end)	Scorpion Oceanics	Scorpion Oceanics
Camera (Camera end)	Impulse	Impulse

## SubConn Connectors: Lubrication and Cleaning

- Periodically apply Molykote 111 silicone grease or equivalent before mating connectors.
- For dry mate connections, a layer of grease corresponding to 1/10 the socket depth should be applied to the female connector.
- After greasing, fully mate the male and female connector and remove excess grease from the connector joint.
- General cleaning and removal of sand or mud on a connector should be performed using a spray-based contact cleaner like isopropyl alcohol.

### Impulse Connectors: Lubrication and Cleaning

- Lubricate mating surfaces regularly with 3M Silicone spray or equivalent, Do not use grease.
- Lubricate O-rings with Molykote 111 or equivalent.
- Use dust caps to protect connectors wherever possible.
- Clean connectors with soap and fresh water, rinse out with alcohol and allow connector to air dry before using.

### Birns Aquamate Connectors: Lubrication and Cleaning

- Lubricate the mating surfaces with a PTFE-based lubricant such as Super Lube® by Synco
  - Use grease for O-rings and aerosol for connectors.
- Use isopropyl alcohol or soap and water to clean the connectors.

### Scorpion Oceanics Connectors: Lubrication and Cleaning

- Do not apply grease to the connectors.
- Lightly lubricate O-rings with Molykote 111 or equivalent.
- General cleaning of the connector should be performed using a soft bristle brush and isopropyl alcohol.
- A gentle air blast can be used to facilitate cleaning and to flash off the isopropyl alcohol.
- No thinners or abrasives should be used to clean the connectors.

## Vehicle Configuration

### Camera Mounting

The VT-M310/345 camera can be mounted in a standard configuration or can be removed from the vehicle and mounted on an accessory pole. The camera can also be mounted in an alternate orientation option.

### Standard Mounting

To install the camera onto the vehicle, do the following (removal is the reverse of installation):

1. Make sure the starboard axle screw is fully disengaged (tip should be slightly recessed in round housing).
2. Slide the camera between the chassis fairings, make sure the connector is oriented as shown and the washer is located with the locking nut on the outside of the fairing (see below).
3. Making sure the connector stem is seated all the way down in the port fairing slot, tighten the axle screw; make sure it cleanly enters the bronze bushing in the camera head.
4. Tighten the port side locking nut.
5. Connect the camera whip to the bulkhead connector.

Document: UMED021776.docm	Revision: A03	Created by: SR	Date: 07-Jan-2026	IPN: 3117437-A03
Source Location:				Page 19 of 34

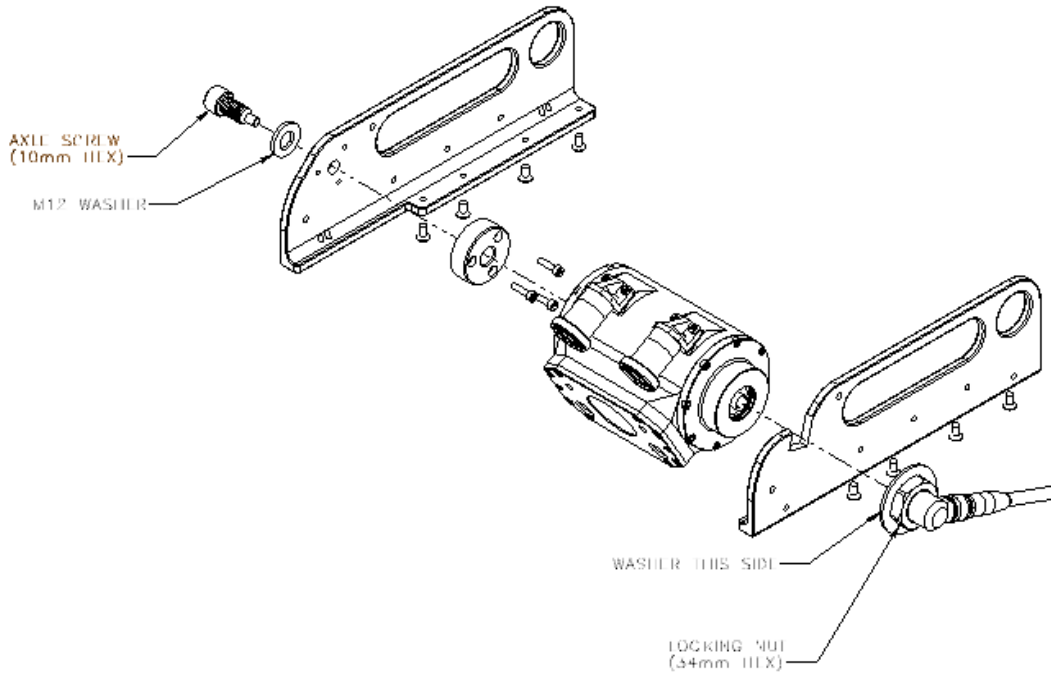

## Pole Mounting

Mounting the camera onto the optional inspection pole is nearly identical to the standard installation (see below).

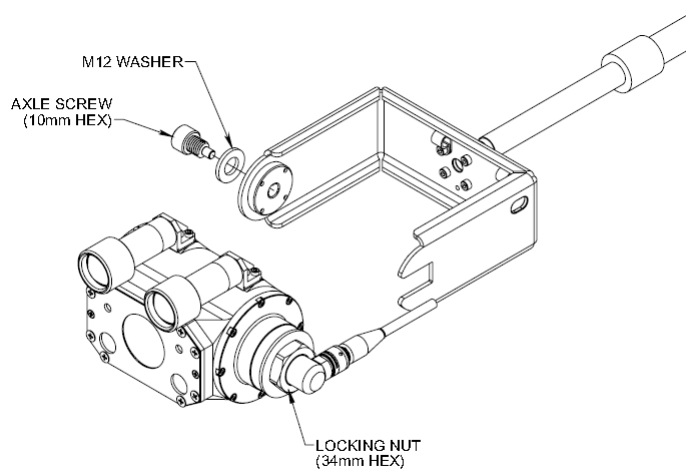

## Magnet Spacing M310

The VT-M310 vehicle comes equipped with magnet cups to enable the vehicle to maneuver on a vertical or inverted magnetically attractive surface. The magnet cups utilize rare earth permanent magnets and cannot be disabled (or turned off).

The inspection surface must be carbon steel or alloy steel that has good magnetic properties. Most structural steels are strongly magnetic. 300 series stainless steels and some other alloys are not. The client may be able to identify their metal and look up its properties or test it with a magnet.

It is important to note that the magnet cups lose magnetic adhesion as they move away from the attractive surface. The operator needs to pay attention to the distance between the magnet cups and the surface. If the magnets are too close to the surface, the Microtracs™ may not be able to overcome the added friction for skid steering. If the magnets are too far away the vehicle may lose magnetic adhesion. The distance from the magnet cups to the inspection surface can be adjusted by the operator by adding or removing the magnet spacers. The thickness of the steel surface also affects the amount of magnetic adhesion provided by the magnets.

Some considerations when determining magnet spacing:

- Thickness of stainless, plastic, or concrete cladding over the carbon steel surface.
- Uneven surfaces such as large welds.
- Thickness of magnetically attractive surface (0.20in minimum is ideal).
- Curvature of inspection surface.

The VT-M310 vehicle comes with the magnet cups mounted to the track mounting bracket and includes a stack of magnet spacer plates. These spacers are designed to be easily moved above or below the mounting bracket to change the height of the magnet cups.

The mounting hardware used for the magnet cup mounting does not have to change as the spacers are relocated above or below the track mounting bracket:

- It is best to remove the track/magnet unit by removing the two socket head screws on each end of the track mounting bracket.
- Carefully remove the track/magnet unit from the chassis and place away from any ferrous metal surface or objects such as tools.
- Loosen the three socket head screws that hold each of the magnet cups, but do not remove.
- Gently slide steel plate under magnets. This will keep them aligned and make adjustment easier.
- Slide desired spacer plate out and relocate either between the magnet cups and the bracket to lower the magnets, or above the bracket to raise the magnets, using the provided plastic prybar to assist.
- Retighten the magnet cup mounting socket head screws.
- Reposition the track/magnet unit in the chassis and reinsert the two socket head screws in each end of the bracket.
- Ensure the track/magnet unit is angled as desired and tighten the two socket head screws at each end of the mounting bracket.
- Repeat for the second track/magnet unit.

Document: UMED021776.docm	Revision: A03	Created by: SR	Date: 07-Jan-2026	IPN: 3117437-A03
Source Location:				Page 21 of 34

When remounting the tracks, make sure the whips are securely connected, and the locking collars are fully engaged. Be careful not to pinch the track whips, and route them upwards towards the front of the interconnect box, under the main chassis plate.

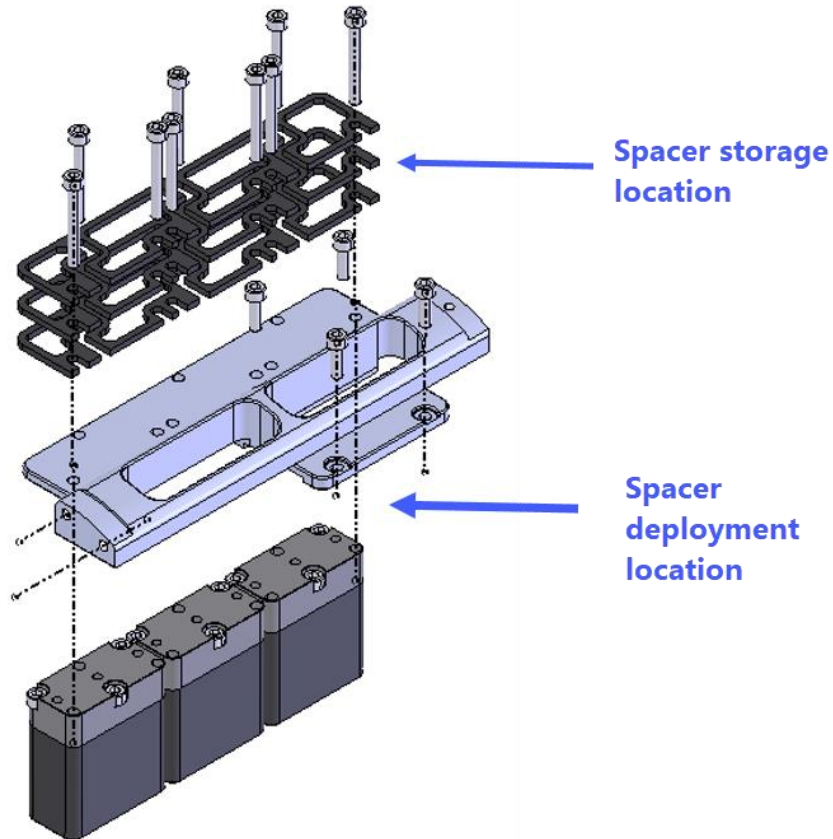
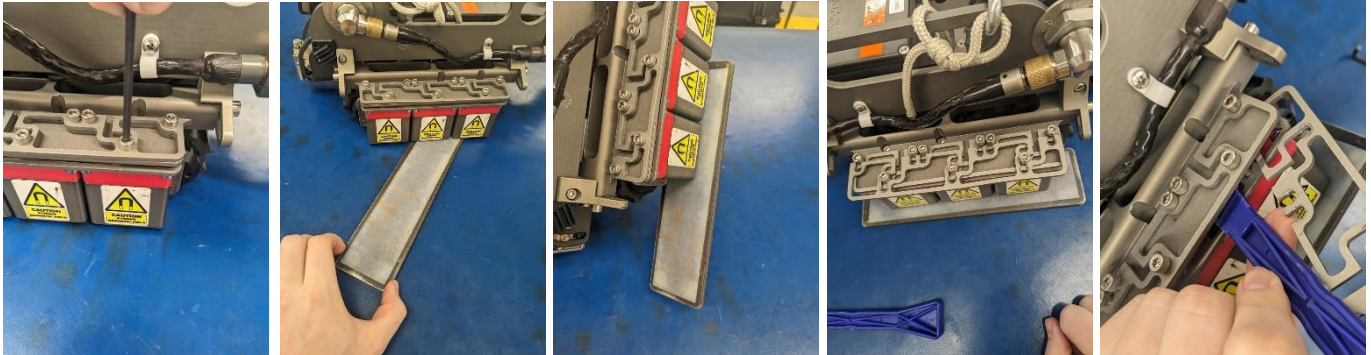

## The M345 Drive System

The M345 differs from the M310 only in its drive system. The M345 uses its tracks to drive a set of pivoting magnetic wheels. The wheel set deforms to the curvature of the drive surface, ensuring consistent adhesion in every orientation. This system has a larger profile, imposing a larger minimum insertion diameter of 345mm on the vehicle.

The advantage of this system is that the M345 can freely maneuver on tighter curvatures than the M310, and in ideal circumstances, with significantly higher magnetic adhesion.

The adhesion force of the magnetic wheels will fall off very quickly if separated from the ferrous surface, even 1mm of paint can significantly decrease total adhesion. If this surface is also wet or oily, the vehicle will have drastically reduced traction and could slip. Use discretion in these circumstances.

While the higher magnetic adhesion permits higher payloads, the pivoting mechanism exposes the vehicle to “peeling off” under certain conditions. Consult with eddyfi before using higher payloads than recommended.

## Fall Arrest



**IMPORTANT:** A lifeline or fall arrest system should always be used when vehicle detachment from the working surface threatens injury to personnel or damage to equipment. A fall arrest system can be attached to the vehicle on either or both safety loops.

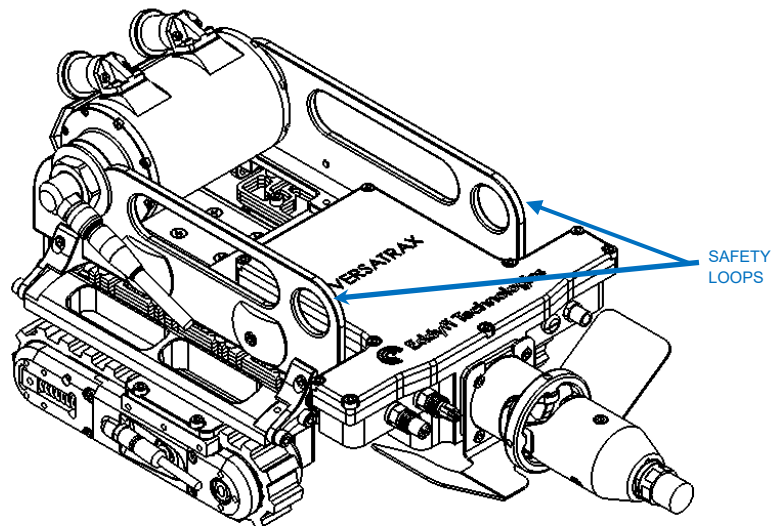

## Probe Mounting

The VT-M310/345 has the capability for utilizing many different types of probes and tooling through use of its quick tool mount, located at the front of the raise actuator with a thumb screw lock. When installing a new probe or tool, back off the thumb screw until the top retaining bar can move freely. Install the mounting connector such that it fits between the bars and then tighten the thumb screw to secure the tool.

Document: UMED021776.docm	Revision: A03	Created by: SR	Date: 07-Jan-2026	IPN: 3117437-A03
Source Location:				Page 23 of 34

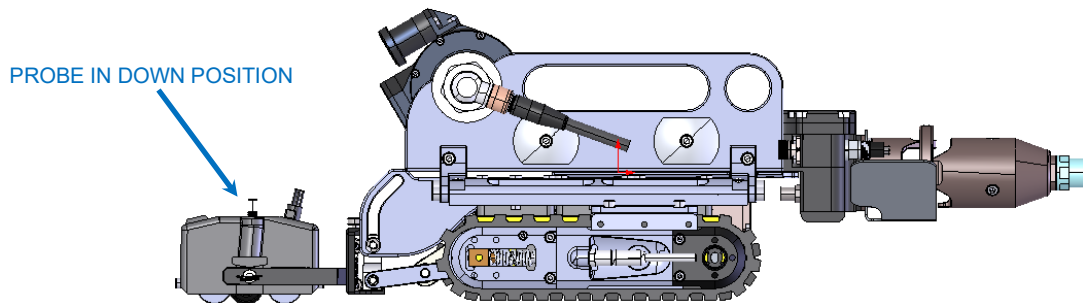
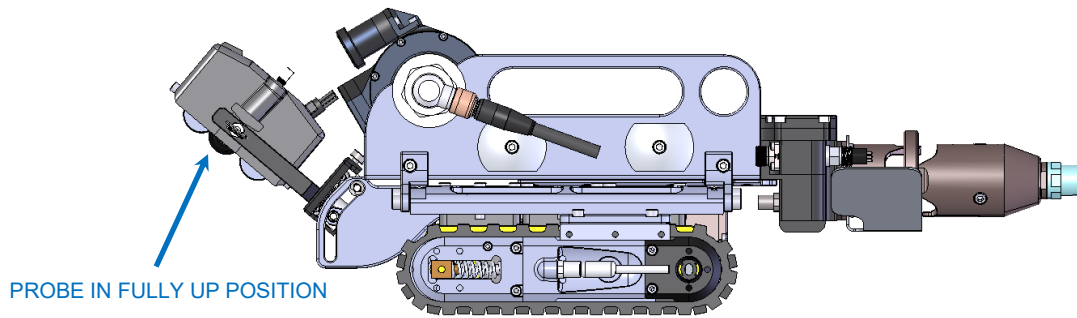
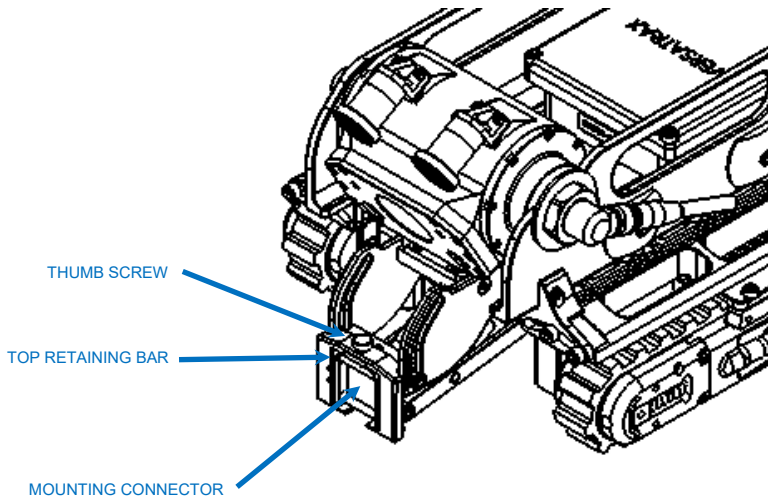

## Cable Routing

For probes and accessories mounted to the VT-M310, a channel is available on the chassis to route connection cables. For NDT probes attached to the vehicle, ensure that their cables are routed on the inside of the left side plate. Quick connect clips are provided in this area. For other accessories and

Document: UMED021776.docm	Revision: A03	Created by: SR	Date: 07-Jan-2026	IPN: 3117437-A03
Source Location:				Page 24 of 34

modules. Cables will be routed to the inside of the right side plate. Feed it under the right of the camera and along between the interconnect box and the right-hand side plate.

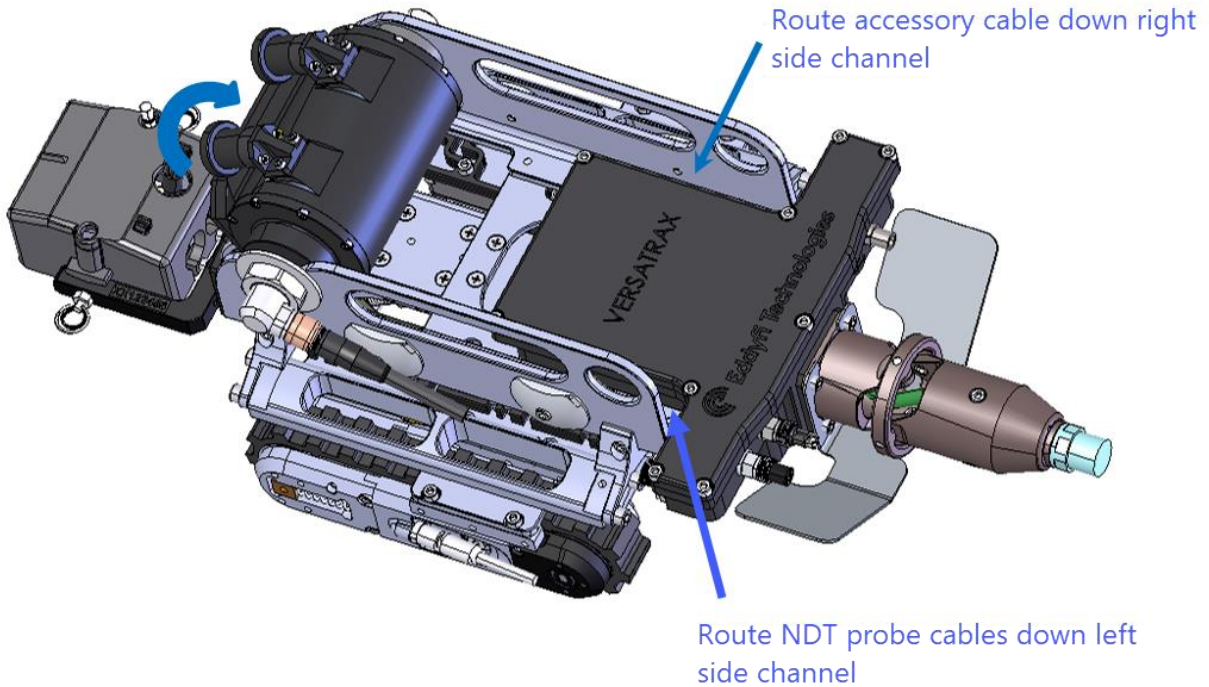

## Encoder Connector

The VT-M310 comes equipped with an encoder input connector on the rear of the interconnect box if the vehicle is equipped with an encoder, there is also an encoder output connector which provides raw encoder counts from the encoder module to a third-party UT controller. The figure below shows the required connections between a UT controller and the VT-M310. The pinout of the mating connector should match the pinout of the connector on the encoder interconnect box.

Mating connector: Birns Aquamate, 7-Position, Female, TC Series

The tracks use quadrature encoding with 10-bits of resolution and 256 pulses-per-revolution.

For the purposes of obtaining UT measurements, it is intended that the VT-M310 is driven in a straight line. The raw encoder counts come from only one of the MC4000 tracks, so turning the vehicle may lead to inaccurate distance measurements for UT scans.

Document: UMED021776.docm	Revision: A03	Created by: SR	Date: 07-Jan-2026	IPN: 3117437-A03
Source Location:				Page 25 of 34

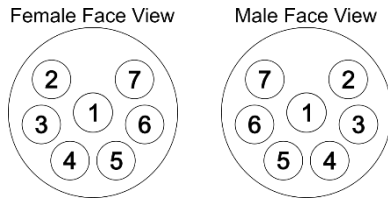

Pin Number	Wire Color	Function
1	Black	5 V <sub>DC</sub> <sup>1</sup>
2	White	GND
3	Red	Encoder A
4	Green	<i>Not Connected</i>
5	Orange	Encoder B
6	Blue	<i>Not Connected</i>
7	Brown	<i>Not Connected</i>

1. Do not connect to this pin.

## Operation

### Pre-Operations Check

Before each deployment of the VT-M310/345 system, ensure everything is completed on the following checklist.

- Check that the work area has been safely set up.
- Fall arrest is in place for vertical or inverted use.
- Check that the line voltage available at the worksite matches the equipment setup.
- Check that the power and deck cable connections are correct.
- Check the vehicle for the following:
  - Check that the vehicle is in the correct configuration for the deployment.
  - Check the vehicle for mechanical damage to the chassis or cable harnesses which could affect its operation.
  - Ensure that all fasteners are in place and secure. Check the fasteners holding on cameras, lights, tracks, and the harness block.
  - Visually inspect the vehicle and Microtracs™ to ensure that the moving parts are free of debris and functional. Make sure the track belt is free of debris and turns freely.
  - Check the tether and vehicle whips for damage.
  - Ensure camera, light, and laser ports are clean.
- Check the reel for the following:
  - Check that nothing will block movement of the level wind shuttle.
  - Check that the tether has no loose, dangling coils. Dangling coils can propagate as the drum rotates and have the potential to jump the drum. Take care of these before deploying the tether.
- Power up the system and check the following:
  - Check for sufficient SSD drive space for recording.

- Check that the record directories are set.
- Test video recording.
- Test the laser lines
- Test the auxiliary lights.
- Test track control.
- Test camera control.
- Test the controller E-Stop functionality by pressing it in and releasing it (if equipped).

### Post-Operations Check

A Post-Ops inspection should be carried out after every deployment using the following checklist:

- Inspect the tether for damage as it is reeled in.
- Visually inspect vehicle for entrained debris or mechanical damage.
- Test each function to ensure proper operation.
- Clean the system by hosing it down with water at regular line pressure. Do not pressure wash. The tracks may be cleaned off by hosing them down while running. If the system has been used in salt water, thoroughly rinse the vehicle with fresh water right away.
- Take time to pack the system properly for transport away from the worksite.
- Store the system in a dry environment.

**Note:** Ensuring the VT-M310/345 system is always stored in good working condition will minimize deployment time for future inspections.

### ICON™ Software

Vehicle control, video recording and export are accomplished using ICON™ Software graphical interface controller software.

- ICON Manual – Accessed through ICON or Desktop Shortcut.

Document: UMED021776.docm	Revision: A03	Created by: SR	Date: 07-Jan-2026	IPN: 3117437-A03
Source Location:				Page 27 of 34

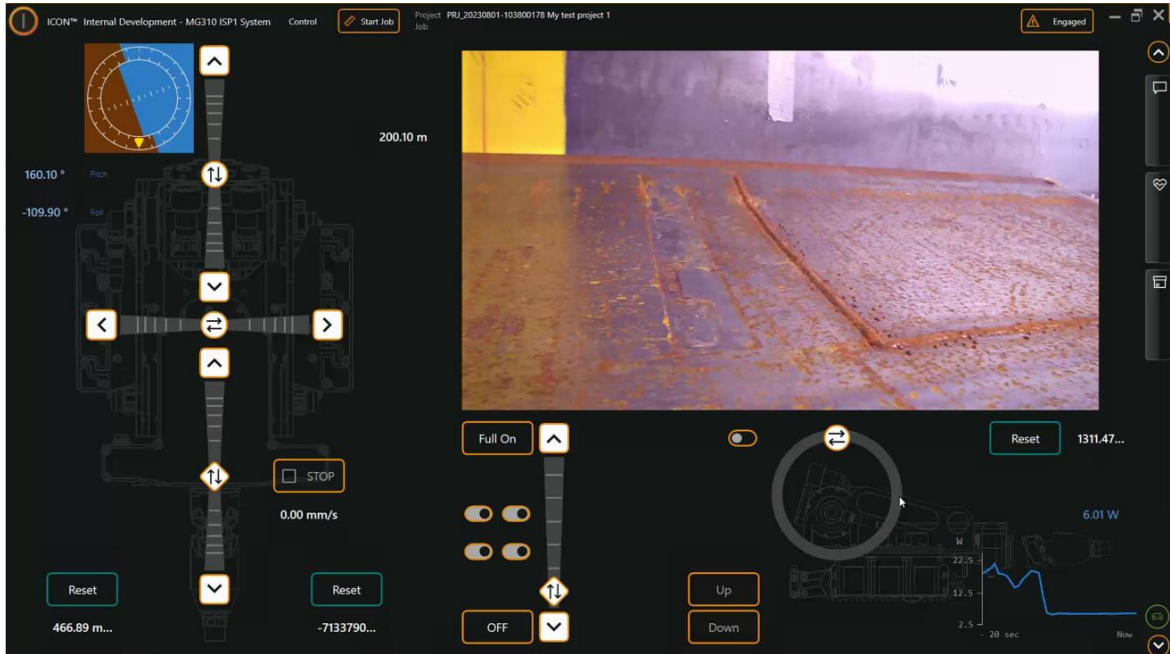

## Driving the Vehicle

When driving the vehicle, the operator should always be conscious of things that could cause the vehicle to disengage from the driving surface, either by drastically increasing magnet gap or overcoming the magnetic force entirely. These include the following:

- Welds or obstacles that are too large for the vehicle.
- Inward bulges or curves that increase magnet distance.
- Sheathing or coatings that increase magnet distance.
- Tensioning the tether at a large angle from the driving surface (approaching perpendicularity).

Always try to minimize the above risks to avoid system damage.

## Maintenance

### Galvanic Corrosion Control

Eddyfi Technologies strongly recommends cathodic protection whenever the VT-M310/345 is being deployed in a saltwater environment – either submerged or in salt spray.

Eddyfi Technologies' vehicles are designed to use **aluminum** marine anodes. Aluminum anodes are common in the marine industry and are replacing zinc anodes in many areas. For vehicle systems that are often pulled in and out of the water, aluminum anodes are especially important, as zinc anodes tend to scale over when exposed to air and may not reactivate when submerged again. An aluminum anode will always reactivate.

Document: UMED021776.docm	Revision: A03	Created by: SR	Date: 07-Jan-2026	IPN: 3117437-A03
Source Location:				Page 28 of 34

If the vehicle is being carried by a transport device, for example, a larger ROV, we recommend it also be protected by **aluminum** anodes or the two vehicles be electrically isolated from one another. Do not mix anode types (zinc and aluminum) on the assembly, between vehicles or between structures. There must be only one anode type throughout. Magnesium anodes must never be used with Eddyfi Technologies equipment.

These are pre-installed onto every device, however, should you ever need to replace them refer to the following image. They are installed using never seize on the screw rather than Loctite. Contact your sales representative for anode replacements.

ANODES ARE SECURED ON BOTH SIDEPLATES

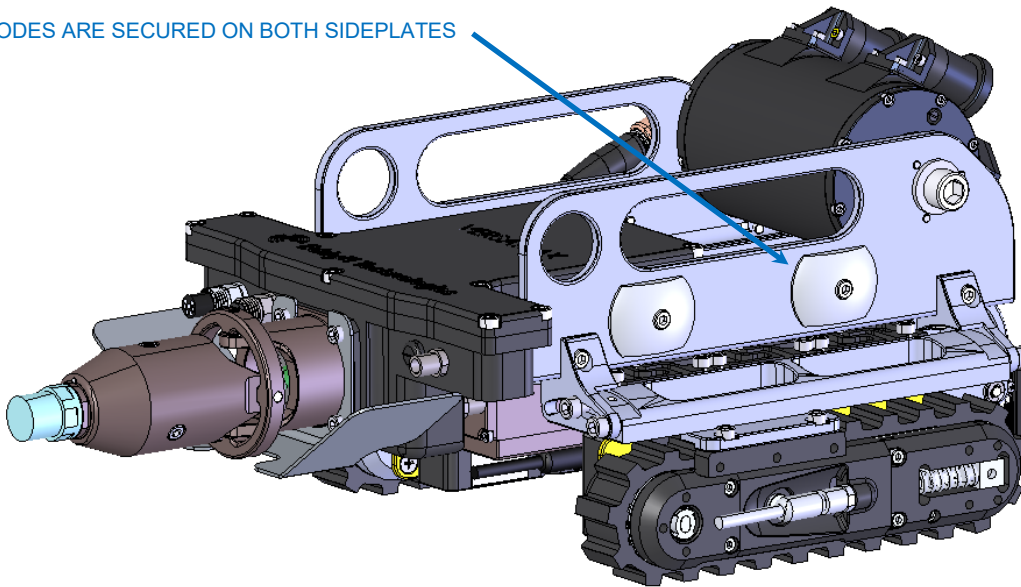

## Rinsing and Cleaning

After every mission check to see if the vehicle needs cleaning.

1. If the system has been used in salt water, thoroughly rinse the vehicle with fresh water prior to being stored away. Accelerated corrosion will result if the inspection system is not rinsed properly. Pay close attention to rinsing and cleaning the camera window, LED light dome and the spaces between moving parts and track belts.
2. Use an open hose or tap at regular water line pressure for rinsing. Do not pressure wash the equipment – water will be forced into the camera at these high pressures.
3. Avoid scratching the camera port. Use glass cleaner and a soft cloth to clean the port.



**CAUTION:** Do not use a pressure washer to clean the vehicle or system components. Very high-pressure water can push past seals and flood the components resulting in electrical damage or personal injuries.

Periodically:

1. Use a damp cloth or spray cleaner for the power supply / controller box. The box must never be sprayed down or immersed in water. Unplug the controller before cleaning.
2. For general cleaning of the cameras and tracks, use a mild detergent.

## Fuse Replacement

The controller and power supply contain panel mount fuses for both AC and DC voltages. These fuses are for the safety of the operator(s) as well as to protect the equipment from damage. If a fuse blows, stop and look for possible causes. Causes might include cable damage, water incursion or improper connections. *See the controller manual for fuse replacement.*

Fuse values have been carefully selected for their application. Always replace the fuses with the same type and rating.



**Caution:** Disconnect the power source before checking or replacing fuses.

## Microtrac™ Maintenance

Refer to the Microtrac user manual for maintenance and servicing instructions.

## Tether Re-termination

Tether termination is a specialized service beyond the scope of this manual. Contact Eddyfi Technologies if the tether is damaged or requires re-termination.

Document: UMED021776.docm	Revision: A03	Created by: SR	Date: 07-Jan-2026	IPN: 3117437-A03
Source Location:				Page 30 of 34

## Troubleshooting

### Camera Control Problems

1. Not all the auxiliary lights are on.
  - The ICON™ software allows the lights to be controlled independently. Ensure all lights are enabled. Refer to the ICON interface manual.
  - Inspect for blown LEDs.
2. Camera tilt does not function in one or both directions.
  - Check that the camera is not jammed.
  - If you can hear a motor running but see no movement, there is a mechanical or clutch problem inside the camera. Contact us.
3. Camera is moving very slowly.
  - Check the tilt speed in the camera control window. Refer to the ICON user interface manual.

### Video Issues

1. No video (black or blue background).
  - Interface box is not turned on.
  - Video cables are not hooked up between interface box and computer.
  - Camera connector on vehicle is loose (turn power off first before plugging in camera).
  - Check monitor input settings.
  - Vehicle power is not on.
  - Check for problems with other video components between the computer and monitor.
  - Try a different monitor.
2. Picture is very dark or very bright.
  - Check the light levels of both the camera and main lights.
3. Intermittent picture.
  - Check and replace the video cables. Faulty video cables are common.
  - Check that the monitor is working properly.
  - Check that the camera harness whip is fully plugged in.
  - Check for intermittent breaks in the camera harness cable.
  - Check the tether connectors at both controller and vehicle.
  - Check for tether or slip ring damage by testing tether continuity.
4. Picture is blurry, will not focus, or has poor color.
  - This may be a dirty camera view port, or a narrow object lying in front of the view port.
  - Object may be too close to the camera.

Document: UMED021776.docm	Revision: A03	Created by: SR	Date: 07-Jan-2026	IPN: 3117437-A03
Source Location:				Page 31 of 34

## Vehicle Issues

1. Vehicle will not steer, or vehicle runs backward.
  - Tracks may be set to the wrong positions.
  - Track reverse settings are incorrect in the control software.
  - A node ID conflict may exist between one or more devices on the vehicle.
  - The magnets may be positioned too close to the steel surface.
  
2. Tracks will not run.
  - Magnets may be too close to the steel surface.
  - Check the track current feedback (See ICON™ manual)
    - If the current is at 100% and the vehicle doesn't move, then the tracks may be jammed. They could be wedged on an object or jammed with sand. Try reversing the tracks to clear debris. If a jam won't clear you will have to recover the vehicle by pulling it out with the tether.
    - If no current is registered, then power or communication is not getting to the tracks. Check all the cable connections.
  - Try power cycling the system.
  - Inspect the vehicle wiring for damage.
  - Check all the system connectors.
  - Try restarting ICON.
  - Listen for the track motors. If the motors run but the track doesn't turn, there is a problem with the gearing or shaft pins.
  - Try changing tracks and updating the serial number configuration (ICON will require a restart).

## Tether Reel Issues

1. Tether distance does not read correctly.
  - Check that the pressure wheel is pressing the tether against the payout sheave. If the tether is being pulled up from the sheave instead of down, it may be disengaged from the sheave.
  - Check that the units are set properly in the graphical overlay.
  - Recalibrate distance encoder.
  - Ensure that the correct COM port is selected in the control software.
  
2. Intermittent problems with vehicle or camera, only when reel is turning.
  - The slip ring may be damaged. Use a multi-meter to check continuity of the tether with reel drum turning.

Document: UMED021776.docm	Revision: A03	Created by: SR	Date: 07-Jan-2026	IPN: 3117437-A03
Source Location:				Page 32 of 34

## Parts and Repairs

### Ordering Parts/Customer Service

Spare and/or replacement parts are available for your product and can be ordered directly from your local office.

When ordering parts always make sure to quote the sales order acknowledgement (SOA) number and/or the serial number of the system component in question.

Eddyfi Robotics Inc. (Canadian Headquarters and Manufacturing Location)  
 2569 Kenworth Road, Suite C  
 Nanaimo, BC, V9T 3M4  
 CANADA  
 TF 1.877.468.5886  
 T +1.250.729.8080  
 info@eddyfi.com  
 www.eddyfitechnologies.com

Eddyfi Technologies – US (American Authorized Distributor and Service Centre)  
 812 W 13th Street  
 Deer Park, TX, 77536  
 USA  
 T +1.281.542.3292  
 info@eddyfi.com  
 www.eddyfitechnologies.com

### Warranty Repairs

Warranty conditions are specified in the Warranty section. Should any conditions of the manufacturer's warranty be breached, the warranty may be considered void. All returned items must be sent prepaid to Eddyfi Technologies at the above address.

### Factory Returns to Canada

Some sub-assemblies of your Eddyfi Technologies product are not field-serviceable and may need to be returned to the factory for repair. Warranty claims must be returned to the factory for evaluation.

To return an item for evaluation or repair, first contact Eddyfi Technologies at our toll-free number or e-mail address. Eddyfi Technologies will supply a Return Merchandise Authorization (RMA) number with detailed shipping and customs instructions. Items shipped without an RMA number will be held at Eddyfi Technologies until the correct paperwork is completed. If cross-border shipments are not labelled as per the instructions, the items may be held by customs, and issued additional fees.

All returned items must be sent prepaid unless other specific arrangements have been made.

Document: UMED021776.docm	Revision: A03	Created by: SR	Date: 07-Jan-2026	IPN: 3117437-A03
Source Location:				Page 33 of 34

When the product or system is being shipped anywhere by courier or shipping company, it must be packaged in the original packaging it was received in. This measure greatly reduces the consequences of rough handling and subsequent shipping damage.

Eddyfi Technologies cannot be held responsible for damages due to improper packaging. Shipping damage may have a significant impact on repair turnaround times.

### Product/System Drawing Package Availability

Mechanical assembly and electrical wiring diagram drawing packages for your equipment are available in PDF format upon request. Printed copies may also be purchased from Eddyfi Technologies. Contact your local sales contact for more information.

### Limited Warranty Policy

Refer to the Eddyfi Technologies website for warranty terms for this product.

<https://www.eddyfi.com/en/salesterms>

Document: UMED021776.docm	Revision: A03	Created by: SR	Date: 07-Jan-2026	IPN: 3117437-A03
Source Location:				Page 34 of 34