



Advanced Test Equipment Corp.

www.atecorp.com 800-404-ATEC (2832)

A.H. Systems SAS-571 Double Ridge Guide Horn Antenna

SAS-571 Double Ridge Guide Horn Operation Manual

TABLE OF CONTENTS

INTRODUCTION

<i>Introduction</i>	3
<i>Intended Purposes</i>	4
<i>Optional Equipment</i>	5

OPERATING INSTRUCTIONS

<i>Assembly Instructions</i>	6
<i>Mounting Instructions</i>	6
<i>Operating Instructions</i>	6

SPECIFICATIONS

<i>Specifications</i>	8
<i>Typical Data</i>	9
<i>Calculations</i>	11
<i>Conversion Factors</i>	12

MAINTENANCE

<i>Maintenance Procedures</i>	13
<i>Annual Calibration</i>	13
<i>Warranty</i>	14

INTRODUCTION

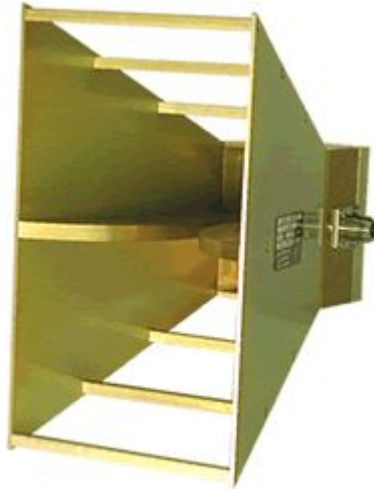

The SAS-571 Double Ridge Guide Horn Antenna is lightweight, compact and has been manufactured for maximum gain, low VSWR and broadband response. The double ridge guide horn antenna was initially designed for surveillance where a high gain broadband response was required. The original design was to have a 30-degree beamwidth, which is ideal for EMI measurements and compliance testing.

GENERAL DESCRIPTION

The SAS-571 Double Ridge Guide Horn Antenna mounts directly to the tripod azimuth and elevation head (AEH-510) at the base of the antenna. The azimuth and elevation head allows the operator to vary the antenna azimuth (left right direction) and elevation (up, down direction) and makes it easy to change the antenna polarity (horizontal or vertical).

To obtain the field strength of the signal being measured, the operator must add the receiver reading in dBuV, the antenna factor in dB, and the cable attenuation in dB. This yields the field strength in dBuV/m. Calibrations for the E-field antennas are supplied at appropriate spacings (1, 3, and 10 meter) to comply with various specification requirements.

INTENDED PURPOSES

The double ridge guide horn antenna is intended for general laboratory use in a wide variety of industrial and scientific applications. It has been designed to be used in the process of generating, controlling and measuring high levels of electromagnetic Radio Frequency (RF) energy. It is the responsibility of the user to assure that the device is operated in a location which will control the radiated energy such that it will not cause injury and will not violate regulatory levels of electromagnetic interference.

OPTIONAL EQUIPMENT

The following is a recommend accessory list for the SAS-571 Double Ridge Guide Horn Antenna:

CONNECTING ACCESSORIES:

PAM-0118

This preamplifier has a broad frequency range and high gain, designed to match the double ridge guide horn antenna. An ideal solution for improving overall system sensitivity.

SAC-18G-3

Our Low-Loss High-Frequency flexible cables are the preferred choice over standard cable types. With improved power handling, low VSWR, and high frequency capabilities, the Low-Loss cables can be made to your specified length

MOUNTING ACCESSORIES:

AEH-510

Azimuth and elevation head is used to assist the test engineer in orientating the horn antenna towards the device under test.

ATU-510

Each tripod leg is independently adjustable in angle and length to facilitate antenna height setting. The tripod legs have a rubber tip on one end for indoor or hard surface use, and a metal spike on the other end for outdoor soft surface (such as dirt) use.

OPERATING INSTRUCTIONS

ASSEMBLY INSTRUCTIONS

The SAS-571 Horn antenna comes with a 3" mounting bracket and thumbscrew. The mounting bracket is attached to the antenna backwards for packing purposes. The bracket must be removed from the antenna, turned over (so that the bracket leg faces away from the antenna), and re-attached to the antenna. This mounting bracket will allow the antenna to be mounted directly on top of the tripod.

MOUNTING INSTRUCTIONS

Attach the antenna to a tripod or mast with the 1/4-20 threaded hole in the mounting bracket. The location of the rear screw makes it easy to rotate the antenna from horizontal to vertical polarization. For horizontal polarization, mount the antenna such that the ridge guides and connector are parallel to the ground. For vertical polarization, mount the antenna such that the ridge guides are perpendicular to the ground.

The SAS-571 double ridge guide Horn antenna also has a rear 1/4-20 threaded insert to allow attachment directly in the center of the antenna. Caution should be used when mounting the antenna with the rear 1/4-20 threaded hole. The hole is only 1/2" deep, and puncturing the shorting plate will adversely effect the antenna response.

The SAS-571 horn antenna has a beamwidth of 48 degrees and it should be pointed or aimed in the direction that the received signal is coming from. The measurement reference point is at the aperture of the antenna for all distances.

OPERATING INSTRUCTIONS

Once the antenna is mounted to a mast or tripod, connect a N-type coaxial cable from the Double Ridge Guide Horn antenna to a receiver or RF generator. The cable should be matched to 50 ohms, and It is recommended to use a high-frequency low-loss cable (i.e. SAC-18G-3 Low Loss cable). For certain applications where an increased dynamic range is required, an optional preamplifier (PAM-0118) may be used to increase the total system sensitivity.

CAUTION: Even though the horn antenna does not have any ESD concerns, touching the horn antenna while connected to a sensitive preamplifier may cause damage to that device.

The double ridge guide horn antenna is in the horizontal polarization when the ridge guides are parallel to the ground, and vertical polarization when the ridge guides are perpendicular to the ground.

To minimize impedance mismatch errors, it is recommended that high-quality in-line attenuators be used to reduce reflections. Connect the attenuator at the antenna end of the transmitting cable, or when receiving connect the attenuator at the measuring instrument or preamplifier input.

SPECIFICATIONS

The SAS-571 Horn Antenna specifications:

ELECTRICAL

Frequency Range	700 MHz - 18 GHz
Antenna Factor.....	22 to 44 dB/m
Average Gain	12 dBi
Maximum Continuous Power.....	300 Watts
Peak Power.....	500 Watts
Average Beamwidth (E-Field).....	48°
Average Beamwidth (H-Field)	30°
Impedance (nominal).....	50 Ω
Average VSWR.....	1.5:1
Maximum Radiated Field:	200 V/m
Connector:	N-type (female)
Mounting	1/4-20 (female)

MECHANICAL

Weight	3.5 lbs.
.....	(1.59 Kg)
Size (W x H x D).....	11" x 5.6" x 9.6"
.....	28cm x 14.cm x 24.4cm

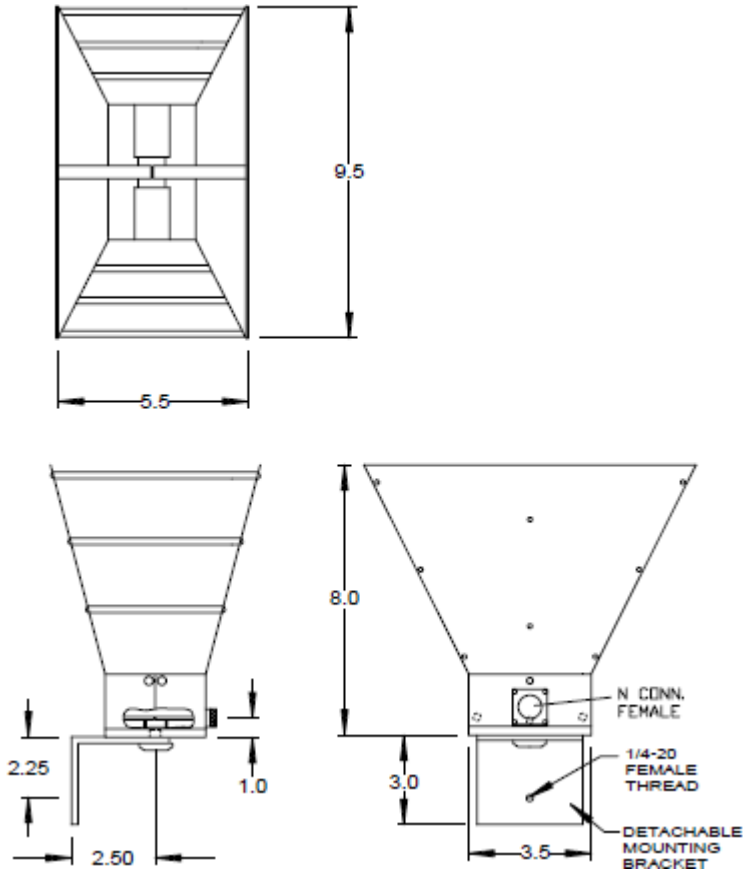

TYPICAL DATA



A.H. Systems Inc.
9710 Cozycroft Ave. Chatsworth, CA 91311
Phone (818) 998-0223 Fax (818) 998-6892
E-mail: sales@AHSystems.com
Web site: <http://www.AHSystems.com>

**Double Ridge Guide
Horn Antenna
Model: SAS-571**

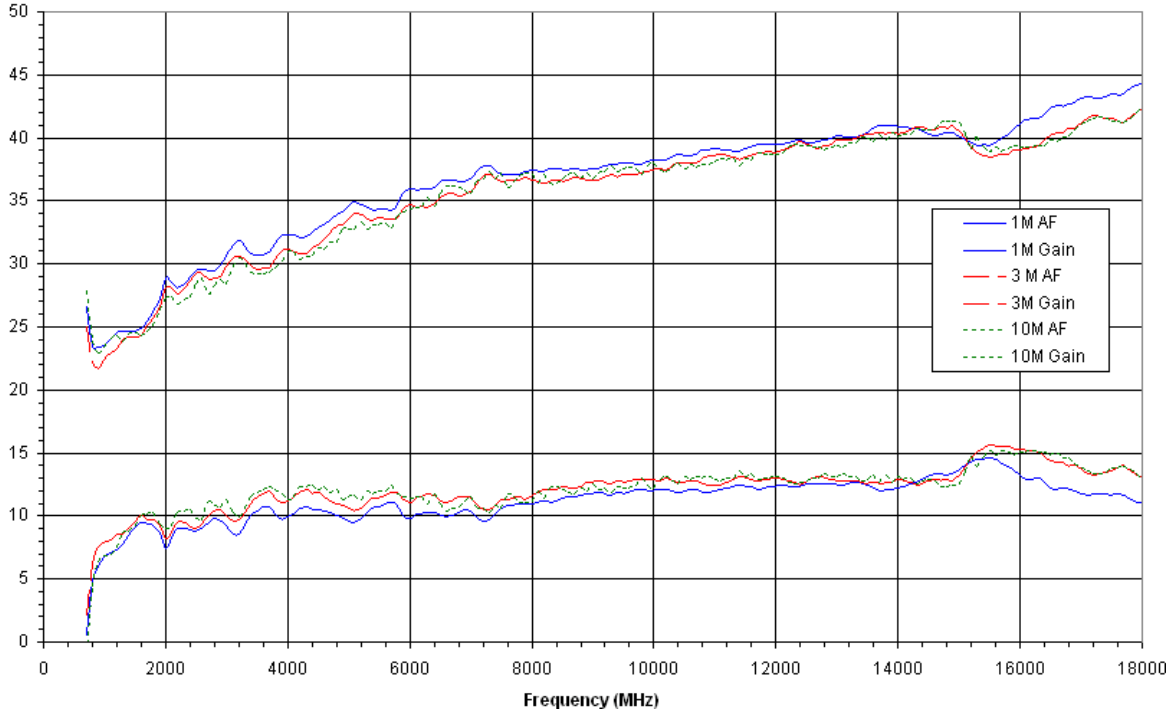

A.H. Systems Inc.
9710 Cozycroft Ave. Chatsworth, CA 91311
Phone (818) 998-0223 Fax (818) 998-6892
E-mail: info@AHSystems.com
Web site: <http://www.AHSystems.com>

**VSWR
Double Ridge Guide Horn Antenna
Model SAS-571**

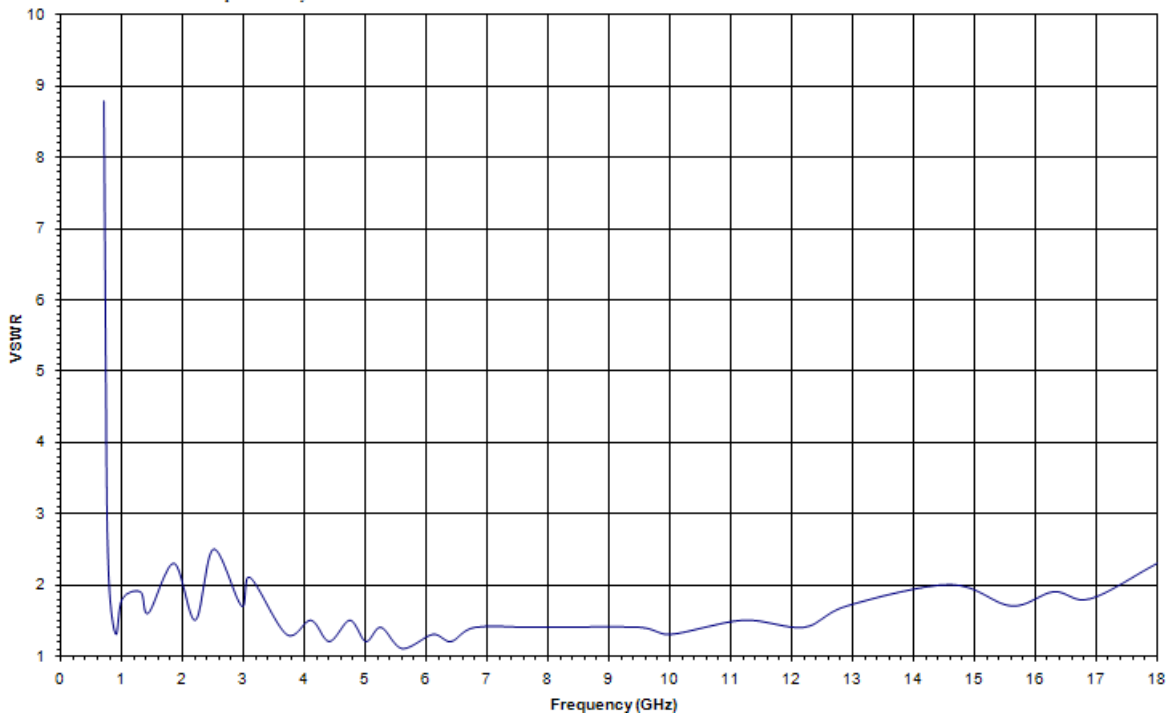

CALCULATIONS

EMISSIONS TESTING

Individual calibration data for the double ridge guide horn antenna is supplied at appropriate distances (3 and 10 meter) to comply with various emissions test requirements. For emissions measurements, add antenna factor plus cable loss to receiver reading in dB μ V to convert to field strength in dB μ V/meter.

FS = Field Strength in dB μ V/m

$$FS \text{ (dB}\mu\text{V/m)} = SA \text{ (dB}\mu\text{V)} + AF\text{(dB)} + CL \text{ (dB)}$$

SA = Spectrum Analyzer or Receiver voltage reading

AF = Antenna Correction Factor

CL = Cable Loss in dB

IMMUNITY TESTING

For Immunity measurements, the generated electric field strength can be calculated by:

FS = Approximate Field Strength in (V/m)

$$FS \text{ (V/m)} = \frac{\sqrt{30Pg}}{d}$$

P = Power in watts

g = Numeric Gain

d = Distance in meters

TYPICAL CONVERSION FORMULAS

LOG -> LINEAR VOLTAGE

dB μ V to Volts	$V = 10^{((dB\mu V - 120) / 20)}$
Volts to dB μ V	$dB\mu V = 20 \log(V) + 120$
dBV to Volts	$V = 10^{(dBV / 20)}$
Volts to dBV	$dBV = 20 \log(V)$
dBV to dB μ V	$dB\mu V = dBV + 120$
dB μ V to dBV	$dBV = dB\mu V - 120$

LOG -> LINEAR CURRENT

dB μ A to μ A	$\mu A = 10^{(dB\mu A / 20)}$
μ A to dB μ A	$dB\mu A = 20 \log(\mu A)$
dBA to A	$A = 10^{(dBA / 20)}$
A to dBA	$dBA = 20 \log(A)$
dBA to dB μ A	$dB\mu A = dBA + 120$
dB μ A to dBA	$dBA = dB\mu A - 120$

LOG -> LINEAR POWER

dBm to Watts	$W = 10^{((dBm - 30) / 10)}$
Watts to dBm	$dBm = 10 \log(W) + 30$
dBW to Watts	$W = 10^{(dBW / 10)}$
Watts to dBW	$dBW = 10 \log(W)$
dBW to dBm	$dBm = dBW + 30$
dBm to dBW	$dBW = dBm - 30$

TERM CONVERSIONS

dBm to dB μ V	$dB\mu V = dBm + 107$ (50 Ω) $dB\mu V = dBm + 10 \log(Z) + 90$
dB μ V to dBm	$dBm = dB\mu V - 107$ (50 Ω) $dBm = dB\mu V - 10 \log(Z) - 90$
dBm to dB μ A	$dB\mu A = dBm - 73$ (50 Ω) $dB\mu A = dBm - 10 \log(Z) + 90$
dB μ A to dBm	$dBm = dB\mu A + 73$ (50 Ω) $dBm = dB\mu A + 10 \log(Z) - 90$
dB μ A to dB μ V	$dB\mu V = dB\mu A + 34$ (50 Ω) $dB\mu V = dB\mu A + 20 \log(Z)$
dB μ V to dB μ A	$dB\mu A = dB\mu V - 34$ (50 Ω) $dB\mu A = dB\mu V - 20 \log(Z)$

FIELD STRENGTH & POWER DENSITY

dB μ V/m to V/m	$V/m = 10^{(((dB\mu V/m) - 120) / 20)}$
V/m to dB μ V/m	$dB\mu V/m = 20 \log(V/m) + 120$
dB μ V/m to dBmW/m ²	$dBmW/m^2 = dB\mu V/m - 115.8$
dBmW/m ² to dB μ V/m	$dB\mu V/m = dBmW/m^2 + 115.8$
dB μ V/m to dB μ A/m	$dB\mu A/m = dB\mu V/m - 51.5$
dB μ A/m to dB μ V/m	$dB\mu V/m = dB\mu A + 51.5$
dB μ A/m to dBpT	$dBpT = dB\mu A/m + 2$
dBpT to dB μ A/m	$dB\mu A/m = dBpT - 2$
W/m ² to V/m	$V/m = \text{SQRT}(W/m^2 * 377)$
V/m to W/m ²	$W/m^2 = (V/m)^2 / 377$
μ T to A/m	$A/m = \mu T / 1.25$
A/m to μ T	$\mu T = 1.25 * A/m$

E-FIELD ANTENNAS

Correction Factor	$dB\mu V/m = dB\mu V + AF$
Field Strength	$V/m = \sqrt{\frac{30 * \text{watts} * \text{Gain}_{\text{numeric}}}{\text{meters}}}$
Required Power	$\text{Watts} = \frac{(V/m * \text{meters})^2}{30 * \text{Gain}_{\text{numeric}}}$

LOOP ANTENNAS

Correction Factors	$dB\mu A/m = dB\mu V + AF$
Assumed E-field for shielded loops	$dB\mu V/m = dB\mu A/m + 51.5$
	$dBpT = dB\mu V + dBpT/\mu V$

CURRENT PROBES

Correction Factor	$dB\mu A = dB\mu V - dB_{(ohm)}$
Power needed for injection probe given voltage(V) into 50 Ω load and Probe Insertion Loss (I _L)	$\text{Watts} = 10^{((I_L + 10 \log(V^2/50)) / 10)}$

MAINTENANCE

MAINTENANCE PROCEDURES

Proper antenna maintenance should include:

- Visual inspection of RF connectors
- Check for loose or missing hardware
- Check for corrosion near the joints

At least once a month it is a good idea to wipe down the antenna with a damp rag.

ANNUAL CALIBRATION

To ensure reliable and repeatable long-term performance, annual re-calibration of your antennas, preamplifiers and current probes by A.H. Systems experienced technicians is recommended. Our staff can calibrate almost any type or brand of antenna.

It is always up to the user to determine the appropriate interval for calibration certification based on the requirements of the end users specific test/application. The calibration of EMC antennas is important for those conforming to compatibility standard. Radiated emissions testing for electromagnetic compatibility (EMC) requires the measurement of electric field (E-field) strength, which is compared with a limit level. The output voltage of an antenna is converted to E-field strength via its antenna factor, the measurement of which must include the uncertainty components related to that particular antenna, taking into consideration the environment in which the antenna is to be used for the testing. Most standards will specify the appropriate interval for re-calibration of your EMC antenna.

In some cases these antennas are used for a manufacturers pre-compliance testing, field monitoring, surveillance and/or other applications where the exact field intensity of the received signal is not of importance. For those customers a yearly re-calibration is not necessary, however it is recommended that an interval for maintenance be performed.

For more information about our calibration services or to place an order for antenna calibration visit our website at <http://www.AHSystems.com> or call 1(818) 998-0223.

WARRANTY INFORMATION

A.H. Systems Inc., warrants that our Antennas, Sensors and Probes will be free from defects in materials and workmanship for a period of three (3) years. All other products delivered under contract will be warranted for a period of two (2) years. A.H. Systems' obligation under this warranty shall be limited to repairing or replacing, F.O.B. Chatsworth, California, each part of the product which is defective, provided that the buyer gives A.H. Systems notice of such defect within the warranty period commencing with the delivery of the product by A.H. Systems.

The remedy set forth herein shall be the only remedy available to the buyer, and in no event shall A.H. Systems be liable for direct, indirect, incidental or consequential damages.

This warranty shall not apply to any part of the product which, without fault of A.H. Systems has been subject to alteration, failure caused by a part not supplied by A.H. Systems, accident, fire or other casualty, negligence, misuse or normal wear of materials.

Except for the warranty set forth above, there are no other warranties, expressed or implied, with respect to the condition of the product or its suitability for the use intended for them by the buyer.

For prompt service, please contact our service department for a Return Material Authorization Number before shipping equipment back to us.