



Advanced Test Equipment Rentals
www.atecorp.com 800-404-ATEC (2832)



Sorensen
SGL Series DC
Power Supplies
Operation Manual

FCC NOTICE

This equipment has been tested and found to comply with the limits for a Class A digital device, pursuant to part 15 of the FCC Rules. These limits are designed to provide reasonable protection against harmful interference when the equipment is operated in a commercial environment. This equipment generates, uses, and can radiate radio frequency energy and, if not installed and used in accordance with the instruction manual, may cause harmful interference to radio communications. Operation of this equipment in a residential area is likely to cause harmful interference in which case the user will be required to correct the interference at his own expense.

ABOUT THIS MANUAL

This manual has been written expressly for the Sorensen SGI Series of power supplies that have been designed and certified to meet the Low Voltage and Electromagnetic Compatibility Directive Requirements of the European Community.

Since the Low Voltage Directive is to ensure the safety of the equipment operator, universal graphic symbols have been used both on the unit itself and in this manual to warn the operator of potentially hazardous situations (see Safety Notice page).

CONTENTS

SECTION 1 OVERVIEW	1-1
1.1 General Description	1-1
1.2 Technical Specifications	1-1
1.2.1 Environmental Characteristics	1-2
1.2.2 Electrical Characteristics.....	1-2
1.2.3 SGI Series Voltage and Current Specifications	1-4
1.2.4 Physical Characteristics.....	1-4
SECTION 2 INSTALLATION	2-1
2.1 Inspection	2-1
2.2 Contents of Shipment	2-1
2.3 Location and Mounting	2-2
2.3.1 Rack.....	2-2
2.3.2 6U Chassis Removal from Rack	2-3
2.4 Input/Output Connections	2-3
2.5 Wire Selection.....	2-5
2.5.1 Wire Size.....	2-5
2.6 Load Considerations.....	2-8
2.6.1 Inductive Loads.....	2-8
2.7 Outline Drawings	2-9
2.8 Installation Drawings.....	2-12
SECTION 3 OPERATION	3-1
3.1 Introduction	3-1
3.2 Controls and Indicators.....	3-1
3.2.1 Front Panel	3-1

3.3	Initial Start-up and Displays	3-5
3.4	Display Elements	3-6
3.5	Navigation	3-6
3.6	Editing	3-8
3.6.1	Aborting an Edit	3-9
3.7	Menu Map	3-10
3.7.1	Home Menu	3-10
3.7.2	Default Programming Menu	3-10
3.7.3	Navigating from Home Menu Page 1	3-10
3.7.4	Navigating from Home Menu Page 2	3-11
3.7.5	Navigating from Home Menu Page 3	3-11
3.7.6	Sequence Menu	3-12
3.7.7	Sequence Programming Operation	3-12
3.7.8	Constant Power Setup Menu	3-13
3.7.9	Remote Menu	3-13
3.7.10	Remote Control Screen Examples	3-14
3.7.11	Warning Screens	3-14
3.7.12	Other Screens	3-14
3.8	Functions.....	3-14
3.8.1	Voltage, Current, and Overvoltage Protection Programming	3-14
3.8.2	Save	3-15
3.8.3	Recall	3-16
3.8.4	Sequencing	3-17
3.8.5	Power Mode	3-25
3.8.6	Home Timeout.....	3-26
3.8.7	Display Brightness.....	3-26
3.8.8	Lock Key.....	3-26
3.8.9	Language	3-26
3.8.10	Info	3-27
3.8.11	Remote.....	3-27
3.8.12	System	3-30
3.8.13	Warning Screens.....	3-31
3.9	Basic Operation and Output Verification	3-31
3.9.1	Initial Setup.....	3-31
3.9.2	Default Programming Menu	3-32
3.9.3	Floating and Polarized Output.....	3-34
3.9.4	Remote Analog (J1) Control.....	3-35

3.10	Remote Current Programming.....	3-39
3.10.1	Remote Current Programming Using Resistance.....	3-39
3.10.2	Remote Current Programming Using a 0-5 VDC or 0-10 VDC Voltage Source.....	3-40
3.11	Remote Voltage Programming	3-41
3.11.1	External Voltage Programming Using Resistance	3-41
3.11.2	External Voltage Programming Using a 0-5 VDC or 0-10 VDC Voltage Source.....	3-42
3.12	Remote Sensing	3-43
3.13	Remote Output On/Off Control	3-45
3.14	Remote Overvoltage Setpoint.....	3-46
3.15	Remote Shutdown (S/D).....	3-47
3.16	Parallel and Series Operation.....	3-48
3.16.1	Parallel Operation	3-48
3.16.2	Series Operation	3-50

SECTION 4 VERIFICATION AND CALIBRATION... 4-1

4.1	Introduction.....	4-1
4.1.1	Verification and Calibration Cycle	4-1
4.1.2	Preparation	4-1
4.2	Standard Verification and Calibration Procedure.....	4-2
4.2.1	Current Mode	4-3
4.2.2	Voltage Mode.....	4-3
4.2.3	Resistor Programming Current Sources	4-4
4.2.4	Change Calibration Date.....	4-5
4.3	Isolated Analog (Option) Verification and Calibration Procedure	4-5
4.3.1	Current Mode	4-5
4.3.2	Voltage Mode.....	4-6
4.3.3	Change Calibration Date.....	4-7

SECTION 5 MAINTENANCE 5-1

5.1	Introduction.....	5-1
5.2	Preventive Maintenance	5-1
5.3	Fuses.....	5-3

LIST OF TABLES

Table 2.1	5kW to 15kW and 20kW to 30kW Series Input/Output Connectors	2-4
Table 2.2	Input Connections.....	2-4

Table 2.3 Output Connections	2-4
Table 2.4 Minimum Wire Size	2-6
Table 2.5 Wire Resistance and Voltage Drop	2-7
Table 2.6 Maximum AC Current Ratings	2-7
Table 2.7 Recommended Lugs	2-8
Table 2.8 Recommended Sense Connector Tools	2-8
Table 3.1 Analog Control Connector (J1), Designations and Functions	3-38
Table 5.1 Recommended Annual Inspection	5-2
Table 5.2 Fuse Values	5-3

LIST OF FIGURES

Figure 1-1. Model Number Decoding	1-1
Figure 2-1. Diode Connection	2-9
Figure 2-2. SGI Unit Dimensions, 3U Model	2-10
Figure 2-3. SGI Series Outline Drawing, 6U Models, 20kW to 30kW	2-11
Figure 2-4. Rear Panel Input-Output Connector Locations	2-12
Figure 2-5. 800V Rear Panel Input-Output Connector Locations	2-13
Figure 2-6. SGI Detailed Chassis Dimensions for Installation	2-14
Figure 3-1. Front Panel Controls and Indicators	3-2
Figure 3-2. SG Rear Panel with GPIB Option	3-3
Figure 3-3. SG Rear Panel with Ethernet Option	3-4
Figure 3-4. Burn-in Sequence Example	3-22
Figure 3-5. Constant Power Example	3-25
Figure 3-6. Analog Control Connector (J1) Pin-out	3-36
Figure 3-7. Remote Current Programming Using Resistance	3-39
Figure 3-8. Remote Current Programming Using 0-5 VDC or 0-10 VDC Voltage Source	3-40
Figure 3-9. Remote Voltage Programming Using Resistance	3-41
Figure 3-10. Remote Voltage Programming Using 0-5 VDC or 0-10 VDC Voltage Source	3-42
Figure 3-11. Local/Remote Voltage Sensing	3-43
Figure 3-12. Remote Sensing Operation at the Load	3-44
Figure 3-13. Remote Output On/Off Control by Contact Closure	3-45
Figure 3-14. Remote Output On/Off Using Isolated AC or DC Voltage Source	3-45
Figure 3-15. Remote Output On/Off Using Isolated TTL/CMOS Voltage Supply	3-46
Figure 3-16. Remote Overvoltage Set Using DC Voltage Source	3-46
Figure 3-17. Remote Shutdown Using DC Voltage Source	3-47
Figure 3-18. Parallel and Remote/Local Sense Connections	3-49
Figure 4-1. Precision Current Shunt	4-2
Figure 4-2. Potentiometer Locations	4-8

This page intentionally left blank.

SECTION 1 OVERVIEW

1.1 General Description

The Sorensen SG Series power supplies are general-purpose power supplies designed specifically for laboratory test and systems applications requiring variable DC sources with good ripple and regulation characteristics. These power supplies are constant current/constant voltage supplies with an automatic crossover feature.

A variety of user interfaces are available, ranging from manual front-panel control and standard non-isolated remote analog control, to optional GPIB or isolated remote analog control.

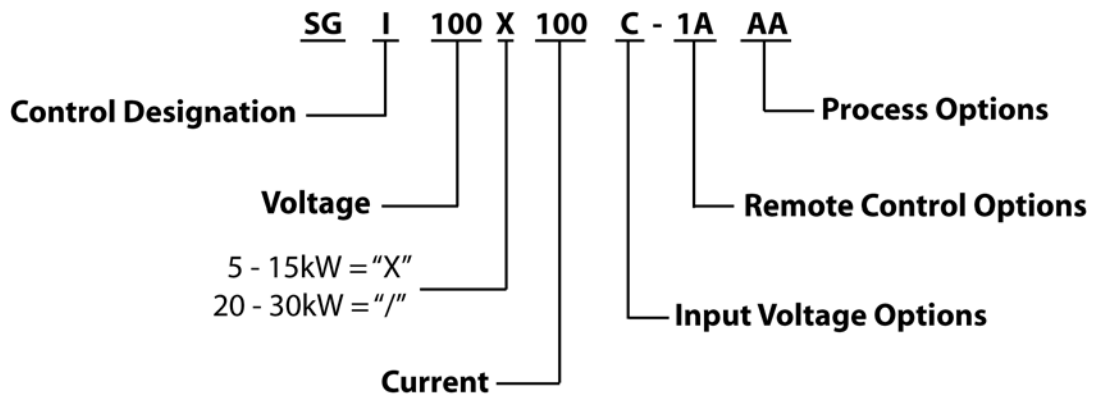

Figure 1-1. Model Number Decoding

1.2 Technical Specifications

The following subsections provide environmental, electrical, and physical characteristics for the SGI Series power supplies.

Note: Specifications are subject to change without notice.

Note: The SGI Series power supplies are intended for indoor use only. Please refer to Section 2.3 *Location and Mounting* for use/location requirements.

1.2.1 Environmental Characteristics

Parameter	Specification
Temperature Coefficient	0.02%/°C of maximum output voltage rating for voltage set point. 0.03%/°C of maximum output current rating for current set point.
Ambient Temperatures	
Operating	0 to 50°C
Storage	-25° to 65°C
Cooling	Internal fans; vents on sides and rear. (Units may be stacked without clearance above or below).
Humidity	95% maximum, non-condensing, 0 to 50°C; 45°C maximum wet-bulb temperature
Altitude	Operating full power available up to 5,000 feet (1,524m), derate 10% of full power for every 1,000 feet higher; non-operating to 40,000 feet (12,192m)
Ozone concentration	Recommended long-term exposure limit is 0.1 PPM (0.2 mg/m ³).
Agency Approvals	CE Marked to the Low Voltage and EMC directives. NRTL approved to UL1012, UL 61010, EN 61010, IEC 61010

1.2.2 Electrical Characteristics

The voltage accuracy specifications are valid only with remote sense connected.

Parameter	Specification
Input Power	
Voltage (Standard)	208/220 VAC±10% (tested to 187-242 VAC)
Voltage (Options)	380/400 VAC±10% (tested to 342-440 VAC) 440/480 VAC±10% (tested to 396-528 VAC)
Frequency	47 to 63 Hz
Phases	3-phase, 3-wire plus ground. Not phase rotation sensitive. Neutral not used.
Front Panel Meter Accuracy	
Voltage	±0.1% of full-scale
Current	±0.4% of full-scale
Load Regulation	
Voltage	0.02% of maximum output voltage
Current	0.1% of maximum output current
Line Regulation	
Voltage	0.01% of maximum output voltage
Current	0.05% of maximum output current
Transient Response	A 50% step load will recover to within 0.75% of original value within 1 ms.
Down Programming	With no load the output will program from 100 to 10% in less than 1.5 seconds
Stability	±0.05% of set point over 8 hours at fixed line, load, and temperature using remote sense and after 30 minute warm-up
Remote Control/Monitor	On/Off control via contact closure, 6-120 VDC or 12-240 VAC, and TTL or CMOS switch, output voltage and current monitor,

Parameter	Specification
	OVP limit set, summary fault status
Power Factor	>0.9 typical for 208/220VAC input >0.78 typical for 380/400VAC input >0.7 typical for 440/480VAC input
Efficiency	87% typical at full load, nominal line
Analog Remote Programming	
Accuracy	
Constant Voltage	±0.25% of full-scale output for 0-5V range (±0.5% 0-10V range)
Constant Current	±0.8% of full-scale output
Overvoltage Protection (OVP)	±1% of full-scale output
Resistive	
Constant Voltage (0-100%)	0–5 kΩ
Constant Current (0-100%)	0–5 kΩ
Voltage	
Constant Voltage (0-100%)	0–5 VDC or 0–10 VDC
Constant Current (0-100%)	0–5 VDC or 0–10 VDC
Overvoltage Protection (OVP) (5–110%)	0.25–5.5 VDC
Remote Sensing	Terminals are provided to regulate output voltage at point of load. Maximum line drop 5% of rated output voltage per line for 40-100V models, 2% of rated output voltage per line for >100V models.
ISOLATED ANALOG CONTROL (OPTION)	
Isolated Analog Control Input (J1) to Output Isolation	600 V Compliant with maximum terminal float voltage. Recommended operation under SELV normal conditions. (Standard Analog Control Input (J1) signals are referenced to the negative output terminal and are therefore not isolated from the output.)

1.2.3 SGI Series Voltage and Current Specifications

Voltage	Amperage						Noise** RMS	Noise* P-P
	5 kW	10 kW	15 kW	20 kW	25 kW	30 kW		
0-40V	0-125A	0-250A	0-375A	0-500A [†]	0-625A [†]	0-750 [†]	20 mV	75 mV
0-60V	0-83A	0-167A	0-250A	0-333A	0-417A	0-500A	20 mV	75 mV
0-80V	0-63A	0-125A	0-188A	0-250A	0-313A	0-375A	20 mV	100 mV
0-100V	0-50A	0-100A	0-150A	0-200A	0-250A	0-300A	20 mV	100 mV
0-160V	0-31A	0-63A	0-94A	0-125A	0-156A	0-188A	25 mV	150 mV
0-200V	0-25A	0-50A	0-75A	0-100A	0-125A	0-150A	25 mV	175 mV
0-250V	0-20A	0-40A	0-60A	0-80A	0-100A	0-120A	30 mV	200 mV
0-330V	0-15A	0-30A	0-45A	0-61A	0-76A	0-91A	30 mV	200 mV
0-400V	0-12A	0-25A	0-38A	0-50A	0-63A	0-75A	40 mV	300 mV
0-600V	0-8A	0-17A	0-25A	0-33A	0-42A	0-50A	60 mV	350 mV
0-800V	0-6.2A	0-12.5A	0-18.7A	0-25A	0-31.2A	0-37.5A	80 mV	500 mV

* P-P noise is measured across a 1 uF capacitor at the end of a 6' load cable with the supply operating at full load and at nominal input line voltage.

** RMS noise is measured directly across the output terminals with the supply operating at full load and at nominal input line voltage.

† Power level not available in 6U chassis. In 3U chassis, these power levels can be achieved up to 75kW by paralleling up to five power supplies. Note that paralleling will increase Ripple and Noise.

1.2.4 Physical Characteristics

Dimension	3U Models	6U Models
Width	19.00 in (48.3 cm)	19.00 in (48.3 cm)
Depth	25.46 in (64.7 cm)	25.12 in (63.8 cm)
Height	5.25 in (13.3 cm)	10.5 in (26.7 cm)
Weight	(5kW) ≈ 40 lbs (18 kg)	(20 kW) ≈ 120 lbs (54 kg)
	(10kW) ≈ 60 lbs (27 kg)	(25 kW) ≈ 140 lbs (64 kg)
	(15kW) ≈ 80 lbs (36 kg)	(30kW) ≈ 160 lbs (73 kg)

SECTION 2 INSTALLATION

2.1 Inspection

Inspect the shipping carton for possible damage before unpacking the unit. Carefully unpack the equipment. Save all packing materials until inspection is complete. Verify that all items listed on the packing slips have been received. Visually inspect all exterior surfaces for broken knobs, connectors, or meters. Inspect for dented or damaged exterior surfaces. External damage may be an indication of internal damage. If any damage is evident, immediately contact the carrier that delivered the unit and submit a damage report. Failure to do so could invalidate future claims. Direct repair issues to Customer Service at 858-458-0223 (local) or 1-800-733-5427 (toll free in North America).

2.2 Contents of Shipment





Depending on the model, configuration, and options available for your SGI Series power supply, the ship kit may include additional parts and accessories. At a minimum, the ship kit that accompanies your SGI Series power supply includes the following items:

- AMETEK Manuals CD-ROM, Part No. M550008-01 containing the SGI Series DC Power Supplies Operation Manual, Part No. M550221-01 (this manual), and the SG Series IEEE 488.2/RS232 Option and Ethernet Option Programming Manual, Part No. M550129-03.
- Sense mating connector (Molex P/N 39-01-4031) with loose contacts (Molex P/N 39-00-0182)
- J1 mating connector (Cinch P/N DB25P or equivalent) normally shipped attached to rear panel J1
- Back shell for J1 (DB25) mating connector (Cinch P/N DCH-B-001 or equivalent)

- Bolt, lock washer, and nut for output power connections as follows:
20–30 kW: $\frac{3}{8}$ -16UNC-2B x $\frac{7}{8}$ ", 4 ea for AC input and 2 ea for DC output
- Black screw, 10-32UNC-2B x $\frac{1}{2}$ ", front panel rack fastener:
5–15 kW: 4 ea
20–30 kW: 8 ea

Note: If any of these parts are missing, please contact Customer Service at 858-458-0223 (local) or 1-800-733-5427 (toll free).

2.3 Location and Mounting

	WARNING! To reduce the risk of fire or electrical shock, install the SGI Series unit in a temperature and humidity controlled indoor area, free of conductive contaminants.
	CAUTION! The unit should be provided with proper ventilation. The rear and both sides of the unit should be free of obstructions. To ensure proper airflow, a minimum 4" clearance from the rear air outlet is required. The unit should not be installed in a raised ambient temperature greater than 50°C.
	CAUTION! This unit is intended for installation in a protected environment. No user serviceable parts inside. Service to be performed by qualified personnel only.
	CAUTION! Ensure that the concentration of ozone is limited to a safe value. The recommended long-term exposure limit for ozone is 0.1 PPM (0.2 mg/m ³).

Please refer to Sections 2.7 and 2.8 for dimensional and installation drawings.

2.3.1 Rack

The SGI Series models are designed for mounting in a standard 19-inch equipment rack. If additional instrumentation is mounted in the rack, no additional clearance is required above or below units in the SGI series.

1. Support the unit by using rack mount slides or appropriate L-brackets. Suggested parts are listed as follows:

Rack Mount Slide Kit:

- 5–15kW units: P/N K550212-01
- 20–30kW units: P/N K550213-01

2. Secure the unit in place using the screws provided.

2.3.2 6U Chassis Removal from Rack

The slides have a Front Disconnect Feature and lock at full extension.

To return chassis back into rack from locked full extension, depress the flat steel spring inward (located on the slides) and push chassis back.



WARNING!

The 6U SGI Series unit weighs up to 160 lbs (73kg) depending on the model. A minimum three-person lift is required!

To disconnect and remove chassis from rack, depress the flat steel spring inward (located on the slides) and pull chassis forward.

When the chassis is at full extension, the flat springs are located approximately one (1) inch behind the front EIA RETMA rails. Access the springs with a flat blade screwdriver or similar device, to release from full-extension lock-out or to remove the chassis from the rack.

The slides can be mounted to the chassis with this spring oriented on the top or the bottom of the slide.

2.4 Input/Output Connections



WARNING!

High voltage present! Risk of electrical shock. Do not remove cover. Refer to qualified service personnel.

For permanently connected equipment, incorporate a readily accessible disconnect device in the fixed wiring. For pluggable equipment, install the socket outlet near the equipment in an easily accessible location.

Table 2.1 lists all external input/output connections and their functions for the SGI Series models. Table 2.2 and Table 2.3 provide input and output connection descriptions by power supply type. Section 2.8 shows installation drawings with input/output connector locations.



CAUTION!

Proper connection to the mains requires a circuit breaker or fuse with a rating at 25% over the maximum input line currents listed in Table 2.6.



WARNING!

Under no condition should the negative output terminal exceed 300V to earth ground.



CAUTION!
 Floating the negative output terminal floats the power supply's internal control circuitry common level to the same potential as the negative output terminal. On a standard non-isolated supply the common of the analog control connector (J1) floats at the same potential as the negative output terminal. Damage may occur if the non-isolated analog control connector of a supply is connected to an external ground referenced input/output device. Such a connection creates ground loop currents. To correct ground loop problems the Isolated Analog option is advised in order to isolate the external ground reference signals from the internal control circuitry of the supply.

Connector	Function	Connects To
FL1 – AC FL1 – AC FL1 – AC Chassis - GND	Prime AC Power Input See Table 2.2. Not phase rotation sensitive. Neutral not used.	208/220 VAC (Std) 380/400 VAC (Option) 440/480 VAC (Option) 47-63 Hz
Pos. Bus Bar Neg. Bus Bar Pos. Bus Bar Neg. Bus Bar	Output Power: 3U models (see Table 2.3) 6U models (see Table 2.3)	User load(s)
ANALOG CONTROL Connector (J1)	Control Interface	See Table 3.1 for description
Sense Connector	Used for remote sense	Refer to Section 3.12
Parallel In-Out	Used for parallel operation	Refer to Section 3.16

Table 2.1 5kW to 15kW and 20kW to 30kW Series Input/Output Connectors

Power Supply Type	Connection Description
5 kW to 15 kW	Feed-through high current terminal blocks
20 kW to 30 kW	Bus Bar with holes for 3/8"–16 bolts

Table 2.2 Input Connections

Power Supply Type	Connection Description
5 kW to 15 kW	Bus Bar with holes for 3/8" bolts Bronze studs, ¼-20 (800V model only)
20 kW to 30 kW	Bus Bar with holes for 3/8" bolts Bronze studs, ¼-20 (800V model only)

Table 2.3 Output Connections

**CAUTION!**

Prevent damage to the unit: follow torque specifications, use correct size wire ferrule (if used), and proper size ferrule crimping tool.

TORQUE SPECIFICATIONS

- The unit's Phoenix Connectors require 18 in-lb to 20 in-lb (2 Nm to 2.3 Nm) torque.
- Wire ferrules are recommended; their size must match the wire gauge.
- Crimp tool size must be appropriate to the ferrule size.
- Wire insulation should be stripped back no more than 5/8 inch for the ferrule.

For more information on this AC input connector, please look up Phoenix Contact part number HDFKV 16 at www.phoenixcontact.com.

2.5 Wire Selection

Care must be taken to properly size all conductors for the input and output of the power supply. This section provides guidance in the selection of wire size. Note that cables with Class B or C stranding should be used. Fine stranded cables should not be used unless crimp-on lugs or ferrules are used that are approved for fine stranded cables.

2.5.1 Wire Size

The tables below will assist in determining the appropriate wire size for both the input and output connections. Table 2.4 below gives *minimum* recommended wire size. This table is derived from the National Electrical Code; it is for reference only. Local laws and conditions may have different requirements. Note that these recommendations are for copper wire only. For higher ratings, wires can be paralleled; refer to the National Electrical Code.

Size	Temperature Rating of Copper Conductor			
	60°C	75°C	85°C	90°C
AWG MCM	Types: RUW, T, TW, UF	Types: FEPW, RHW, RH, RUH, THW, THWN, XHHW, USE, ZW	Types: V, MI	Types: TA, TBS, SA, AVB, SIS, FEP, FEPB, RHH, THHN, XHHW
	Current Rating			
14	20	20	25	25
12	25	25	30	30
10	30	35	40	40

Size	Temperature Rating of Copper Conductor			
	60°C	75°C	85°C	90°C
AWG MCM	Types: RUW, T, TW, UF	Types: FEPW, RHW, RH, RUH, THW, THWN, XHHW, USE, ZW	Types: V, MI	Types: TA, TBS, SA, AVB, SIS, FEP, FEPB, RHH, THHN, XHHW
	Current Rating			
8	40	50	55	55
6	55	65	70	75
4	70	85	95	95
3	85	100	110	110
2	95	115	125	130
1	110	130	145	150
0	125	150	165	170
00	145	175	190	195
000	165	200	215	225
0000	195	230	250	260

Table 2.4 Minimum Wire Size

When determining the optimum cable specification for your power applications, the same engineering rules apply whether going into or out of an electrical device. Thus, this guide applies equally to the input cable and output cable for this Sorensen instrument and application loads.

Power cables must be able to safely carry maximum load current without overheating or causing insulation destruction. It is important to everyday performance to minimize IR (voltage drop) loss within the cable. These losses have a direct effect on the quality of power delivered to and from instruments and corresponding loads.

When specifying wire gauge, consider the operating temperature. Wire gauge current capability and insulation performance drops with the increased temperature developed within a cable bundle and with increased environmental temperature. Thus, short cables with generously derated gauge and insulation properties are recommended for power source applications.

Be careful when using published commercial utility wiring codes. These codes are designed for the internal wiring of homes and buildings and accommodate the safety factors of wiring loss, heat, breakdown insulation, aging, etc. However, these codes consider that up to 5% voltage drop is acceptable.

Such a loss directly detracts from the quality performance specifications of this Sorensen instrument. Also, consider how the wiring codes apply to bundles of wire within a cable arrangement.

In high performance applications requiring high inrush/ transient currents,

additional consideration is required. The cable wire gauge must consider peak voltages and currents, which may be up to ten times the average values. An underrated wire gauge adds losses, which alter the inrush characteristics of the application and thus the expected performance.

Table 2.5 presents wire resistance and resulting cable voltage drop at maximum rated current.

Column 1	Column 2	Column 3	Column 4
Size (AWG)	Amperes (Maximum)	Ohms/100 Feet (One Way)	Voltage Drop/100 Feet (Column 2 x Column 3)
14	20	0.257	5.14
12	25	0.162	4.05
10	30	0.102	3.06
8	40	0.064	2.56
6	55	0.043	2.36
4	70	0.025	1.75
2	95	0.015	1.42
1/0	125	0.010	1.25
3/0	165	0.006	1.04

Table 2.5 Wire Resistance and Voltage Drop

Refer to Table 2.6 for AC input current requirements and Section 1.2.3 for output current requirements.

Input V	Input Line Current						Unit of Measure
	5 kW	10 kW	15 kW	20 kW	25 kW	30kW	
200-240VAC	21	41	62	83	103	124	Amps AC per phase
360-440VAC	14	27	40	54	67	80	
480VAC	13	26	39	52	65	78	

Table 2.6 Maximum AC Current Ratings

Refer to Table 2.7 for input/output lug recommendations.

Lug Manufacturer	3U Models Input/Output	6U Models Input/Output
Panduit	"PN" Series or equivalent "LCAN" Series for higher current	"LCA" Series or equivalent
Note: Contact lug manufacturer for recommended crimping tool.		

Table 2.7 Recommended Lugs

The recommended tools for crimping and extraction of the sense connector pins are listed below in Table 2.8.

Tool	Manufacturer	Manufacturer P/N
Crimping	Molex	11-01-0197
Extracting	Molex	11-03-0044

Table 2.8 Recommended Sense Connector Tools

2.6 Load Considerations

This section provides guidelines for using properly rated diodes to protect the power supply from damage while driving inductive loads.

2.6.1 Inductive Loads

To prevent damage to the power supply from inductive kickback, connect a diode (rated at greater than the supply's output voltage and current) across the output. Connect the cathode to the positive output and the anode to return. Where positive load transients such as back EMF from a motor may occur, a second diode in series with the output is recommended to protect the power supply.

BLOCKING AND FREE WHEELING DIODES

The Peak Reverse Voltage ratings should be a minimum of 2-3 times the Power Supply maximum output voltage. The Continuous Forward Current ratings should be a minimum of 1.5 times the Power Supply maximum output current. Heat sink may be required. There also may be a need for higher voltage rated parts, dependent on load circuit design and inductor values.

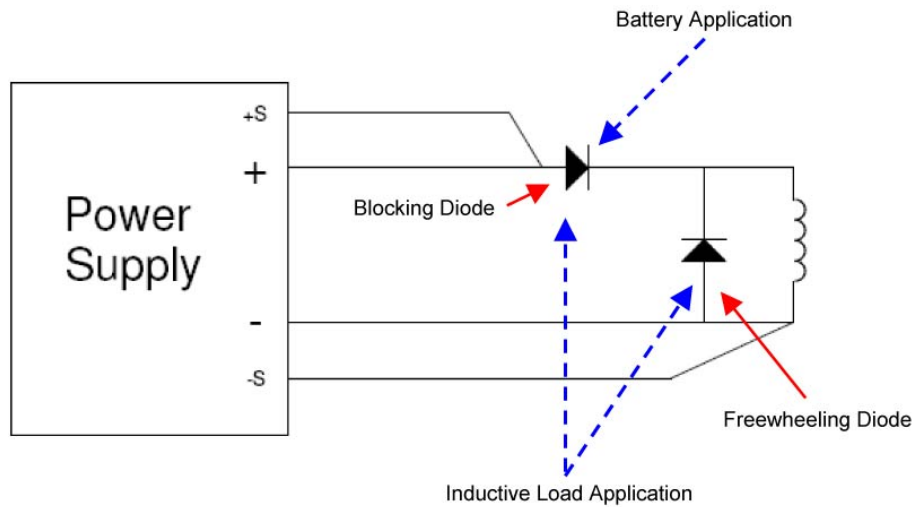

Figure 2-1. Diode Connection

2.7 Outline Drawings

Figure 2-2 and Figure 2-3, next, show the outlines and overall dimensions of the 3U and 6U models of the SGI Series product line. Figure 2-4, Figure 2-5, and Figure 2-6 provide detailed information for installation purposes.

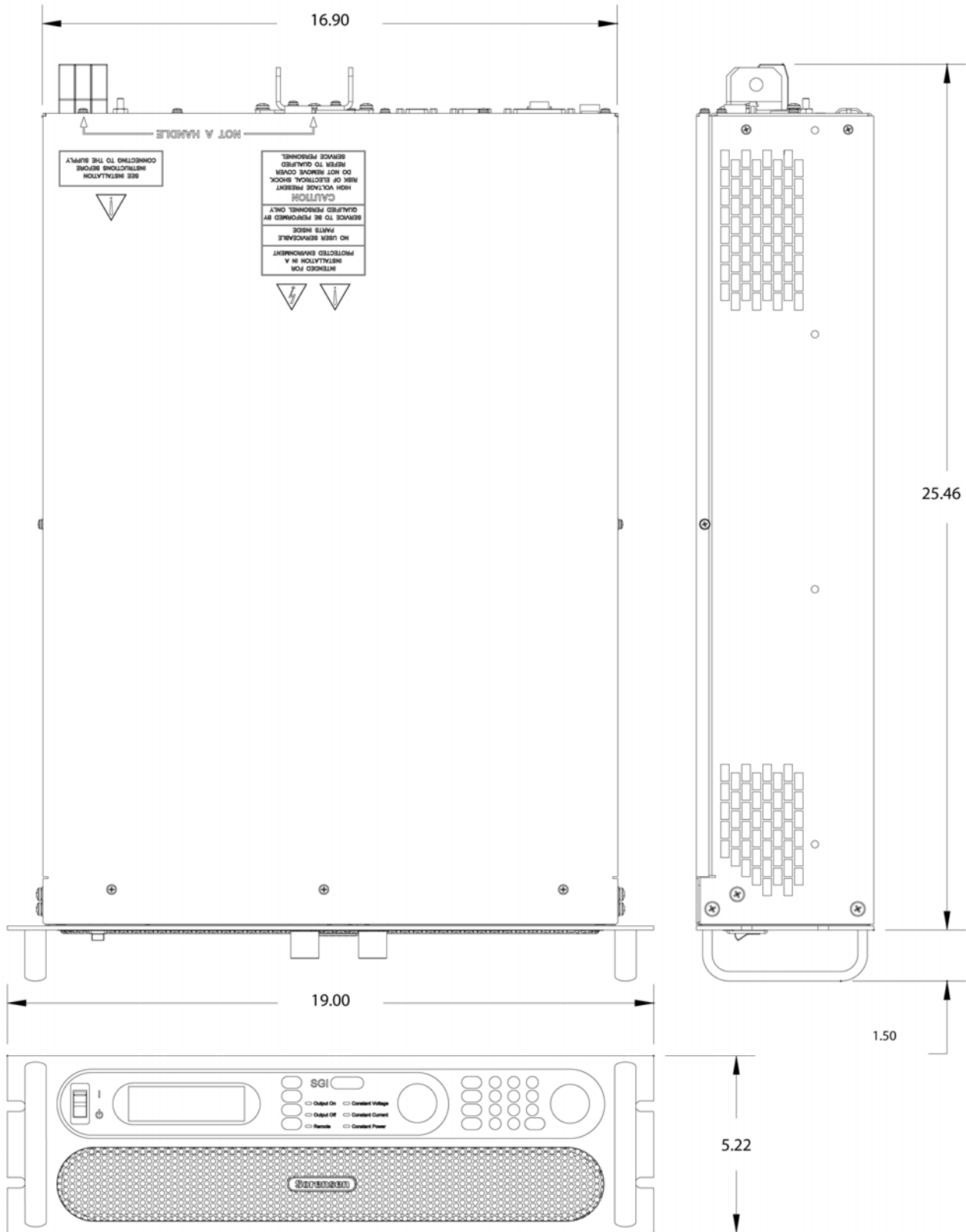

Figure 2-2. SGI Unit Dimensions, 3U Model

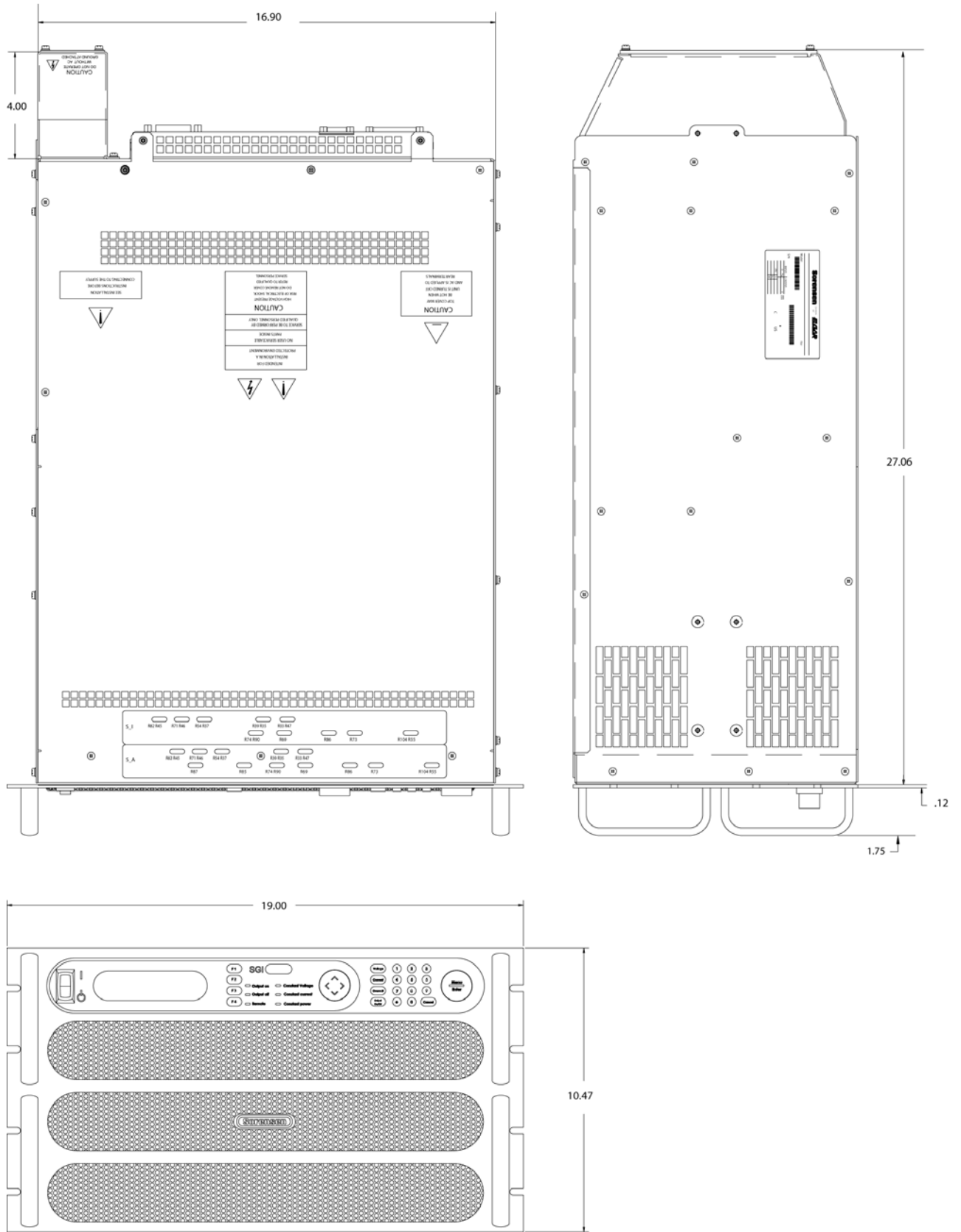

Figure 2-3. SGI Series Outline Drawing, 6U Models, 20kW to 30kW

2.8 Installation Drawings

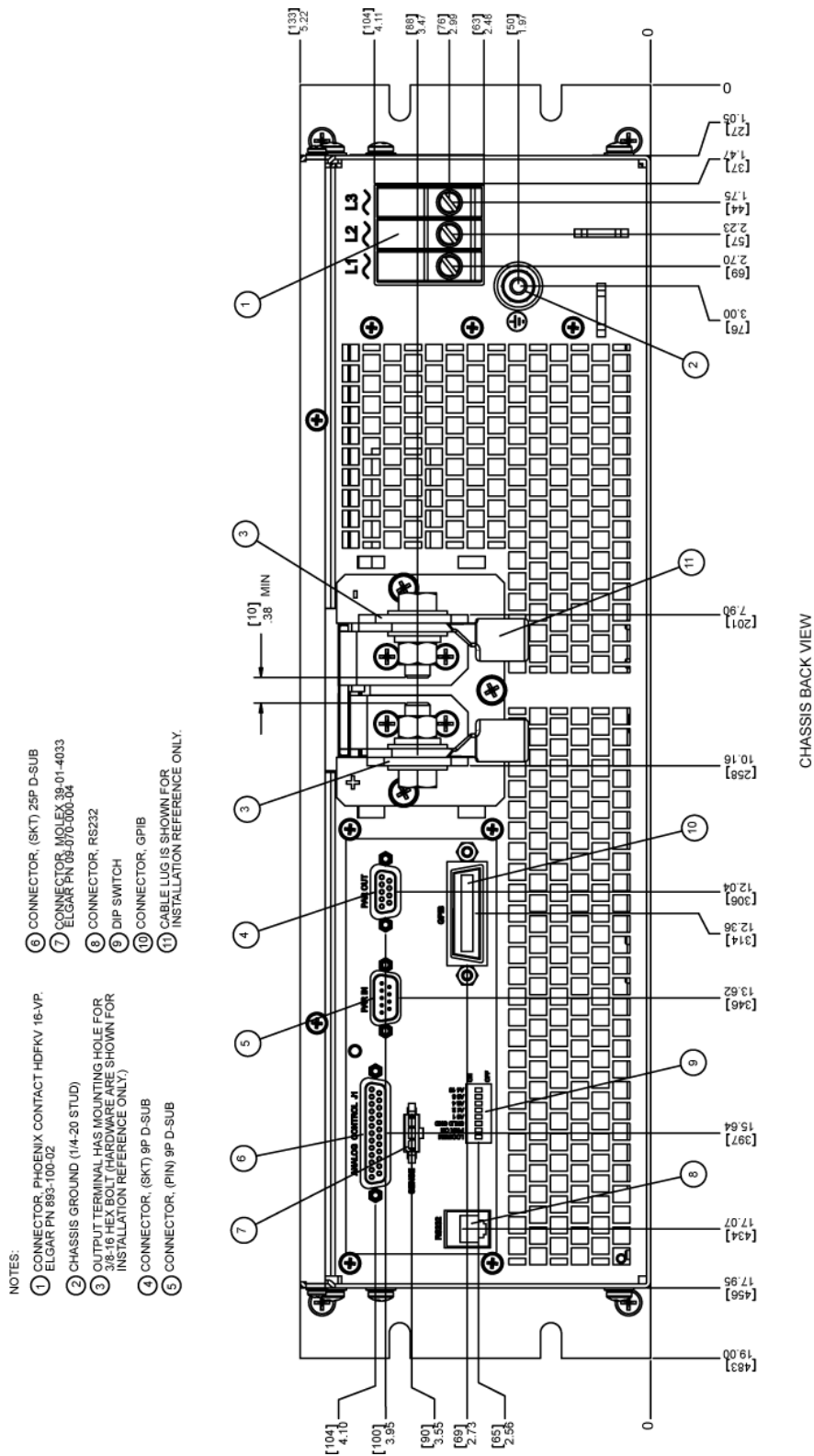

Figure 2-4. Rear Panel Input-Output Connector Locations

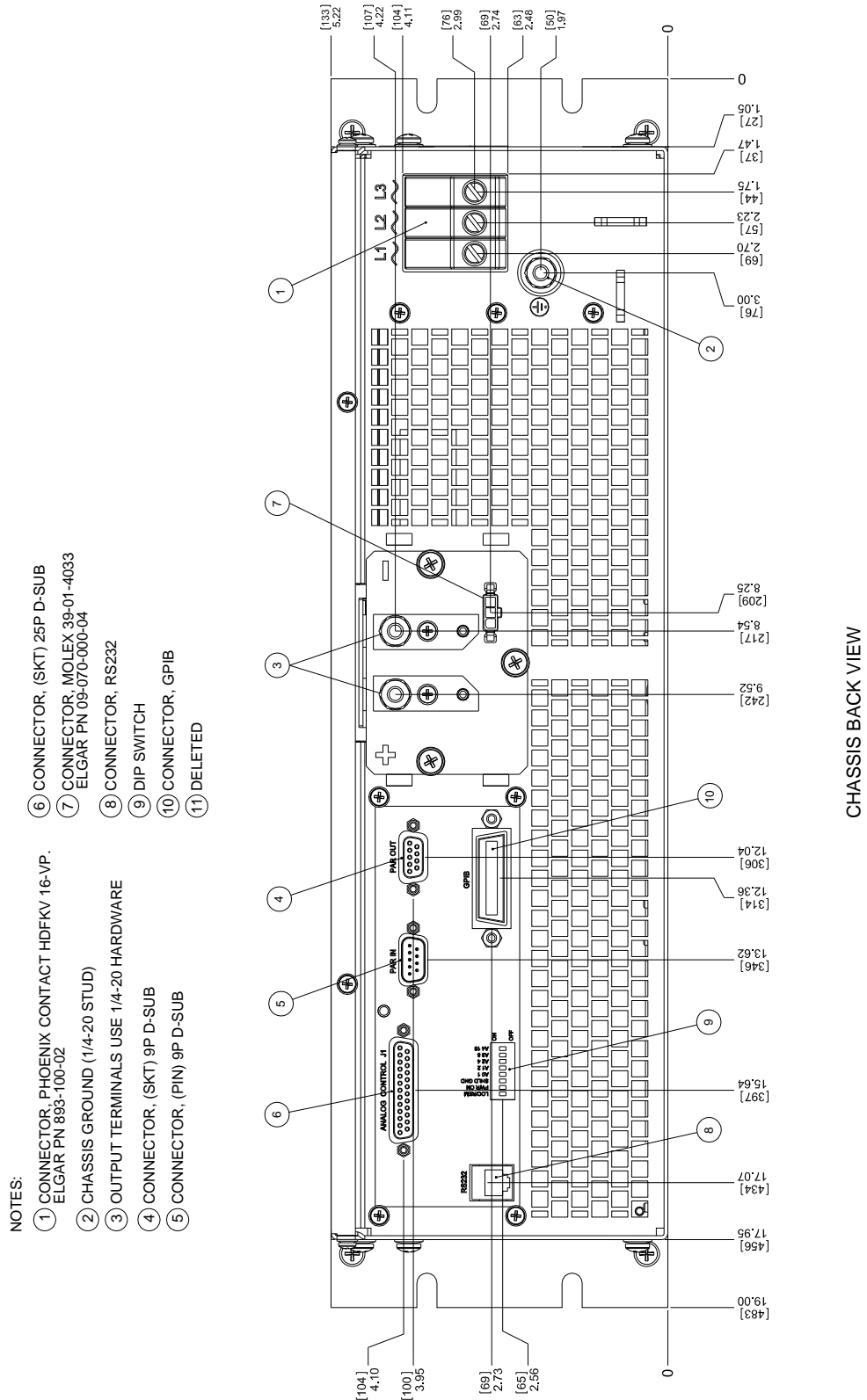

Figure 2-5. 800V Rear Panel Input-Output Connector Locations

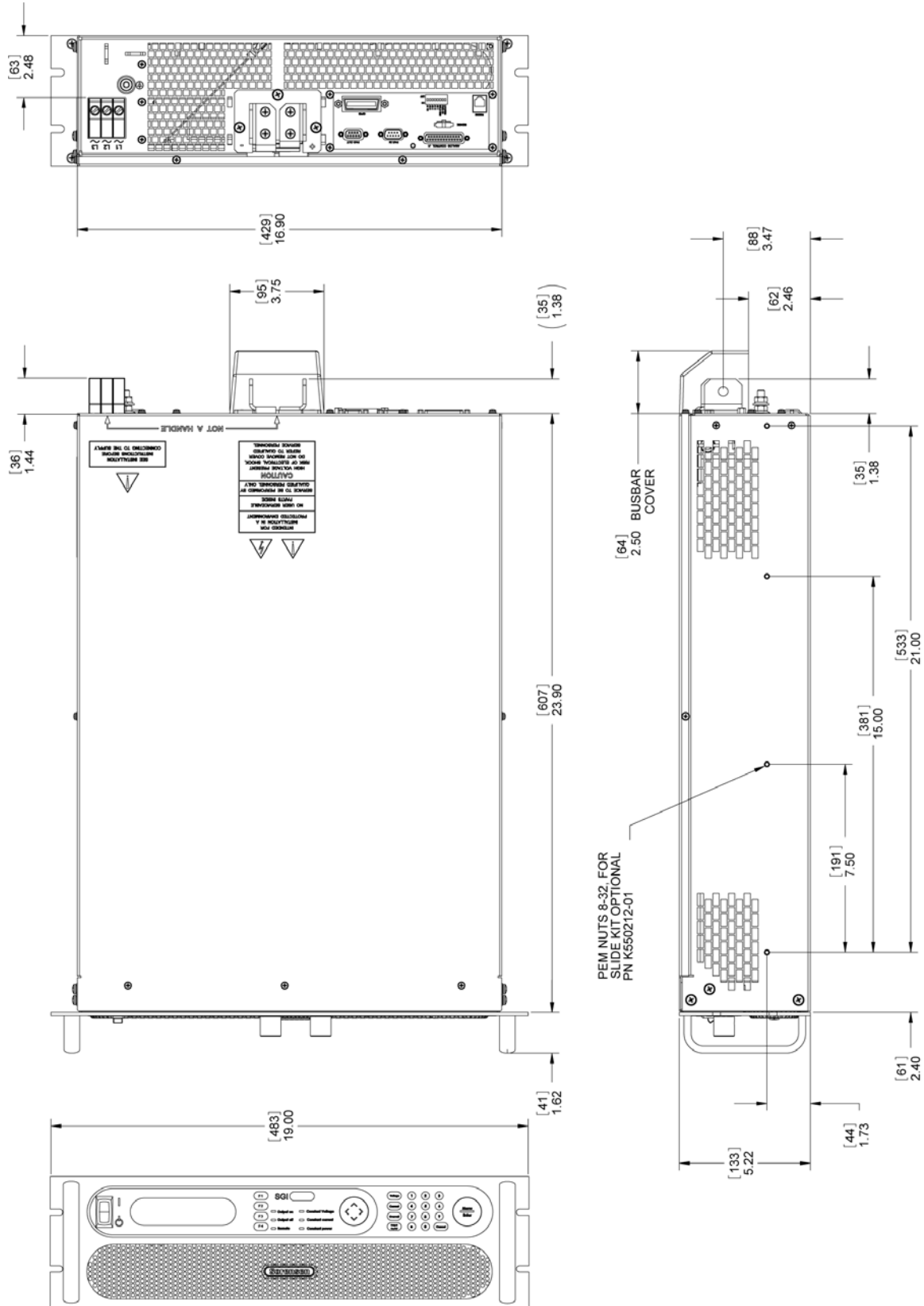

Figure 2-6. SGI Detailed Chassis Dimensions for Installation

This page intentionally left blank.

SECTION 3 OPERATION

3.1 Introduction

The SGI series adds powerful functionality and sequence programming to the SG family of DC power supplies. The graphical display, front panel keyboard and context sensitive keys, make setup of the sophisticated functions simple and easy. The following sections provide detailed information on the programming conventions and front panel menu structure of the SGI series.



WARNING!

The power-up factory default state is output enabled.

3.2 Controls and Indicators

3.2.1 Front Panel

Refer to Figure 3-1 and the corresponding descriptions below for an explanation of front panel controls and indicators on the SGI series power supply.

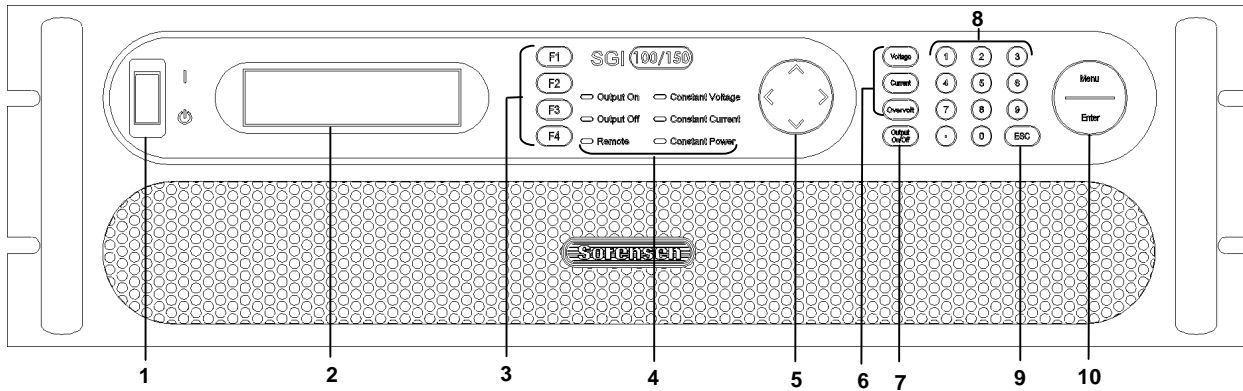



Figure 3-1. Front Panel Controls and Indicators

- 1 ON/OFF Switch** Turns on or off power to control unit.



WARNING

The OFF position of the power switch does not remove voltage from the input terminal blocks. Remove external power before servicing the unit.
- 2 Front Panel Display** 256 x 64 graphic VFD, displays menus, settings and functions.
- 3 Function Keys F1 - F4** Context-sensitive 'soft' keys execute command specified on front panel display by its corresponding label.
- 4 LED Mode Indicators:** Indicates presently active mode where lit.

 - Output On Power to output terminals is live
 - Output Off Power to output terminals is disabled
 - Remote Supply presently controlled by computer
 - Constant Voltage Power supply currently in Voltage mode
 - Constant Current Power supply currently in Current mode
 - Constant Power Power supply currently in Power mode
- 5 NAVPAD** Navigation Pad navigates between and within screens; also used for increment/decrement control to make live updates (see Navigation, Section 3.5, and Editing, Section 3.6).
- 6 Programming Keys:** Also called "hard code" keys

 - Voltage Jumps directly to Voltage programming
 - Current Jumps directly to Current programming
 - Overvolt Jumps directly to Overvoltage Protection programming
- 7 Output On/Off Key** Enables/disables power to the output terminals.
- 8 Numeric Keys 0-9** Used to enter specific values for editable items
- 9 ESC (escape) Key** Cancels numeric input and/or returns to previous menu.
- 10 Menu/Enter:**

 - Menu** returns to Home Menu Page 1 (see Menu Map, Section 3.7).
 - Enter** sets a value that was input via numeric keys.

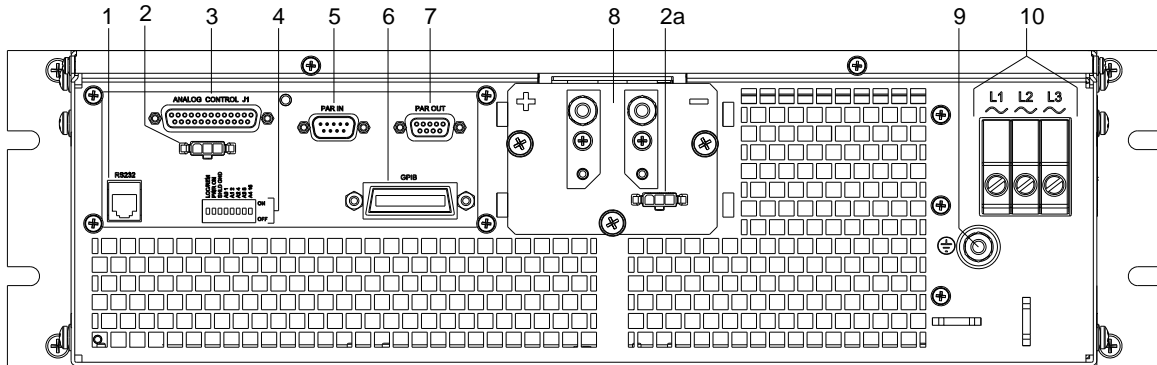

Figure 3-2. SG Rear Panel with GPIB Option

- | | | |
|-----------|-------------------------------|--|
| 1 | RS232 Connector | Connector for remote control |
| 2 | SENSE Connector | J3 Input connector for load voltage sensing to correct for line drops in the load cables (see Section 3.12). |
| 2a | HV SENSE Connector | J3 Input connector for load voltage sensing, 800V models only. |
| 3 | ANALOG CONTROL | J1 I/O connector for input programming and analog output monitoring signals as well as status indication and remote shutdown signals. See Table 3.1 for individual pin descriptions. |
| 4 | Configuration Switch | Four-position DIP switch to configure the unit with a GPIB option. |
| 5 | Parallel In Connector | Allows master/slave configuration of up to five units when connected to another unit's Parallel Out connector
See Section 3.16. |
| 6 | GPIB Connector | Connector for remote control. |
| 7 | Parallel Out Connector | Allows master/slave configuration of up to five units when connected to another unit's Parallel In connector.
See Section 3.16. |
| 8 | Output Bus Bars | Positive (+) and negative (-) outputs. |
| 9 | Ground | Connection for ground wire. |
| 10 | AC Input Connectors | Connection for 3-phase AC. |

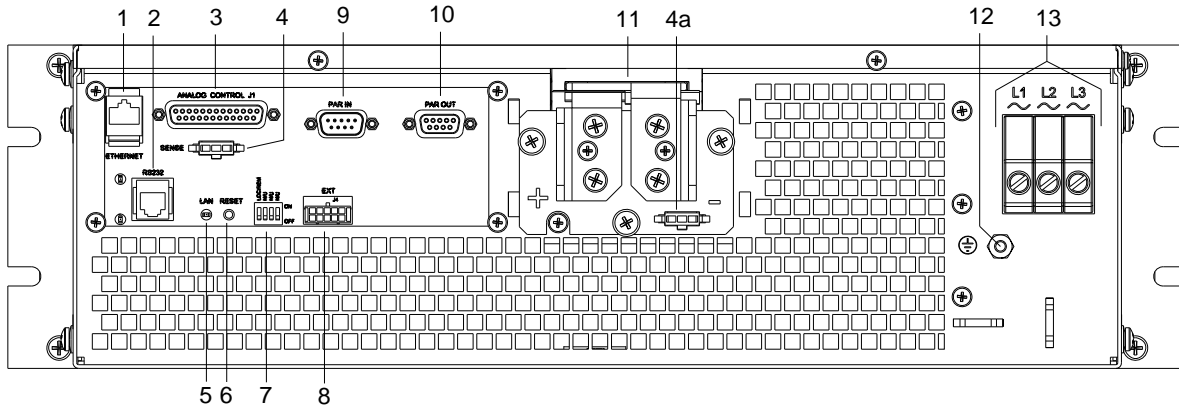
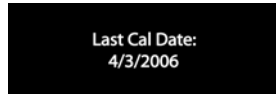

Figure 3-3. SG Rear Panel with Ethernet Option

- | | | |
|-----------|--------------------------------|--|
| 1 | ETHERNET Connector | Optional connector for remote control via Ethernet. |
| 2 | RS232 Connector | RJ-11 connector for remote control |
| 3 | ANALOG CONTROL | J1 I/O connector for input programming and analog output monitoring signals as well as status indication and remote shutdown signals. See Table 3.1 for individual pin descriptions. |
| 4 | SENSE Connector | J3 Input connector for load voltage sensing to correct for line drops in the load cables (see Section 3.12). |
| 4a | HV SENSE Connector | J3 Input connector for load voltage sensing, 800V models only. |
| 5 | LAN | LED steady-lit indicates Network connectivity; blinking indicates "Instrument ID" (See SG Series Programming Manual). |
| 6 | RESET Switch | Returns configuration parameters to factory default settings. |
| 7 | Configuration Switch | Four-position DIP switch to configure the unit with a GPIB option. |
| 8 | External User Connector | Provides external auxiliary control signals. |
| 9 | Parallel In Connector | Allows master/slave configuration of up to five units when connected to another unit's Parallel Out connector
See Section 3.16. |
| 10 | Parallel Out Connector | Allows master/slave configuration of up to five units when connected to another unit's Parallel In connector.
See Section 3.16. |
| 11 | Output Bus Bars | Positive (+) and negative (-) outputs. |
| 12 | Ground | Connection for ground wire. |
| 13 | AC Input Connectors | Connection for 3-phase AC. |

3.3 Initial Start-up and Displays

Upon initial start-up of unit, the following screens display in sequence after initial splash screens, which show manufacturer's information:



Last Cal Date

Displays for seven seconds, showing date that the unit was last calibrated. See *SG Series Programming Manual*, P/N M550129-03, for calibration information and how to update "Last Cal Date."

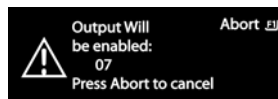

Output-Enabled Warning

Indicates number of seconds left in a 10-second countdown, warning the user that the output will be enabled at the end of the countdown unless the process is aborted by pressing the F1 key on the front panel. Once aborted, the output remains off until the user enables it with the Output On/Off key (see Controls and Indicators, Section 3-1).

This warning appears only if the unit is both in Local mode *and* was last set and saved to enable the output at its next start-up. See Section 3.8.2 for changing and saving the Power On (PwrOn) Output settings.

Note: Factory default setting for Output at first-time start-up is off, i.e., not enabled.



Home Menu, Page 1

Final screen to display upon initial start-up of the unit; it is from here that the user may access all menu functions. See Menu Map, Section 3.7, for Home Menu pages 1 through 3 and their submenus. See Functions, Section 3.8, for access and program menu functions.



Home Timeout

Displays after 30 seconds of idle time in any of the three Home Menu pages; pressing the F4 key on the front panel returns the display to Home Menu Page 1.

3.4 Display Elements

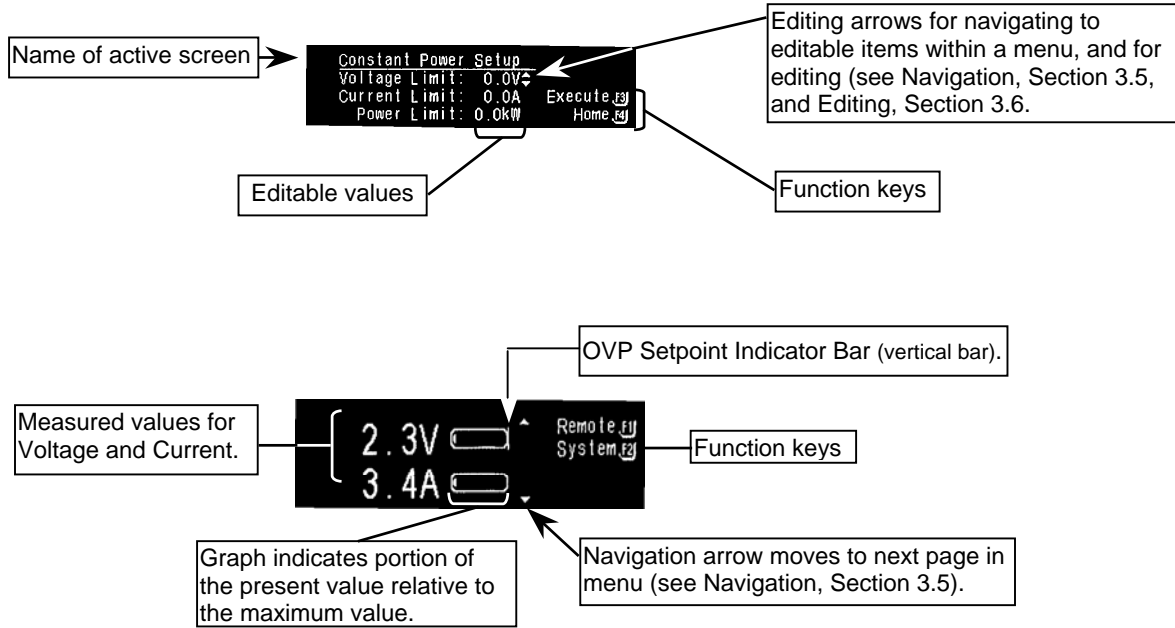

3.5 Navigation

The primary keys used to navigate are: the escape key (ESC), the function keys (F1-F4), the navigation pad (NavPad), the menu and enter key (Menu/Enter) and voltage, current, overvoltage protection programming keys (V/I/OVP Prog). Their functions are as follows:

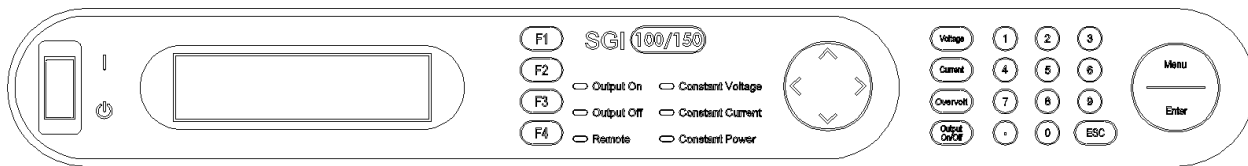

(ESC) – Probably the most important key to remember,  escape works like the back or return button in a browser, bringing the display back one menu level to the previous menu. Continued pressing will eventually return the display to the Home Menu. Escape is not functional in a Fault Screen.

(F1-F4) – To enter a function menu or execute a function, press the corresponding Function key to the right of the function to be entered or executed. Only those function keys defined within that menu will be operational.

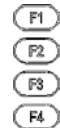

(NavPad) – Used to move between menu pages and between editable items within a menu



- If a Navigation Arrow is displayed at the top and/or bottom of a screen, \triangle ∇ pressing up/down on the NavPad allows the user to move between pages within a menu.
- If the Editing ∇ Arrow is displayed, pressing left/right on the NavPad allows the user to move between editable items within a menu. If a screen has only one editable item, left/right arrow has no effect. See Editing, Section 3.6.

(Menu/Enter) – Pressing “Menu” from any submenu jumps the display directly to the Home Menu, page 1, with one exception - see NOTE below. Pressing “Enter” moves the editing arrow to the next editable item in the menu, similar to the right arrow on the NavPad.



(V/I/OVP Prog) – Pressing the “Voltage,” “Current,” or “Overvolt” programming key displays the Default Programming menu with the editing arrow at the corresponding function in that menu - see NOTE below.

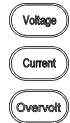

NOTE: The “Menu” key and the “Voltage,” “Current” and “Overvolt” programming keys do not function while running a sequence, paused in a sequence, in sequence single step mode or running in power mode.

3.6 Editing



WARNING!

While Output is enabled, the editable item being programmed (Voltage, Current, Over-Voltage or Power) is “Live Updated” and takes effect on the output terminals immediately.

The primary keys used to edit are: (ESC), (F1-F4), (NavPad), (Menu/Enter) and (Keypad 0-9). Their functions are as follows:

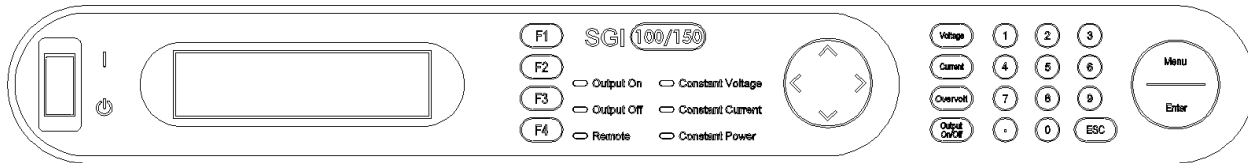

(ESC) – In editing, ESC (escape) functions like the escape key on a keyboard. While programming an editable item, the escape key can be used to clear the entered value before it is accepted and takes effect. This leaves the program function setting at the original value before editing began.

(F1-F4) – Not used to program editable items directly, Function keys may be used to save, recall, cut, past, insert or delete edits made in some menus. These functions will be indicated to the left of the function keys in the specific menus they are used.

(NavPad) – The NavPad functions as an increment/decrement editing and “Live Update” (Pressing Up/Down). “Live Update” means the value or item displayed due to an edit change from the NavPad, is actively changing the operation of the supply in real time when Output is On. This includes programming editable items as well as scrolling through option lists within a menu.

- Programming editable items: If an Editing Arrow  is displayed, pressing the NavPad up or down incrementally adjusts the editable item value adjacent to the Editing Arrow by the least significant digit per press in the respective direction. If the NavPad is pressed up or down and held, the selected editable item will accelerate from set point to full-scale or from set point to zero, respectively, within 15 seconds. If the output is enabled, the output terminals will “Live Update” with the programmed changes.
- Scrolling through option lists: Pressing the NavPad up or down incrementally scrolls through the listed items available and “Live Update” selects the item being displayed. Option lists wrap around from top to bottom (pressing NavPad down) and bottom to top (pressing NavPad up).

(Menu/Enter) – “Enter” is used to accept a value edited or entered using “Keypad 0-9.” When “Enter” is pressed the value edited is programmed into memory and the Editing Arrow moves to the next editable item. If the output is enabled, the programmed value takes effect on the output terminals immediately after “Enter” is pressed.

- “Menu” is not used to edit.

(Keypad 0-9) – Similar to the number pad on a phone, “Keypad 0-9” is used to program numeric values into editable items using single digit entry. “Enter” must be pressed to program the edited value into memory. The decimal key is for future use.

- If the editing arrow is displayed, pressing “Keypad 0-9” will activate the editable item to the left of the Editing Arrow and display the number(s) pressed. As the first number is input, the display begins with the least significant position first, and shifts left as additional numbers are pressed (see Example below). Once the user starts to input a value, the Editing Arrow will begin to blink – a blinking Edit Arrow indicates that the value entered has not been programmed into memory; also, both the NavPad right/left arrows and the NavPad up/down “Live Update” are no longer operational in this condition. The user must either abort (see 3.6.1 Aborting an Edit, below) or press Enter to accept the inputted value.

Example: Programming 50V

Navigate to voltage programming by pressing the “Voltage” programming key. The Default Programming menu is displayed and the Editing Arrow is to the right of the “Set Volt” editable item value. Begin entering the value:

- Press “5” The display “Set Volt” value reads, “0.5V” (Notice the Editing Arrow begins to blink).
- Press “0” The display “Set Volt” value reads, “5.0V”
- Press “0” The display “Set Volt” value reads, “50.0V”
- Press “Enter” The value is programmed into memory. (Notice the Editing Arrow stops blinking and moves automatically to the next editable item. This means the value has been programmed).

3.6.1 Aborting an Edit

“Escape” can be used to cancel an edit before it is accepted. When pressed, the value of the editable item displayed will default to the previous value before editing began. The Editing Arrow does not change position and will no longer be blinking.

Note: *If an invalid or out-of-range value is entered with either the NavPad or “Keypad 0-9”, it will be ignored and the user will be alerted through an audible signal.*

3.7 Menu Map

3.7.1 Home Menu

Home Menu is made up of three pages from which the user may navigate to the various function or command screens.

Return to Home Menu Page 1 from anywhere in system by pressing Escape as needed, **ESC** or Menu, except as noted in Section 3.5



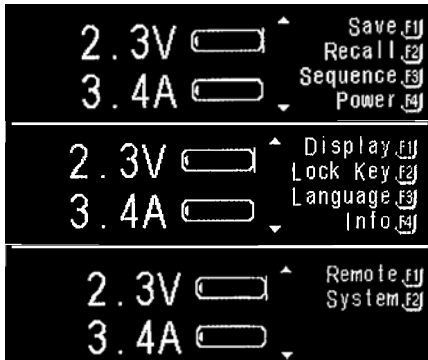

Page 1

Page 2

Page 3

Toggle between pages by pressing up or down on the NavPad. See Section 3.2, Controls and Indicators.



NavPad

3.7.2 Default Programming Menu

Access this menu directly with the hard-code keys, Voltage, Current, or Overvoltage, on the Control Panel. See Section 3.8.1 for details.

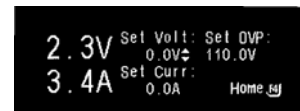

3.7.3 Navigating from Home Menu Page 1

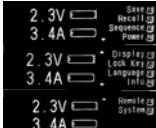

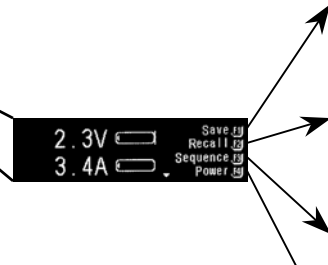

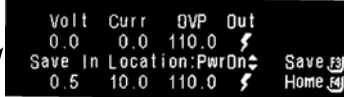

SAVE - See Section 3.8.2 for details.

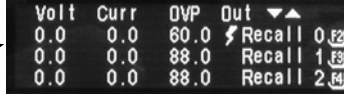

RECALL - See Section 3.8.2 for details.

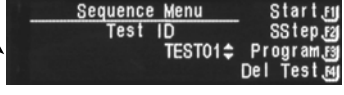

SEQUENCE See Sections 3.7.6 for submenus and 3.8.4 for details.

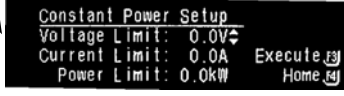

POWER - See Sections 3.7.8 for next screens and 3.8.5 for details.

3.7.4 Navigating from Home Menu Page 2

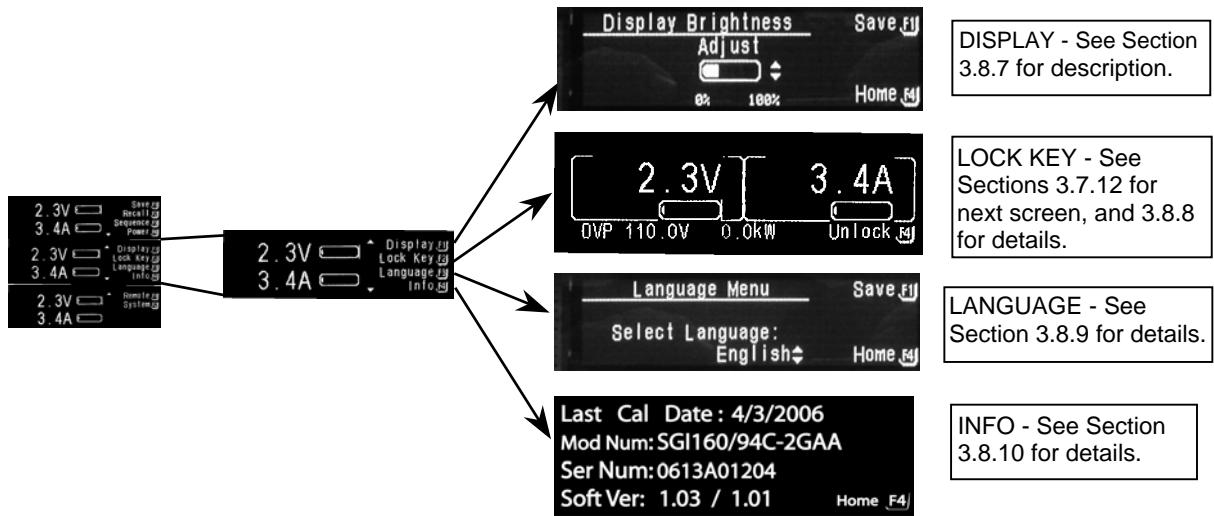

3.7.5 Navigating from Home Menu Page 3

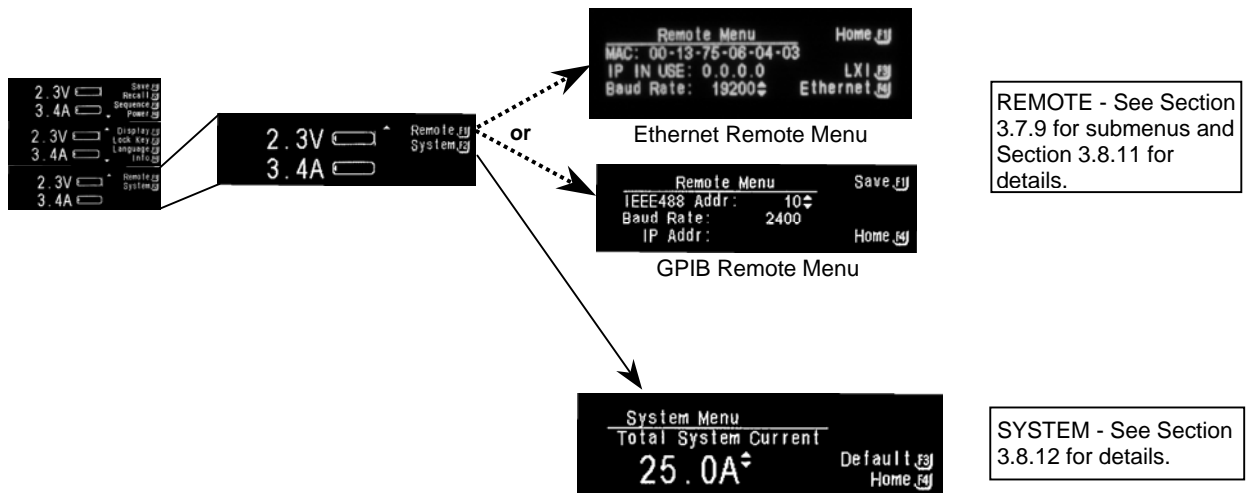

3.7.6 Sequence Menu

Refer to Basic Sequence Operation under Section 3.8.4.

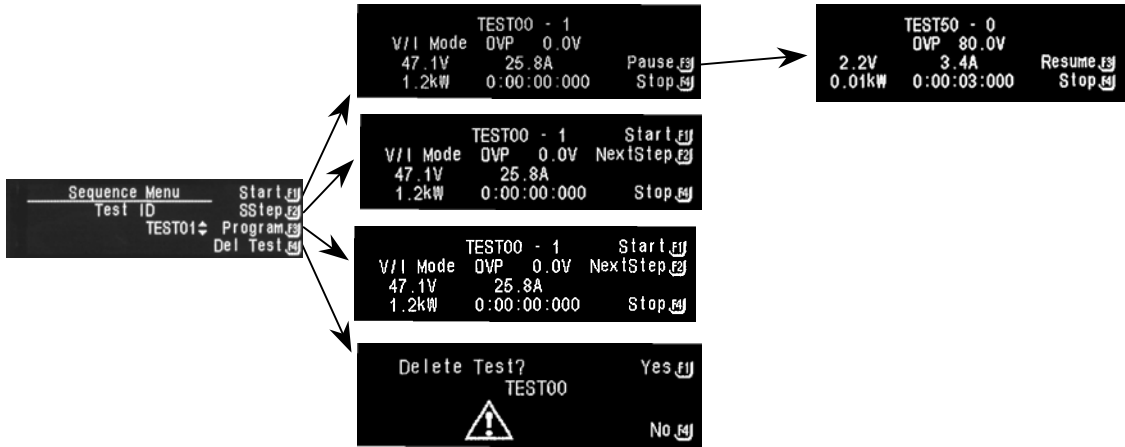

3.7.7 Sequence Programming Operation

The screens in this section show the various operations available for programming a sequence. See details on Step Operations under Section 3.8.4.

<pre>TEST00 - 1 CopyStep NDP PasteStep Insert Delete</pre>	<pre>TEST00 - 1 CopyStep Repeat PasteStep Insert Delete</pre>	<pre>TEST00 - 1 CopyStep Next PasteStep Insert Delete</pre>
<pre>TEST00 - 1 CopyStep V/I Mode PasteStep 0.0V 0.0A Insert 0:00:00:000 Delete</pre>	<pre>TEST00 - 1 CopyStep Subcall PasteStep TEST00 Insert Delete</pre>	<pre>TEST00 - 1 CopyStep Stop PasteStep Insert Delete</pre>
<pre>TEST00 - 1 CopyStep Ramp V PasteStep Vi= 0.0V Vf= 0.0V Insert 0.0A 0:00:00:000 Delete</pre>	<pre>TEST00 - 1 CopyStep Return PasteStep Insert Delete</pre>	<pre>TEST00 - 1 CopyStep Goto PasteStep TEST00 Insert Delete</pre>
<pre>TEST00 - 1 CopyStep CP Mode PasteStep Limits: 0.0V 0.0A Insert OW 0:00:00:000 Delete</pre>	<pre>TEST00 - 1 CopyStep Loop PasteStep Count: 5 Insert Delete</pre>	<pre>TEST00 - 1 CopyStep Pause PasteStep Insert Delete</pre>

3.7.8 Constant Power Setup Menu

See Section 3.8.5 for details.

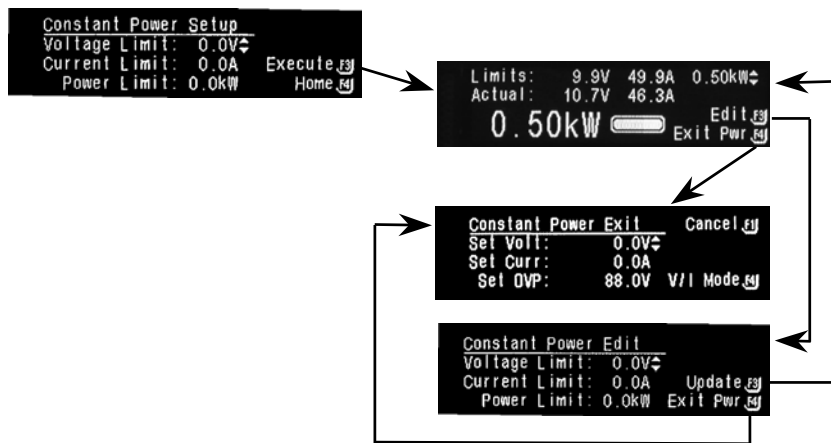

3.7.9 Remote Menu

Remote menu is either GPIB or Ethernet option. The submenus for Ethernet are mapped here; there are no submenus for the GPIB Remote screen (see Section 3.8.11 for details).

ETHERNET

The Ethernet Remote Menu provides submenus for LXI Settings (F3) and Ethernet Menu (F4). The Ethernet Menu provides submenus for Server Port (F3) and Static IP Configuration (F4). See Section 3.8.11 for details.

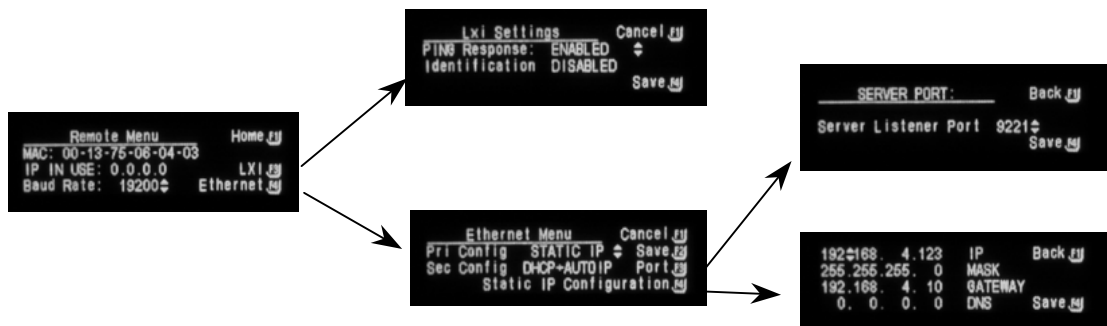

3.7.10 Remote Control Screen Examples

Remote screens display when operation is controlled by computer. Pressing F4 from any Remote screen returns operation to Local Mode.



3.7.11 Warning Screens

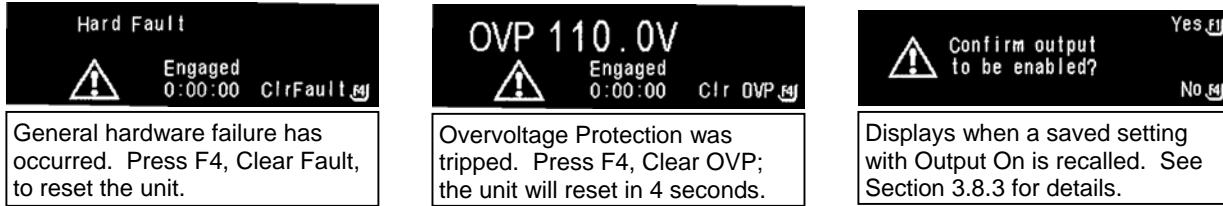

3.7.12 Other Screens

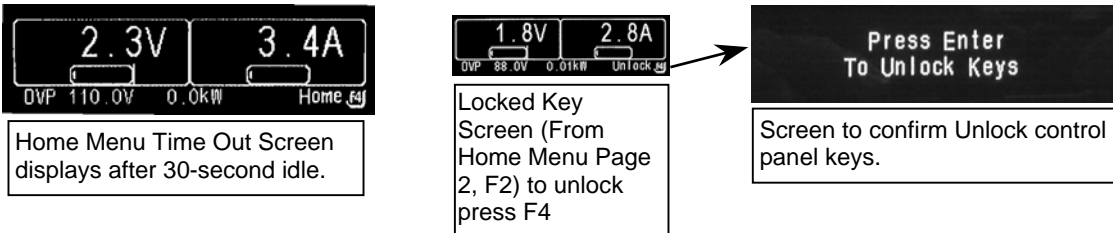

3.8 Functions

This section describes various programming/operating instructions.

3.8.1 Voltage, Current, and Overvoltage Protection Programming

Press Voltage, Current, or Overvoltage key on Control Panel to go directly to the Default Programming Menu. The editing arrow will be displayed next to the corresponding item pressed.

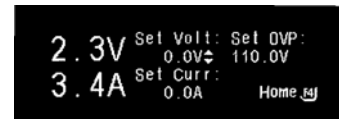

PROGRAMMING VOLTAGE

Go directly to Voltage programming by pressing the  key. The Default Programming menu is displayed and the Editing Arrow is to the right of the "Set Volt" editable value. Edit the value by NavPad up/down or by entering the value with "Keypad 0-9". For more details see Section 3.6, Editing.

PROGRAMMING CURRENT

Go directly to Current programming by pressing the  key. The Default Programming menu is displayed and the Editing Arrow is to the right of the "Set Curr" editable value. Edit the value by NavPad up/down or by entering the value with "Keypad 0-9". For more details see Section 3.6, Editing.

PROGRAMMING OVERVOLTAGE

Go directly to Overvoltage trip point programming by pressing the  key. The Default Programming menu is displayed and the Editing Arrow is to the right of the "Set OVP" editable value. Edit the value by NavPad up/down or entering the value with "Keypad 0-9". For more details see Section 3.6, Editing.

3.8.2 Save

There are 10 memory locations (PwrOn and 1 through 9) into which a programmed output configuration of Voltage, Current, OVP (Overvoltage Protection trip point) and Output Condition can be stored. From Home Menu Page 1 press (F1) to enter the Save menu. Voltage, Current and OVP values programmed in the Default Programming menu will be pulled into the Save menu, top line, upon reaching that menu. In addition, the present output condition, output engaged or output disabled, will be indicated.

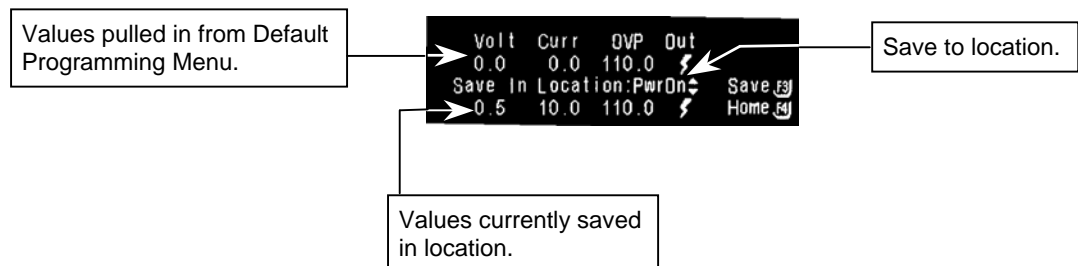

EDIT VOLTAGE, CURRENT AND OVP:

Toggle between the editable items using the NavPad and edit Voltage, Current and OVP to appropriate values (see Section 3.6 for editing details).

EDIT OUTPUT CONDITION:

Pressing NavPad up/down will toggle the output condition indicator **on** () to indicate the output will be enabled and **off** (*blank*) to indicate the output will be disabled.

Note: Edits will not take effect until the configuration is saved.

SAVING A CONFIGURATION:

With the Editing Arrow adjacent to “Save Location” pressing NavPad up/down allows the user to scroll through the list of memory locations (PWR ON and 1-9). Select the appropriate location and press (F3) to save the configuration to that location. The bottom line of the screen will update with the configuration information saved. Press (F4), “Escape” or “Menu” key to exit to the Home Menu Page 1 at any time.

SAVING TO PWR ON:

“PWR ON” is a unique “Save Location.” If a configuration is saved to “PWR ON” location, the next time the ON/OFF front panel switch is cycled, the SGI unit will power up into the state this configuration was saved. If the Output Condition was saved as **on** (⚡), which means power enabled, a warning screen will be displayed at power up. The user will have 10 seconds to press (F1) and abort the operation. If the count times out, the supply output terminals will be live and programmed to the saved configuration values. See Section 3.3 for Output-Enabled Warning! All other saved configuration locations must be recalled to become active. See Section 3.8.3 Recall.

3.8.3 Recall

There are 10 memory locations (as above, PwrOn and 1-9) from which a programmed output configuration of Voltage, Current, OVP (Overvoltage Protection trip point) and Output Condition can be recalled.



From Home Menu Page 1 press (F2) to enter the Recall menu. Using the NavPad up/down arrows scroll through the list of saved configurations. Recall a saved configuration by pressing the function key (F2-F4) to the right of that configuration. If a configuration was saved with the Output Condition **on** (⚡) and that configuration is recalled, a warning screen (Menu Map Section 3.7.9) will be displayed*. The user is given the option to press Yes (F1) to enable or No (F4) to disable the output. All other settings will be programmed according to the recalled configuration regardless of this choice.

* **Note:** The warning screen will not appear if the Output is already enabled.

3.8.4 Sequencing

INTRODUCTION

The SGI sequencing function allows the user to set up the supply to automatically run a series of voltage, current and power mode operations. This is especially useful for setting up the supply to test to compliance standards, or unburdening the test computer in automated testing applications. Via RS232, IEEE-488 or Ethernet, an external computer can trigger the sequences (see SG Series Programming Manual). Up to 50 sequences may be stored, with each sequence containing up to 20 individual steps. With the ability to string sequences together and an extensive list of step functions such as ramping, looping, gotos and subroutine calls, the user can define a nearly infinite variety of test sequences.

The following sections will assist the user in programming, testing and running a sequence from the front panel.

BASIC SEQUENCE OPERATION

To access the main Sequencing menu press F3 from Home Menu Page 1. From here any one of 50 sequences may be selected. The default names for sequences are TESTxx where xx is a number from 01 to 50. Using SCPI commands via the RS232 or IEEE-488 interface, the user may rename these test sequences with meaningful names of up to 15 characters (see SG Series Programming Manual).

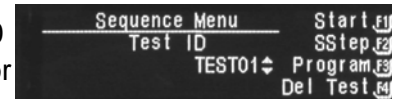

Note: DO NOT use non-sequence-related SCPI commands while performing sequence operations.

Note: DO NOT use sequence SCPI commands as stand-alone commands outside a sequence.



CAUTION - RESTRICTIONS ON SEQUENCE PROGRAMMING

In order to allow maximum flexibility for generating small incremental changes during a test sequence, the SGI allows 1ms time resolution on each step. With this capability, however, it is possible to create output changes that generate large, and potentially damaging, currents in the output capacitors of the unit.

When creating test sequences, please use the following guidelines to prevent damage to the unit (see Note):

- Estimate the AC frequency and peak-to-peak voltage (V_{p-p}) of the desired test sequence.
- Convert the estimated V_{p-p} to a % of maximum output voltage (e.g., if V_{p-p} is 10V and maximum voltage of the supply is 100V, then % V_{p-p} – 10%)

- *Verify that the frequency and %Vp-p does not exceed the values below:*

Frequency	% Vp-p
10Hz	25%
50Hz	5.0%
100Hz	2.5%
150Hz	1.67%
200Hz	1.25%

Another consideration is the actual rise and fall capabilities of the output of the supply. Although damage will not occur, the shape of the output waveform will be affected by these differences. These vary widely depending on the load conditions, contact the factory for further information.

Note: *Contact the factory for detailed information if the desired waveform exceeds the recommended limits as discussed.*

To change the test sequence, use the NavPad up/down to scroll through the test list. From this menu the user may Start (F1), Single Step (F2), Program (F3) or Delete (F4) a sequence.

START, press F1 from the main Sequence Menu to start and run a test sequence. The display will show the test sequence name and step number (e.g., TEST01-12, Sequence TEST01, step 12). It will also indicate the current operation being executed (see Section 3.8.4.3 Operations) and will display voltage, current, OVP, power and time remaining for that step. The time format is hhhh:mm:ss:sss (last three digits are milliseconds).

User may pause or stop the test at any time by pressing either F3 to pause or F4 to stop the sequence. The output will pause or stop in the same state as the test step was when the key was pressed. Pressing F3 (Resume) restarts the sequence from the beginning of the same step. (Note: For steps with voltage or current ramps, the step will resume at the beginning of the ramp and not at the point at which the ramp was paused.) Pressing F4 (Stop) to stop the sequence returns the display to the main Sequence Menu.

SINGLE STEP, press F2 from the main Sequence Menu to single step through a test sequence. The display will show the test sequence name and step number. It will also indicate the current operation being executed and display voltage, current, OVP, power and time remaining for that step.

User may start the sequence after any step causing it to run in continuous mode, by pressing F1 (Start). Note that the sequence will start from the beginning of the test sequence, not the beginning of the current step. To continue to single step through each sequence step, press F2 (NextStep).

Pressing F2 NextStep before the timer ends, will replay the step. Pressing F4 (Stop) allows the user to stop the single step mode, and the display returns to the main Sequence Menu.

PROGRAM, press F3 from the main Sequence Menu to program a test sequence. The Test Sequence submenu shows the name of the current test sequence and step number. In addition it displays the primary operation of the test step (there are 13 different operations, see Section 3.8.4.3 Operations below). From this submenu the user may copy (F1), paste (F2), insert (F3) or delete (F4) a test step.

CopyStep (F1) – copies the current step characteristics into a buffer for later recall using the PasteStp (F2) function.

PasteStp (F2) – pastes the current characteristics from the copy buffer into the existing test step.

Insert (F3) – inserts a new step before the currently displayed test step. The default operation in the new step is set to NOP.

Delete (F4) – deletes the current test step from the test sequence, and inserts NOP into step 20 of the sequence.

DEL TEST, press F4 from the main Sequence Menu to delete the entire currently selected test sequence. If Del Test is selected, a warning screen will appear prompting the user to either confirm (Yes – F1) or cancel (No – F4) the delete action. Note that deleting a test actually fills each test step in the sequence with a NOP (see Section 3.8.4.3), and fills Step 21 with STOP operation.



STEP OPERATIONS

When programming a test sequence (see Section 3.8.4.2 above) each step operation can be any one of thirteen different functions. To access those functions, from Home Menu Page 1 press F3 (see Menu Map Sections 3.7.2, 3.7.5, and 3.7.6), and use the NavPad to scroll through the various step operations (see Section 3.5 for Navigation) while in the Sequence Step Programming submenu.

1. Once an operation has been selected for the present step, navigate to the editable items and input values for each setting as appropriate (see Section 3.6 Editing).
2. After programming a step, navigate to the step-number location on the screen and scroll to the next step number to be programmed.
3. Once at the next step number to be programmed, start again by choosing an operation for that step and continue as described above.

- At the end of the sequence or to abort the sequence, press either the Escape key or Menu to jump to the Save screen. F1 (Yes) saves the sequence (in non-volatile memory) and returns to main Sequence Menu. F4 (No) will *retain the current changes only until the power supply is turned off*. The next power on restores the sequence to its previous condition.

The following are descriptions for each sequence operation:

NOP - No Operation. Used as a placeholder in the test sequence, no values are changed during this step, and it does not add time to the sequence.

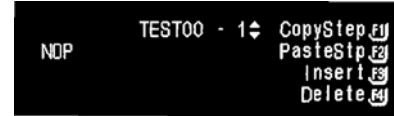

V/I Mode - Voltage/Current Mode. This operation sets the voltage, current and OVP to the programmed values for the set period of time during the sequence step. Navigate to each editable item to input values for Voltage, Current, Overvoltage Protection and duration.



Ramp V - Ramp Voltage. This operation allows the user to ramp the output voltage from an initial, or start, value (Vi) to a final, or stop, value (Vf) over the time period specified. Internally the unit uses Vi, Vf and the time to calculate an appropriate ramp function to drive the output during the test step. Use the NavPad to set the OVP, initial Voltage (Vi), final Voltage (Vf), Current limit, and duration.

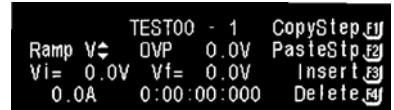

Ramp I - Ramp Current. This operation allows the user to ramp the output current from an initial, or start, value (Ii) to a final, or stop, value (If) over the time period specified. Use the NavPad to set the OVP, initial Current (Ii), final Current (If), Voltage limit, and duration.

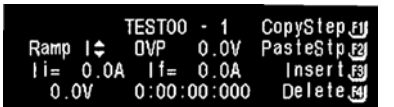

CP Mode - Constant Power Mode. This operation is similar to the V/I mode, except it sets the supply in a constant power mode (See section 3.8.5). Use the NavPad to input values for OVP, Voltage limit, Current limit, Constant Power setting and duration.

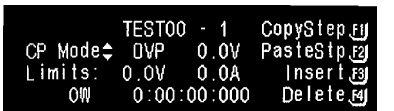

Repeat. This operation returns to the beginning of the test cycle (this could be a prior test sequence or the beginning of the current test sequence, depending on the number of branches and subcalls used in the affected sequences) and repeats all previously executed steps a single time. Once executed, the sequence continues to execute all remaining steps after the Repeat command. To repeat the preceding steps more than once, use the Loop operation.



Subcall. This operation calls another test that runs as a sub-sequence. If that sub-sequence includes a Return command, execution of the primary sequence resumes at the step following the Subcall step. Use the NavPad to scroll to the desired Test name and change as appropriate.



Return. This operation causes execution to resume at the step immediately following the most recent Subcall. When occurring in a primary sequence, without a prior Subcall, Return stops execution of the test sequence. Return is one of only three operations that may be used in step 21 of a test sequence.

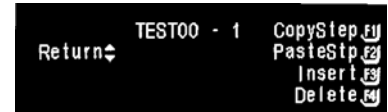

Loop. This operation causes the unit to repeat all steps between the Loop operation and the Next operation for the specified number of counts (maximum of 65,535). Use the NavPad to set the Count for the total number of loops.



Use the Next operation after the last step to be repeated.

Once the Loop has completed the set number of counts, the unit will continue to execute the remainder of the sequence.

Next. Next is used at the end of a Loop to signify the end of the looped sequence.



If Next is not preceded by the Loop operation, *this is an INVALID condition*. If the program encounters the Next command under these conditions, the sequence will abort and the output power to the terminals will be disabled.

Stop. Stops the test sequence execution and retains the last programmed output value. The Stop operation may be used in step 21 of a sequence.



Goto. This operation allows the sequence to exit the existing test sequence and begin another test sequence. Goto is used to string together multiple sequences for a single test. The Goto operation may be used in step 21 of a sequence.

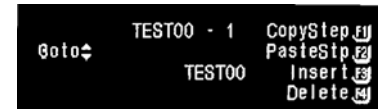

Pause. This operation suspends execution of the sequence and waits for operator input to press either the Resume key to continue the sequence or the Stop key to end the sequence.



SEQUENCING EXAMPLE

The following provides an example of programming and running a test sequence.

A typical burn-in sequence requires the voltage to the device-under-test (DUT) to ramp up to a nominal voltage, allow the unit to soak at that voltage for a period of time, then 'bump' up that voltage to another level, soak, etc., then return the output back to zero. In some cases, an on/off power cycle sequence may also be required. Figure 3.3 below provides a graphical representation of this example burn-in sequence.

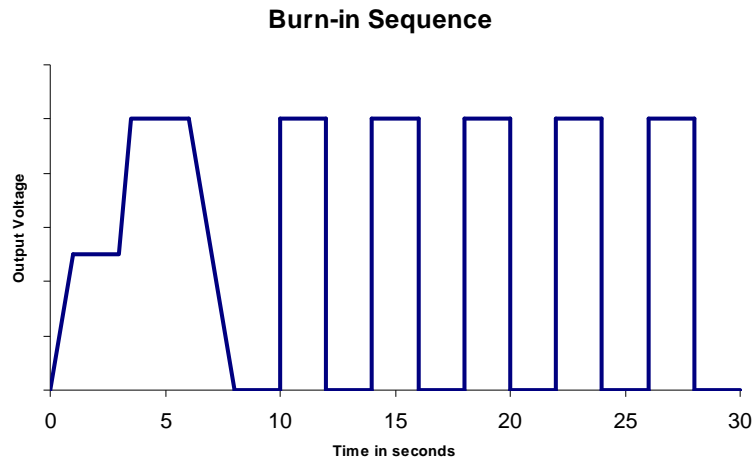

Figure 3-4. Burn-in Sequence Example

To begin programming a sequence it is important to know the exact settings for each step of the sequence. In this case, two sequences will be programmed: the first being the up/down ramp sequence, and the second the on/off sequence. The two will be strung together using a Goto command.

The example sequence will perform the following:

Sequence 1 – Up/Down Ramp

- Step 1 – Ramp the output voltage from 0V to 20V over a 1 second period
- Step 2 – Hold the voltage at 20V for 2 seconds
- Step 3 – Ramp the voltage from 20V to 40V over a 500ms period
- Step 4 – Hold the voltage at 40V for 2.5 seconds
- Step 5 – Ramp the voltage from 40V to 0V over a 2 second period
- Step 6 – Hold the voltage at 0V for 2 seconds
- Step 7 – Go to sequence 2

Sequence 2 – On/Off Loop

- Step 1 – Begin a loop and set the count to 5
- Step 2 – Turn on the voltage to 40V for 2 seconds
- Step 3 – Turn off the voltage for 2 seconds
- Step 4 – Execute the Next loop until all 5 are complete
- Step 5 – Stop the sequence

Run the sequence.

To program these sequences, do the following:

Sequence 1 – Up/Down Ramp

From the Home Menu Page 1, select F3 to enter the main Sequence Menu. Use the NavPad up/down to select the sequence (Test ID) labeled TEST01. Press F4 (Del Test) to reset all steps in TEST01 to a NOP condition. This establishes a known state for this sequence. Press F3 to enter the Sequence Step menu.

Step 1 – Ramp the output voltage from 0V to 20V over a 1 second period

From the Sequence Step menu, use the NavPad to set the test step to the first step, TEST01-1. Use the NavPad to set the operation to Ramp V mode. Set OVP to an appropriately high level (60V for this example), Vi to 0V, Vf to 20V and current to a nominal 10A (for this example we assume there is no load – or a very light load – connected to the output). Set the time duration to 1 second or (0:00:01:000). Once these values are set, press the F1 key to copy this setup into the copy buffer for later use.

Step 2 – Hold the voltage at 20V for 2 seconds

Use the NavPad to change to the next step (TEST01-2). Select the V/I Mode operation and set the OVP to 60V, voltage to 20V, current to 10A and time duration to 2 seconds.

Step 3 – Ramp the voltage from 20V to 40V over a 500ms period

Use the NavPad to change to the next step (TEST01-3). Use the F2 key to paste in a copy of the previously saved Ramp V step. Make changes to this step by changing Vi to 20V, Vf to 40V and the time duration to 500ms (0:00:00:500)

Step 4 – Hold the voltage at 40V for 2.5 seconds

Use the NavPad to change to the next step (TEST01-4). Select the V/I Mode operation and set the OVP to 60V, voltage to 40V, current to 10A and time duration to 2.5 seconds.

Step 5 – Ramp the voltage from 40V to 0V over a 2 second period

Use the NavPad to change to the next step (TEST01-5). Use the F2 key to paste in a copy of the previously saved Ramp V step. Make changes to this step by changing Vi to 40V, Vf to 0V and the time duration to 2 seconds.

Step 6 – Hold the voltage at 0V for 2 seconds

Use the NavPad to change to the next step (TEST01-6). Select the V/I Mode operation and set the OVP to 60V, voltage to 0V, current to 10A and time duration to 2 seconds.

Step 7 – Go to sequence 2

Use the NavPad to change to the next step (TEST01-7). Select the Goto operation and set the next step to TEST02. Press the ESC or Menu key to move to the Save Sequence screen and press F1 for Yes.

Sequence 2 – On/Off Loop

From the Home Menu Page 1, select F3 to enter the main Sequence Menu. Use the Navigation arrows to select the sequence labeled TEST02. Press F4 (Del Test) to reset all steps in TEST02 to a NOP condition. Press F3 to enter the Sequence Step menu.

Step 1 – Begin a loop and set the count to 5

Use the NavPad to change to the first step (TEST02-1). Select the Loop operation and set the count to 5.

Step 2 – Turn on the voltage to 40V for 2 seconds

Use the NavPad to change to the next step (TEST02-2). Select the V/I Mode operation and set the OVP to 60V, voltage to 40V, current to 10A and time duration to 2 seconds. Press F1 to copy this step to the copy buffer.

Step 3 – Turn off the voltage for 2 seconds

Use the NavPad to change to the next step (TEST02-3). Press the F2 key to paste the previously saved step into this step. Set the voltage to 0V, all other settings remain the same.

Step 4 – Execute the Next loop until all 5 are complete

Use the NavPad to change to the next step (TEST02-4). Select the Next operation.

Step 5 – Stop the sequence

Use the NavPad to change to the next step (TEST02-5). Select the Stop operation. Press the ESC or Menu key to move to the Save Sequence screen and press F1 for Yes.

This completes programming of the sequences.

To run this sequence, from Home Menu Page 1, press F3 to enter the main Sequence menu. Select TEST01 test sequence and press F1 to start the sequence. The display will show progress of the sequence and should complete in approximately 30 seconds.

3.8.5 Power Mode

The Constant Power Mode allows the supply to regulate the output to a constant power setting as opposed to the more common constant voltage or constant current modes of operation (see Section 3–9). (**Note:** This mode is intended primarily for loads with response times greater than approximately 10ms). While in this mode, the supply will continually adjust the voltage and current levels to attempt to maintain a constant power to the load. In order to provide additional protection for the load, voltage, and current limits may be set while in the Constant Power mode. If the unit cannot regulate to the Constant Power setting due to load conditions, it will regulate either at the voltage or current limit depending on the load demand. See Figure 3-5.

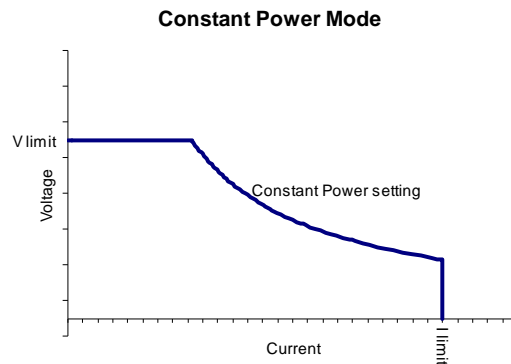

Figure 3-5. Constant Power Example

To access the Constant Power Setup menu, press the F4 key from Home Menu Page 1. Navigate to each editable item and enter the appropriate values. Press F3 to execute (the display jumps to Constant Power screen) or F4 to abort (the display returns to Home Menu Page 1).

```
Constant Power Setup
Voltage Limit: 0.0V↕
Current Limit: 0.0A Execute ⏎
Power Limit: 0.0kW Home ⏎
```

```
Limits: 9.9V 49.9A 0.50kW↕
Actual: 10.7V 46.3A
0.50kW  Edit ⏎
Exit Pwr ⏎
```

From Constant Power screen, the user may either edit the limits again or exit Power mode. F3 jumps to Constant Power Edit screen, and after inputting new values, press F3 to make those changes effective and jump back to Constant Power Screen. Or press F4 to ignore the changes and jump to Constant Power Exit.

```
Constant Power Edit
Voltage Limit: 0.0V↕
Current Limit: 0.0A Update ⏎
Power Limit: 0.0kW Exit Pwr ⏎
```

From Constant Power Exit, F1 cancels the command to exit and jumps back to Constant Power screen, or F4 exits Constant Power and jumps to Home Menu Page 1 with the Voltage, Current, and OVP values as set. (See Menu Map Section 3.7.8).

```
Constant Power Exit Cancel ⏎
Set Volt: 0.0V↕
Set Curr: 0.0A
Set OVP: 88.0V V/I Mode ⏎
```

3.8.6 Home Timeout

The display jumps to this screen when the system has been idle for 30 seconds. Press Escape or F4 to return to Home Menu Page 1.



3.8.7 Display Brightness

Navigate from Home Menu Page 2, F1; use NavPad to dim or increase the brightness. F1 saves the adjusted setting for the remainder of the session and for future power-ups. F4 maintains the setting for the remainder of the session and returns the brightness to its previously saved level at next power-up.

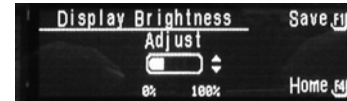

3.8.8 Lock Key

To prevent changes due to accidental pressing of the keys, Lock the keys from Home Menu Page 2, F2. This screen appears until F4 is pressed; a confirmation screen will appear with instructions to press Enter to unlock keys (see Section 3.7.12, Other Screens) before returning to Home Menu.



NOTE: Lock Key only works while in the normal constant Voltage or constant Current mode.

3.8.9 Language

The Language submenu allows the user to change the default language for the menu selections. To select this menu, from Home Menu Page 2 press F3 to go to the Language Menu and select a language to work in. Pressing F1 will save the selection and exit the Language Menu. The next time the unit is powered up it will be in the last saved language. Pressing F4 will keep the selected language only for the remainder of the session and will revert to the previously saved language at next power-up.



Foreign Language

If the unit is set to a language foreign to the user, press the escape key until Home Menu Page 1 appears. (Even in a foreign language, the Voltage and Current values will still display: value with the letter V and value with the letter A, respectively. Also, there will be only one interscreen navigation arrow, which is located at the bottom of the screen). Use the NavPad to scroll down to Home Menu

Page 2 (there will be two interscreen navigation arrows, one at the top and one at the bottom of the screen). Press F3, which jumps to the Language Menu, and then use the NavPad to scroll to the user's native language.

3.8.10 Info

The Supply Information screen shows the date that the unit was last calibrated, Model Number and Serial Number of the unit, and version of the software. To access this screen, from Home Menu Page 2 press F4.

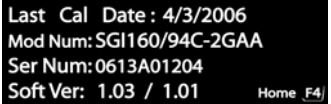

```

Last Cal Date: 4/3/2006
Mod Num: SGI160/94C-2GAA
Ser Num: 0613A01204
Soft Ver: 1.03 / 1.01
Home F4
  
```

3.8.11 Remote

Remote (F provides screens for either the Ethernet option or the GPIB option. The following describes the Remote Menu pages for Ethernet and for GPIB.

ETHERNET

The Ethernet Remote Menu displays the power supply's Ethernet MAC address, which cannot be edited. Access the menu from Home Menu Page 3, F1 key. This menu also displays in the IP IN USE: line, the IP address presently in use from either a static IP setting or from the DHCP server, depending on how assigned. The Baud Rate is editable via the NavPad; changing it here changes the rear panel RS232 SCPI baud rate. The initial factory setting is 19200.

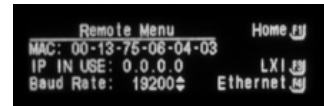

```

Remote Menu Home F1
MAC: 00-13-76-06-04-03
IP IN USE: 0.0.0.0 LXI F3
Baud Rate: 19200 Ethernet F2
  
```

LXI

The LXI submenu (F3 from the Remote Menu) displays two settings required by the LXI requirements.

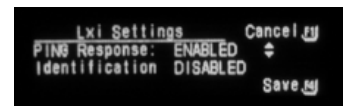

```

Lxi Settings Cancel F1
PING Response: ENABLED
Identification DISABLED Save F2
  
```

PING Response: enables or disables the power supply's response to a ping packet sent from a remote Ethernet host. To change the setting to either ENABLED or DISABLED, move the editing arrows to the PING Response: line by pressing NavPad left/right, and then change the setting by pressing NavPad up/down. Press F1 to Cancel the change and return to the Remote Menu screen, or press F4 to Save the changed setting.

Identification controls the LAN LED on the power supply's rear panel. ENABLED causes the LAN LED to flash for visual identification. DISABLED causes the LAN LED to be steady-lit to indicated the power supply's connected status. To change the setting, move the editing arrows to the Identification field by pressing NavPad left/right, and then change the setting by pressing NavPad up/down. Press F1 to Cancel the change and

return to the Remote Menu screen, or press F4 to Save the changed setting.

ETHERNET

The Ethernet submenu (F4 from the Remote Menu) displays the Primary (Pri Config) and Secondary (Sec Config) Ethernet configurations, both of which are editable. It also provides further submenus to change the Server Listener Port (F3) and the Static IP address (F4).



The Primary configuration is attempted at power-up, and if it fails, the system defaults to the Secondary configuration. However, both setting “DHCP-acquired” *and* selecting “Auto IP Enabled” together in the Primary configuration, prevents the power supply from trying the Secondary configuration.

Useful configurations are described as follows:

Pri Config STATIC IP

Sec Config DHCP

At power-up the power supply will assign itself the configured static IP address. If no other device is using the IP address, the power supply continues with that static IP address. If some other device is using that address, the power supply will move to Secondary and attempt to acquire an IP address from a DHCP server repeatedly until it gets an address.

Pri Config STATIC

Sec Config DHCP+AUTOIP

At power-up the power supply will assign itself the static IP address. If no other device is using the IP address, the power supply continues with that static IP address. If some other device is using that address, the power supply will move to secondary and attempt to acquire an IP address from a DHCP server. If it cannot find a DHCP server to assign an address, it will assign itself a link-local address. If no other device is using that link-local address it will use it for 5 minutes minimum. At that time, if it is already in communication with some other device, it will hold onto that link-local address until the communication is finished and then retry DHCP. Then, if DHCP is not available, the power supply will revert to the last successful link-local address for another 5 minutes minimum.

Pri Config DHCP

Sec Config STATIC

At power-up the power supply will attempt to acquire an IP address from a DHCP server. If it cannot find a DHCP server to assign an address, the power supply will move to Secondary and assign itself the static IP address. If no other device is using the IP address, the power supply continues with that static IP address. If some other device is using the static IP address, the power supply will move back to Primary and start the entire operation again.

Pri Config DHCP+AUTOIP

Sec Config (will not be used with the above Pri config)

At power-up the power supply will attempt to acquire an IP address from a DHCP server. If it cannot find a DHCP server to assign an address, it will assign itself a link-local address. If no other device is using that link-local address, it will use it for 5 minutes minimum. At that time, if it is already in communication with some other device, it will hold onto the link-local address until the communication is finished and

then retry DHCP. If DHCP is not available, the power supply will revert to the last successful link-local address for another 5 minutes minimum.

PORT

The Server Port Menu is used to set the network TCP/IP socket listening port. Valid values are 1025 to 65535. The factory default setting is 9221. To change, press NavPad up/down or use the numeric keys to enter specific values. Press F4 to save the change or press F1 to return to the Ethernet menu without changing anything.



STATIC IP CONFIGURATION

The Static IP menu allows manual setting not only of the IP address, but also subnet mask, gateway and Domain Name Server (DNS) server. The four IP octets in each field are edited one at a time. Navigate to each octet by pressing NavPad left/right, then change the value by either pressing NavPad up/down or by entering a specific value with the numeric keys.



IP – input any standard IP address. (Factory setting is 192.168.0.200). Press F4 to save the changes or press F1 to return to the Ethernet menu without changing anything.

MASK – input a value that identifies which network segment your power supply is on, consisting of 4 whole numbers, each ranging from 0 through 255, separated by periods. (Factory setting is 255.255.255.0, a class-C network subnet mask). Press F4 to save the change or press F1 to return to the Ethernet menu without changing anything.

GATE – input the IP Address of any gateway that stands between the instrument and any other network entities that communicate with the power supply. (No factory setting). Press F4 to save the change or press F1 to return to the Ethernet menu without changing anything.

DNS – input an IP address for the Domain Name System (DNS) server. Press F4 to save the change or press F1 to return to the Ethernet menu without changing anything.

GPIB

The Remote Menu for GPIB option (Home Page 3, F1) allows setting of the GPIB address and the baud rate for the RS232C interface. Use the NavPad to set the GPIB address from 1 to 30, and the RS232C baud rate from 2400 to 19200. Pressing F1 saves the new values in non-volatile memory so that they will be remembered after power down. Pressing F4 keeps the selected values only

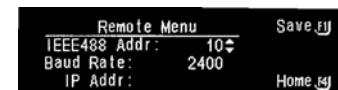

until the unit is power down; then, at next power up, the previously saved settings will be restored.

REMOTE OPERATION SCREENS

If the unit is being controlled remotely via Ethernet, GPIB or RS232C interface, special screens may appear during operation. The following describes those displays:

- Remote Mode Primary display shows the actual values for Volts and Watts. F4 jumps to Home Timeout screen.
- Remote Mode Power display shows the set points on the first line, actual values for Voltage and Current on the second line, and at the bottom, the actual value for Watts with a bar graph of its percent of full-scale power. F4 jumps to the Constant Power screen.
- Remote Mode Sequence display shows what sequence is running. F4 jumps to the local Sequence Run screen.

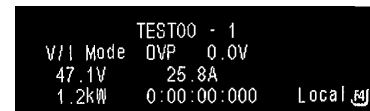
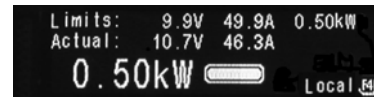

3.8.12 System

The System submenu allows the user to display the total system current when the unit is being paralleled with other SG series supplies.

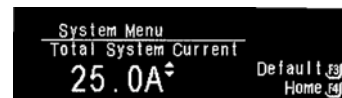

From Home Menu Page 3, press F2 to enter the System Menu. Determine the Total System Current by adding the maximum current rating of all supplies in parallel. Use NavPad or the KeyPad "0-9" to enter the appropriate value. F3 resets Total System Current to the supply default value; F4 keeps the displayed value and jumps to Home Menu Page 1.

3.8.13 Warning Screens

There are two warning screens that may appear during the course of operation:



Hard Fault warns that a hardware fault has occurred. This may be caused by an over-temperature condition, or a module fault occurring. These conditions may clear themselves, however, if they continue to occur after pressing the F4 (ClrFault) key, contact the factory for service assistance.



OVP Fault occurs when the output voltage of the supply exceeds the OVP setting. When this occurs the output is disabled, and voltage and current output go to 0. To clear the display, press F1 (Clr OVP). The display will return to Home Menu Page 1, and the output will remain disabled.

NOTE: *It is important to correct the condition that caused the OVP, prior to enabling the output.*

3.9 Basic Operation and Output Verification

The SGI Series power supply is shipped from the factory configured for local (Front Panel) Voltage/Current/Oversvoltage protection control and local voltage sensing. The ANALOG CONTROL connector is supplied with a mating connector with remote output ON/OFF jumpered for ON (terminal 5 shorted to terminal 6).



WARNING!

The power-up factory default state is output enabled.

At first-time power up, the Voltage and Current are programmed to zero. The Oversvoltage protection is set to maximum and the Output Condition status is **OFF**.

This section provides an overview and examples of front panel programming, Default Programming menu operation and initial functional tests for the SGI Series power supply.

3.9.1 Initial Setup

Before connecting the unit to an AC outlet, ensure that the front panel ON/OFF power switch is in the **OFF** position. Check the ANALOG CONTROL (J1) mating connector on the rear panel to verify that pins 5 and 6 (Remote Output On/Off) are shorted together. This is the default configuration installed from



the factory. This jumper allows the output of the supply to be enabled from the front panel when the Output On/Off button is pressed. Apply power to the AC mains input.

3.9.2 Default Programming Menu

The following subsections describe operation in Voltage Mode, in Current Mode, and OverVoltage Protection (OVP) Mode.

VOLTAGE MODE OPERATION

In Voltage mode operation the output voltage is regulated at the selected value while the output current varies with the load requirements. To verify operation in Voltage mode, follow these steps:



1. Connect a digital voltmeter (DVM) across the rear panel positive and negative output terminals, observing the correct polarity. Make sure the DVM is in the dc voltage mode and the range is adequate to handle the full-scale voltage of the power supply.
2. Turn on the power supply. When the supply reaches the Home menu page 1, enable the output by pressing “Output On/Off.”
3. Enter the Default Programming menu by pressing , , or  key.
4. Program the Current to 10% of full-scale output (this sets the current limit at a nominal setting above 0 Amps and forces the supply into voltage mode). See Section 3.8.1 for more details on programming.
5. Navigate to Voltage programming. With the Editing Arrow adjacent to “Set Volt”, press and hold the NavPad up arrow and observe both the front panel voltage display and the output of the DVM begin to accelerate up. The minimum range should be from 0V to the maximum rated voltage output of the supply. The front panel display and DVM readings should track within the accuracies of the meter and the front panel display.
6. Verify the front panel Voltage Mode indicator is on.
7. Program the Voltage and Current back to **zero**.
8. Turn the power supply off.

If Voltage mode operation did not function as indicated above, recheck the setup and perform the check again. If the function continues to fail, contact the factory for assistance.

CURRENT MODE OPERATION

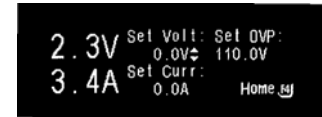

In Current mode operation the output current is regulated at the selected value while the output voltage varies with the load requirements. To verify operation in Current mode, follow these steps:





1. Connect a high current DC ammeter across the rear panel positive and negative output terminals, observing the correct polarity. Select wire leads of sufficient current carrying capacity and an ammeter range compatible with the units maximum rated output current.
NOTE: If a high current ammeter is not available, simply short the output terminals together. This will not harm the supply.
2. Turn on the power supply. When the supply reaches the Home menu page 1, enable the output by pressing "Output On/Off."
3. Enter the Default Programming menu by pressing , , or  key.
4. Program the Voltage to 10% of full-scale output (this sets the Voltage limit at a nominal setting above 0 Volts and forces the supply into current mode). See Section 3.8.1 for more details on programming.
5. Navigate to Current programming. With the Editing Arrow adjacent to "Set Curr", press and hold the NavPad up arrow and observe both the front panel current display and the output of the DC ammeter begin to accelerate up. The minimum range should be from 0 Amps to the maximum rated current output of the supply. The front panel display and DC ammeter readings should track within the accuracies of the meter and the front panel display.
6. Verify the front panel Current Mode indicator is on.
7. Program the Voltage and Current back to **zero**.
8. Turn the power supply off.
9. Allow 5 minutes for the output capacitors to discharge and disconnect the ammeter or short from the output terminals.
10. If Current mode operation did not function as indicated above, recheck the setup and perform the check again. If the function continues to fail, contact the factory for assistance.

OVERVOLTAGE PROTECTION

The Overvoltage Protection (OVP) function allows the supply to shutdown the output when it exceeds a preset voltage limit. This may be used to protect sensitive circuits or loads from damage caused by an excessive voltage on the output of the supply. To verify OVP operation, follow these steps:

1. Make sure there is nothing connected across the output terminals.
2. Turn on the power supply. When the supply reaches the Home Menu Page 1, enable the output by pressing "Output On/Off."
3. Enter the Default Programming menu by pressing , , or  key.

4. Program the Current to 10% of full-scale output (this sets the current limit at a nominal setting above 0 Amps and forces the supply into voltage mode). See Section 3.8.1 for more details on programming.
5. Navigate to OVP (Overvoltage) programming. The factory default setting is approximately 110% of the maximum rated output of the supply. With the Editing Arrow adjacent to “Set OVP”, press and hold the NavPad **down** arrow and observe the front panel voltage display accelerate down. Release the NavPad **down** arrow when the OVP is programmed to about 80-90% of the maximum rated output voltage value.
6. Navigate to Voltage programming. With the Editing Arrow adjacent to “Set Volt”, press and hold the NavPad **up** arrow and observe the front panel voltage display accelerate up. When the output voltage exceeds the OVP trip point the OVP Warning screen will be display with the voltage level reached at OVP trip. The Output Condition will be programmed to **OFF**, and the voltage, current, and OVP settings will retain their previous settings.
7. Press (F4) and the fault screen will clear after 4 seconds. The Home Menu Page 1 will be displayed, and the output will remain disabled.
8. Enter the Default Programming menu by pressing , , or  key.
9. Program the OVP setting as appropriate for the application as shown above. If OVP will not be used, then “OVP set” programming may be set at maximum, approximately 110% of the rated output voltage of the supply.

If OVP mode did not function as indicated above, recheck the setup and perform the check again. If the function continues to fail, contact the factory for assistance.

3.9.3 Floating and Polarized Output

The SGI Series supply can be set up for a Positive or Negative supply, as well as standard operation as a floating output supply.

FLOATING OUTPUT

The output terminals are normally floating from chassis ground. No extra steps or connections are required for a floating output.

POSITIVE SUPPLY SETUP

Attach the negative output terminal to the supply chassis. The output reference is now chassis ground. When the output voltage is set or programmed, the supply will output a positive potential from chassis ground.

NEGATIVE SUPPLY SETUP

Attach the Positive output terminal to the supply chassis. The output reference is now chassis ground. When the output voltage is set or programmed, the supply will output a negative potential from chassis ground.



CAUTION!

Floating the negative output terminal floats the power supply's internal control circuitry common level to the same potential as the negative output terminal. On a standard non-isolated supply the common of the analog control connector (J1) floats at the same potential as the negative output terminal. Damage may occur if the non-isolated analog control connector of a supply is connected to an external ground referenced input/output device. Such a connection creates ground loop currents. To correct ground loop problems the Isolated Analog option is advised in order to isolate the external ground reference signals from the internal control circuitry of the supply.

3.9.4 Remote Analog (J1) Control

The Analog Control connector on the rear panel allows the unit to be configured for different operating configurations: local and remote current programming, local and remote voltage programming, current and voltage output monitoring, output enable/disable, etc. The setup and operating requirements of each configuration are provided in this section.

The SGI also has the capability of providing summing of remote analog input with the set values on the front panel (or programmed values via the digital interface) for voltage, current and OVP. This capability provides a means to modulate a set value with the signal on the voltage, current and OVP analog input. If the user only desires to control the unit with the analog input, all the front panel values (V/I/OVP) or digital settings should be set to zero.

ISOLATED ANALOG CONTROL (OPTION)

The Isolated Analog Control uses the same Analog Control connector (J1). This option fully isolates remote control signals and allows control of units not connected to a common ground. Control ground is isolated from power ground, which protects against potential damage from systems with high electrical noise or large ground loop currents.

Note: Some standard analog programming signals may not be available with this option. See Table 1.2.2, *Electrical Characteristics*, for details.



CAUTION!

This option is not intended to allow operation of the power supply at excessive voltages. Refer to Section 2 INSTALLATION for maximum terminal voltages.

Following are Figure 3-6 showing the connector's pin-out diagram, and Table 3.1 defining the Analog Control connector designations and functions:

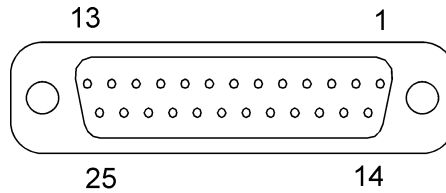



Figure 3-6. Analog Control Connector (J1) Pin-out



CAUTION!

If standard analog programming is used, note the programming return (J1-6 & J1-24) is at the same potential as the negative output terminal of the power supply. Observance of return connections should be made with respect to input programming signal equipment. Improper connection may result in ground loops and as a result internal power supply damage may occur. (Output current then flows to chassis by means of external connection to the J1 common (J1-6 & J1-24)).

Designator	Schematic Symbol	Electrical Chars.	Functional Description
1	ISO ON/OFF	$Z_{in} \sim 6 \text{ k}\Omega$	Isolated remote output on/off. Externally supplied AC/DC voltage source for on/off control. A positive (+) 12 to 240 VAC or 6 to 120 VDC voltage will enable the output, i.e., turn on the output of the supply. This input control is optically isolated from the power supply circuit up to 500 VDC. Circuit return Pin 2 (ISO RTN). See Section 3.13.
2	ISO RTN	—	Isolated circuit return used with isolated on/off control J1-1 and J1-14.
3	REM OV SET	$Z_{in} \sim 20 \text{ k}\Omega$	Remote overvoltage set. A remote signal sets the overvoltage trip level. 0.25-5.5 VDC = 5-110%. Apply a 10.5 VDC to 13.3 VDC signal for 4 seconds to reset an OVP condition. Circuit return Pin 6 (COM). See Section 3.14.
4	VP RTN	$Z_{in} \sim 10 \text{ k}\Omega$	Voltage programming return. Used with J1-9, J1-15 or J1-21 and must be referenced to Pin 6 (COM) circuit common.
5	ON/OFF	Must sink ~1mA to enable	Remote output on/off. Switch/relay contacts or a direct short between this terminal and Pin 6 (COM) circuit common, enables the output, i.e., turns on the output of the supply See Section 3.13.
6	COM †	-	Circuit common. Electrically equal to Pin 24. Same potential as the negative output terminal.
7	I MON	$Z_{out} \sim 100\Omega$	Output current monitor. 0-10 VDC equals 0-100% rated current. Minimum load resistance 10k Ω . Circuit return Pin 6 (COM).
8	Not Used		
9	VP 5V	$Z_{in} \sim 10\text{k}\Omega$	Remote voltage programming using a 0-5 VDC source. Do not exceed 13.3 VDC. Circuit return Pin 4 or Pin 20 (VP RTN). See Section 3.11.
10	IP 5V	$Z_{in} \sim 10\text{k}\Omega$	Remote current programming using a 0-5 VDC source. Do not exceed 13.3 VDC. Circuit return Pin 23 or Pin 25 (IP RTN). See Section 3.10.
11	Not Used		
12			
13			
14	ISO TTL/CMOS	$Z_{in} \sim 2.2\text{k}\Omega$	Isolated TTL/CMOS on/off control. A high state TTL/CMOS voltage enables the output, i.e., turns on the output of the supply, and a low state or open connection disables the output, i.e., turns off the output of the supply. Circuit return Pin 2 (ISO RTN). See Section 3.13.
15	VP 10V	$Z_{in} \sim 20\text{k}\Omega$	Remote voltage programming using a 0-10 VDC source. Do not exceed 25 VDC. Circuit return Pin 4 or Pin 20 (VP RTN). See Section 3.11.
16	IP 10V	$Z_{in} \sim 20\text{k}\Omega$	Remote current programming using a 0-10 VDC source. Do not exceed 25 VDC. Circuit return Pin 23 or Pin 25 (IP RTN). See Section 3.10.
17	FAULT	$Z_{out} \sim 100\Omega$	Fault state output. A high state (approximately +10 VDC) indicates a converter, temperature or bias supply fault, and the LED on the front panel will illuminate. Circuit return Pin 6 (COM).

Designator	Schematic Symbol	Electrical Chars.	Functional Description
18	S/D FAULT	Zout ~ 100Ω	Shutdown fault. This terminal goes to high state in the event of converter, temperature, overvoltage or bias supply fault. A 7 VDC to 13.3 VDC signal can be applied to this pin to shutdown the output of the unit. An 8 VDC minimum output signal is provided into a 10 kΩ minimum load, in the event of an internally generated shutdown. Circuit return Pin 6 (COM). See Section 3.15.
19	V MON	Zout ~ 100Ω	Output voltage monitor. 0-10 VDC equals to 0-100% rated voltage. Minimum load resistance 10kΩ. Circuit return Pin 6 (COM).
20	VP RTN	Zin ~ 10Ω	Voltage programming return. Used with J1-9, J1-15 or J1-21 and must be referenced to Pin 6 (COM) circuit common.
21	VP RES *	~ 10.8V compliance	1 milliamp current source for remote voltage programming using resistance. 0-5k ohm resistor referenced to Pin 4 or Pin 20 (VP RTN) will program the output voltage from 0-100%. See Section 3.11.
22	IP RES *	~ 10.8V compliance	1 milliamp current source for remote current programming using resistance. 0-5k ohm resistor referenced to Circuit return Pin 23 or Pin 25 (IP RTN) will program the output current from 0-100%. See Section 3.10.
23	IP RTN	Zin ~ 10kΩ	Current programming return. Used with J1-10, J1-16 or J1-22 and must be referenced to Pin 6 (COM) circuit common.
24	COM †	-	Circuit common. Electrically equal to Pin 6. Same potential as the negative output terminal.
25	IP RTN	Zin ~ 10kΩ	Current programming return. Used with J1-10, J1-16 or J1-22 and must be referenced to Pin 6 (COM) circuit common.

Table 3.1 Analog Control Connector (J1), Designations and Functions

† Control ground is isolated from power ground with the isolated analog control (option). See Section 3.9.4

* Signals not available with isolated analog control (option).



CAUTION!

If standard analog programming is used, note the programming return (J1-6 & J1-24) is at the same potential as the negative output terminal of the power supply. Observance of return connections should be made with respect to input programming signal equipment. Improper connection may result in ground loops and as a result internal power supply damage may occur. (Output current then flows to chassis by means of external connection to the J1 common (J1-6 & J1-24)).

3.10 Remote Current Programming

Remote current programming is summed with the front panel or digital setting (see Section 3.9.4). Remote current programming is used for applications that require the output current be programmed (controlled) from a remote source. An external resistance or external voltage source may be used as a programming device. When using remote current programming, a shielded, twisted-pair, hookup wire is recommended to prevent noise interference with programming signals.

3.10.1 Remote Current Programming Using Resistance

The resistance coefficient for remote current programming is 5k ohms/100% rated output with respect to terminal J1-23 (IP RTN). The programming current from terminal J1-22 (IP RES) is factory set for 1 milliampere. This yields a coefficient of 1.0% of rated output current for each 50 ohms. If multiple switches or relays are used to program different levels, make-before-break contacts are recommended. Note that if an external resistance is used for remote programming, the current programming return (IP RTN), terminal J1-23, must be connected directly to or within ± 3 volts (see note) of the power supply common terminal, J1-24. See Figure 3-7 for connection requirements.

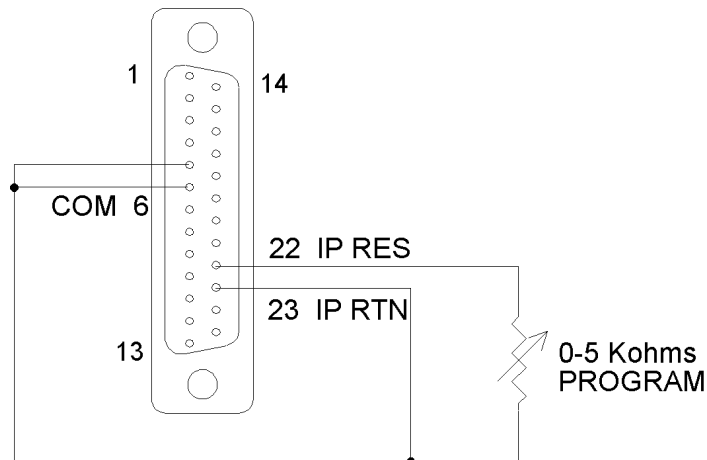

Figure 3-7. Remote Current Programming Using Resistance

3.10.2 Remote Current Programming Using a 0-5 VDC or 0-10 VDC Voltage Source

A DC voltage source for remote current programming is connected between J1-10 (IP 5V) or J1-16 (IP 10V) and the return terminal J1-23 (IP RTN). Note that the return terminal J1-23 (IP RTN) must be referenced directly to or within $\pm 3V$ (see note) of the power supply common, J1-24. The voltage coefficient for 5V remote current programming is 50 millivolts = 1% of rated output, i.e., for a 300 amp model, each 50 millivolts of programming voltage equals 3 amps of output current. The voltage coefficient for 10V remote current programming is 100 millivolts = 1% of rated output, i.e., for a 300 amp model, each 100 millivolts of programming voltage equals 3 amps of output current. See Figure 3-8 for connection requirements.

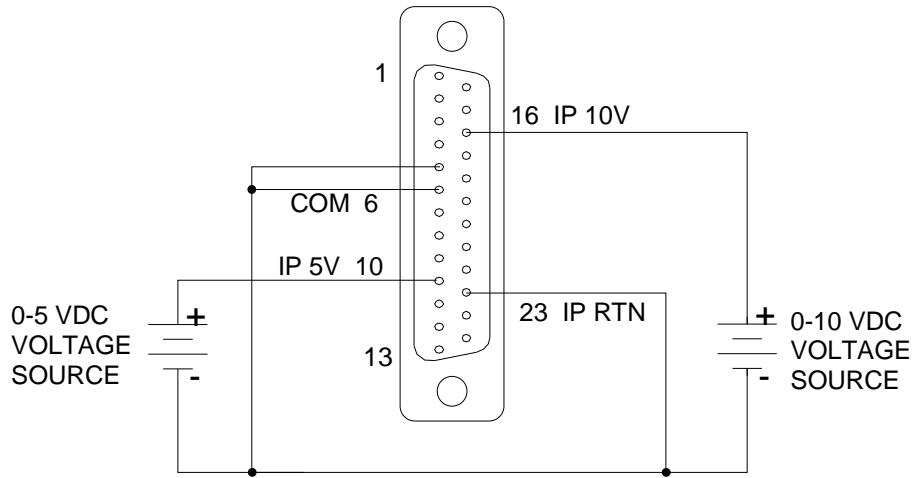

Figure 3-8. Remote Current Programming Using 0-5 VDC or 0-10 VDC Voltage Source

3.11 Remote Voltage Programming

Remote voltage programming is summed with the front panel or digital setting (see Section 3.9.4). Remote voltage programming configuration is used for applications that require the output voltage be programmed (controlled) from a remote source. An external resistance or external voltage source may be used as a programming device. When using remote voltage programming, a shielded, twisted-pair, hookup wire is recommended to prevent noise interference with programming signals.

3.11.1 External Voltage Programming Using Resistance

The resistance coefficient for remote voltage programming is 5k ohms/100% of rated output voltage with respect to the VP RTN, J1-20. The programming current from terminal J1-21 (VP-RES) is factory set to 1 milliampere. This yields a coefficient of 1.0% of rated output voltage for each 50 ohms. If multiple switches or relays are used to program different levels, make-before-break contacts are recommended. Note that if an external resistance is used for remote programming, the voltage programming return (VP RTN), terminal J1-20, must be connected directly to or within ± 3 volts (see note) of the power supply common terminal, J1-24. See Figure 3-9 for connection requirements.

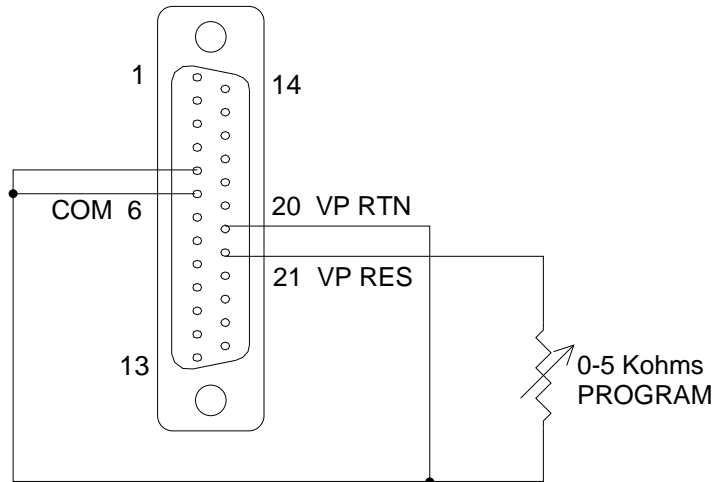

Figure 3-9. Remote Voltage Programming Using Resistance

3.11.2 External Voltage Programming Using a 0-5 VDC or 0-10 VDC Voltage Source

A DC voltage source for remote voltage programming is connected between J1-9 (VP 5V) or J1-15 (VP 10V) and the return terminal J1-20 (VP RTN). Note that the return terminal (VP RTN) must be referenced directly to or within $\pm 3V$ (see note) of the power supply common, J1-24. The voltage coefficient for 5V remote voltage programming is 5 volts = 100% of rated output voltage. The voltage coefficient for 10V remote voltage programming is 10 volts = 100% of rated output voltage. See Figure 3-10 for connection requirements.

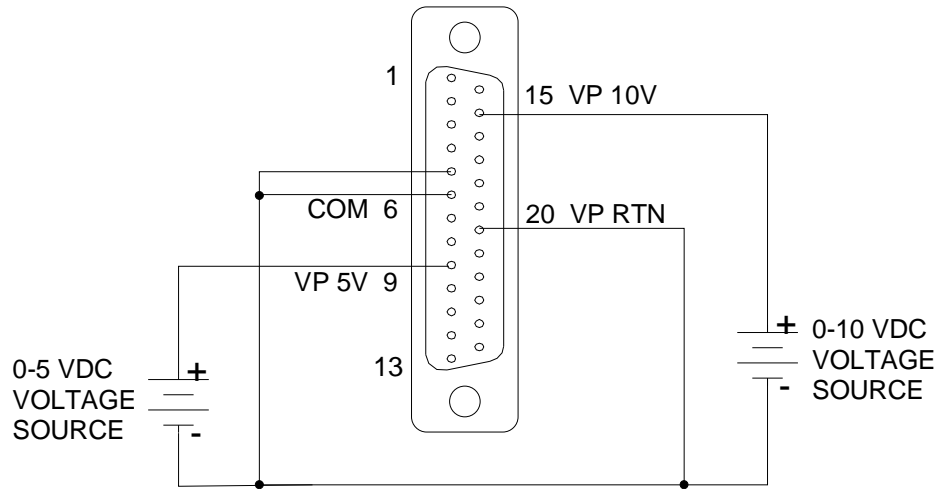

Figure 3-10. Remote Voltage Programming Using 0-5 VDC or 0-10 VDC Voltage Source

3.12 Remote Sensing

Remote voltage sensing is recommended at all times, whether the sensing leads are connected to the load or directly to the output terminals. Remote sensing at the load provides the best load regulation.

In applications where the load is located some distance from the power supply, or the voltage drop of the power output leads significantly interferes with load regulation, remote voltage sensing should definitely be used.

The voltage accuracy specifications are valid only with remote sense connected. Disconnecting the remote sense leads will introduce an error, with the output voltage increasing. The error occurs because an additional resistance (PTC local resistor network in Figure 3-11) is added in the circuit of the resistor divider for voltage sensing, to provide the default local sensing of the output voltage at the output terminals. When remote sense is connected the PTC local resistor network is short-circuited, effectively removing it from the circuit.

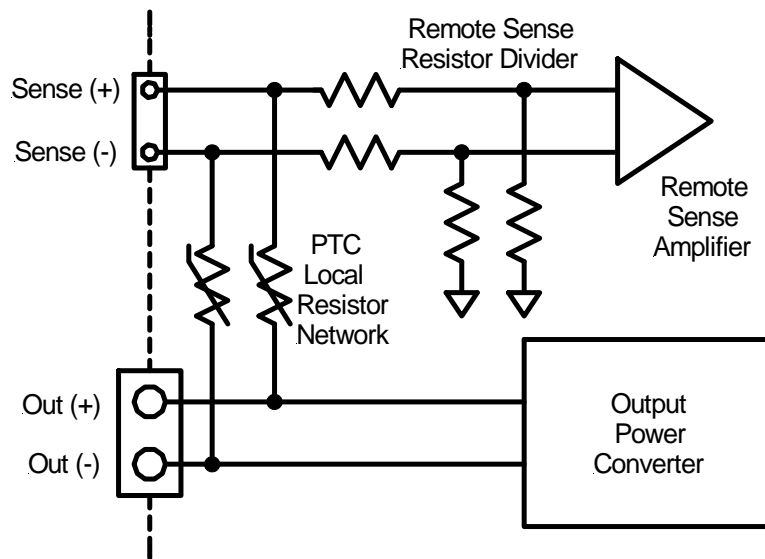

Figure 3-11. Local/Remote Voltage Sensing



CAUTION!
 If the power supply is operated with load power lines disconnected and sensing line connected, internal power supply damage may occur. (Output current then flows through sensing terminals).

To use remote voltage sensing, connect the power supply as described below. See Figure 3-12 for connection requirements.

Connect sensing leads from the load positive to J3-1 and the load negative to J3-2 (load negative to J3-3 on 800V models). A shielded, twisted-pair, hookup wire is recommended to avoid potential noise interference.

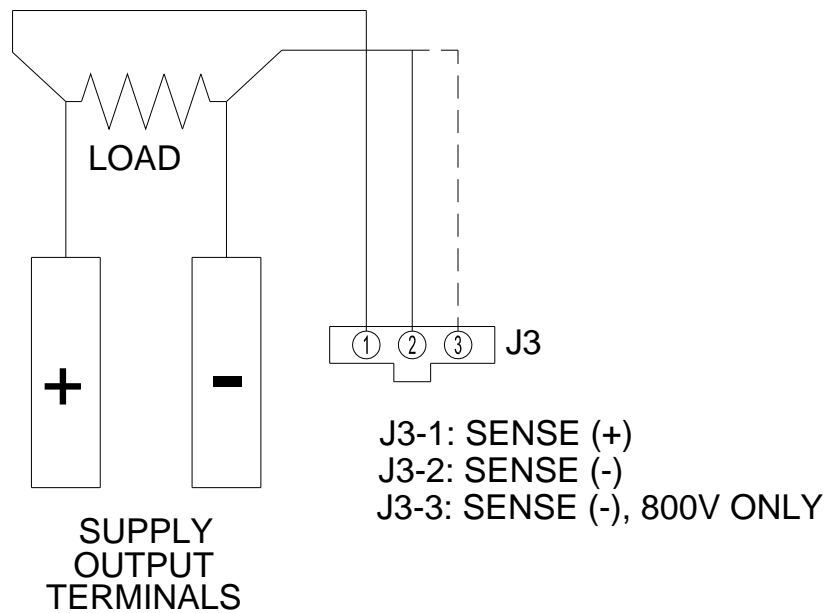

Figure 3-12. Remote Sensing Operation at the Load

3.13 Remote Output On/Off Control

Remote output on/off control may be accomplished by contact closure or by an isolated external AC/DC or TTL/CMOS voltage source.

1. Remote output on/off by contact closure. Output is on when contacts (J1-5 and J1-6) are closed. See Figure 3-13 for connection requirements.

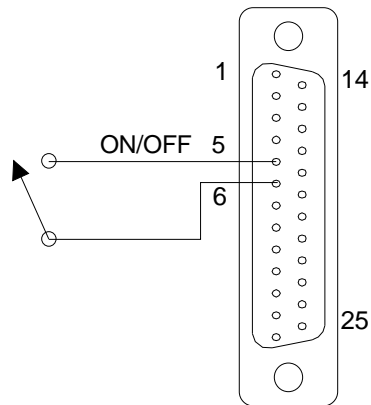

Figure 3-13. Remote Output On/Off Control by Contact Closure

2. Remote output on/off control may be accomplished by an external 12 to 240 VAC or 6 to 120 VDC or TTL/CMOS source. Application of AC/DC or high state TTL/CMOS voltage will turn on the power supply. See Figure 3-14 and Figure 3-15 for connection requirements.

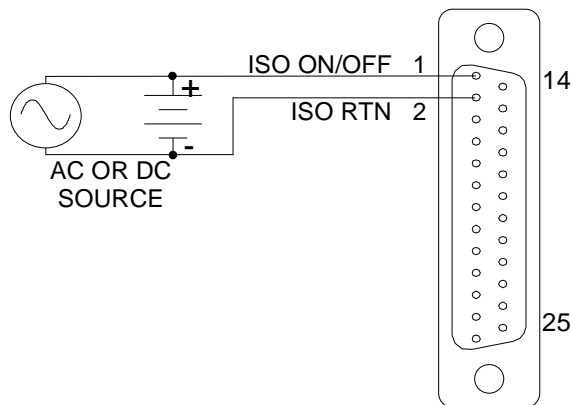

Figure 3-14. Remote Output On/Off Using Isolated AC or DC Voltage Source

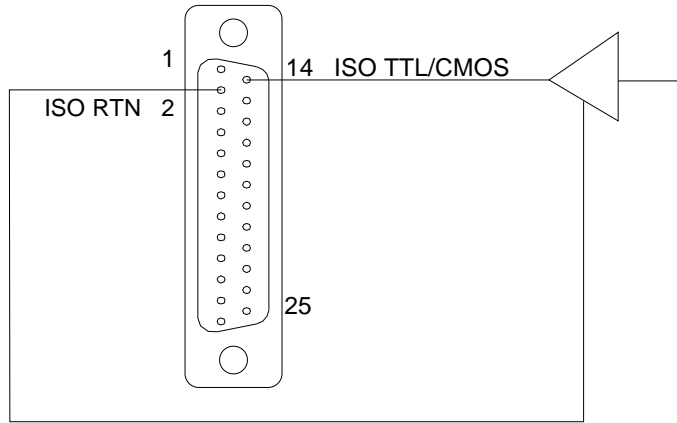

Figure 3-15. Remote Output On/Off Using Isolated TTL/CMOS Voltage Supply

3.14 Remote Overvoltage Setpoint



CAUTION!

Do not program the remote overvoltage set point greater than 10% (5.5V) above the power supply rated voltage (except as noted) as internal power supply damage may occur.

Remote OVP programming is summed with the front panel or digital setting (see Section 3.9.4). A remote DC voltage source can be connected externally between terminals J1-6 (COM) and J1-3 (REM OV SET) to set the output overvoltage trip level. A 0.25-5.5 VDC signal equals 5-110% of rated output voltage. See Figure 3-16 for connection requirements.

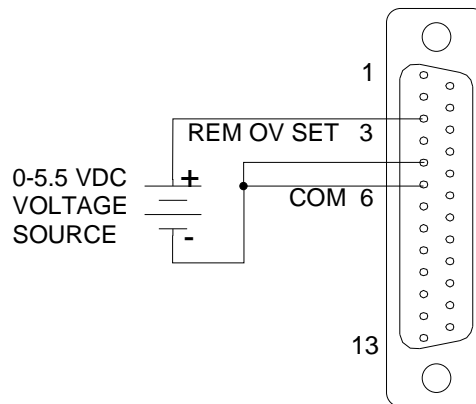

Figure 3-16. Remote Overvoltage Set Using DC Voltage Source

Note: To reset an OVP externally, apply a 10.5–13.3 VDC signal to J1-3 for a minimum of four (4) seconds.

3.15 Remote Shutdown (S/D)

A remote +12 VDC voltage can be connected externally between terminals J1-18 (S/D Fault) and J1-24 (COM) to disable, i.e., shut down the output of the power supply. Disabling or opening the +12 VDC signal will allow the unit to revert to normal operation.

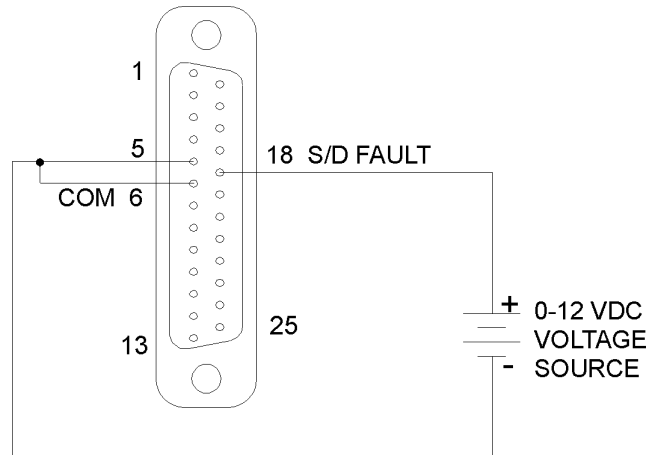

Figure 3-17. Remote Shutdown Using DC Voltage Source

3.16 Parallel and Series Operation

The following modes of operation are used for applications requiring more current or voltage than is available from a single power supply. To meet the requirements for greater output voltage or current, two supplies may be connected in series or up to five connected in parallel.

3.16.1 Parallel Operation

In order to connect up to five power supplies in parallel, use a “Master/Slave” daisy-chain wiring configuration as follows (refer to Figure 3-18):

(Note that there are two separate 9-pin connectors on the upper left rear panel of each power supply, marked “PAR OUT” and “PAR IN”).

1. Beginning with the power supply designated (by you) as the Master power supply, use an interface cable (P/N 890-453-03) to connect the PAR OUT connector on the designated Master power supply to the PAR IN connector on the second power supply (Slave 1).
2. On the second power supply (Slave 1), use another interface cable to connect the PAR OUT connector to the third power supply's (Slave 2) PAR IN connector. Continue these interconnections up to a maximum of 5 power supplies.
3. Connect the Positive output terminals of all the power supplies and the Load.
4. Connect the Negative output terminals of all the power supplies and the load.
5. Confirm that there are no shorts between the Positive and Negative output terminals.
6. Referring to Figure 3-18, connect twisted pair cables as follows:

All slave units shall have twisted pairs from their SENSE terminals to their output terminals, as appropriate.

For **Remote** Sense, the master unit shall have a twisted pair from its own SENSE terminals to the Load's output terminals.

For **Local** Sense, the master unit shall have a twisted pair from its own SENSE terminals to its own output terminals.

Ensure that all twisted pair cables are as short as possible.

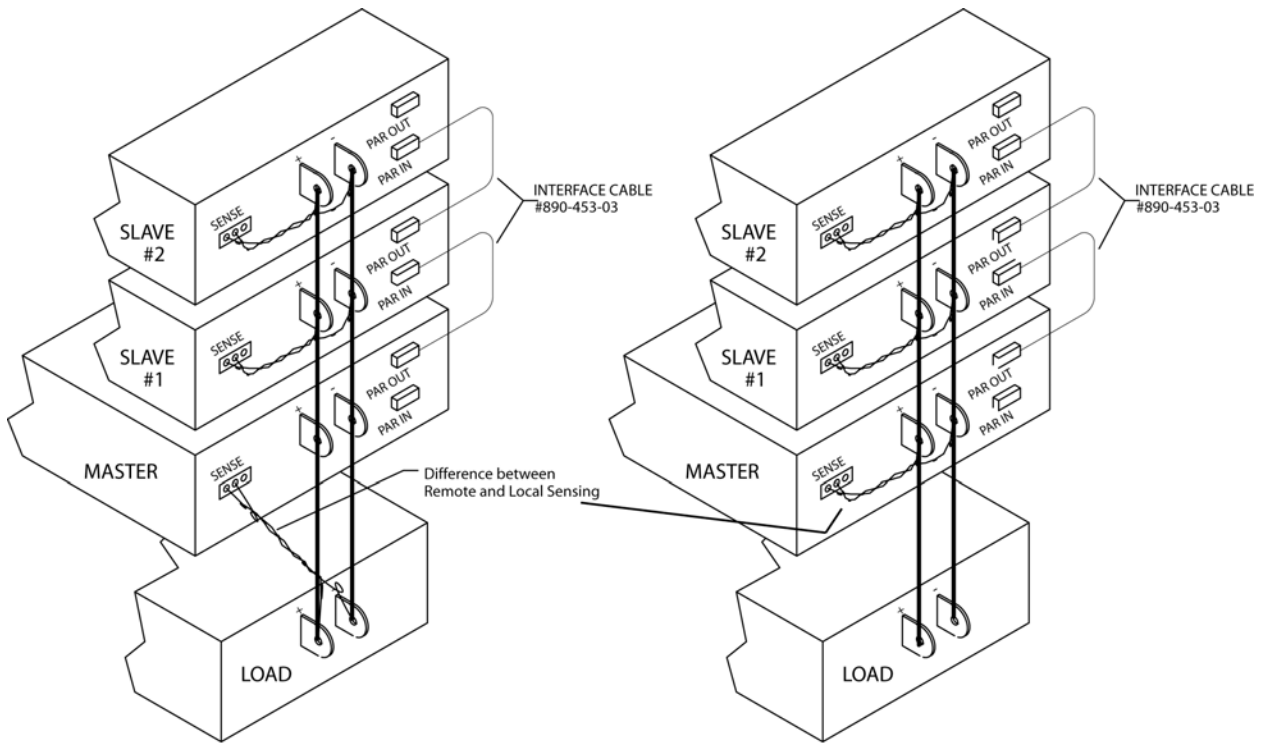

PARALLEL WITH REMOTE SENSING (block diagram)

PARALLEL WITH LOCAL SENSING (block diagram)

NOTE: The voltage display on the slave units will be slightly higher than the master unit. The twisted pair cable length must be as short as possible.

NOTE: The twisted pair cable length must be as short as possible.

Figure 3-18. Parallel and Remote/Local Sense Connections

Note: The OVP circuit remains active for all units in parallel operation. If the units are set to different OVP levels, the paralleled system will trip according to the lowest setting. For ease of use, adjust the OVP levels for the slaves to maximum and adjust the master OVP level to the desired setting.

3.16.2 Series Operation

Series operation is used to obtain a higher voltage single output supply using two units.

Connect the negative terminal (–) of one supply to the positive terminal (+) of the next supply of the same model. The total voltage available is the sum of the maximum voltages of each supply (add voltmeter readings).

Notes:

- Under no condition should the negative (–) output terminal of any power supply exceed 300V to Earth ground. This is limited by the creepage/clearance distances internal to the construction. If a higher output voltage range is required, contact the Sales Department or Customer Service for availability.
- The maximum allowable current for a series string of power supplies is the rated output current of a single supply in the string.
- Remote sensing should not be used during series operation.
- A free-wheeling diode (power diode capable of the maximum current of the series set connected in parallel, but reverse biased) is recommended to protect against sinking current into a supply should one supply be “ON” while the other is “OFF.” (Refer to Section 2.6.1).

SECTION 4

VERIFICATION AND CALIBRATION

4.1 Introduction

This section provides verification and calibration procedures for the SGI Series power supplies and isolated analog control (option). Please refer to the SG Programming Manual for calibration of display readback and remote digital programming DIA option.

4.1.1 Verification and Calibration Cycle

Annual calibration verification is recommended. Calibrate only as needed.

4.1.2 Preparation



WARNING!

Hazardous voltages exist on the rear of the supply. Great care must be taken to avoid both the input terminals, and while the supply is enabled, the output terminals. Only authorized personnel should perform this procedure.

Due to the importance of accurate readings to performance, only technically trained personnel should perform calibration procedures.

The calibration and adjustment procedures require two digital multimeters. To set up for the calibration procedures, first perform the following:

1. Remove prime AC power.
2. Connect the power supply to a precision current shunt (as shown in Figure 4-1 below) capable of a minimum of 10% above full rated output. A fan may be required to cool the shunt.

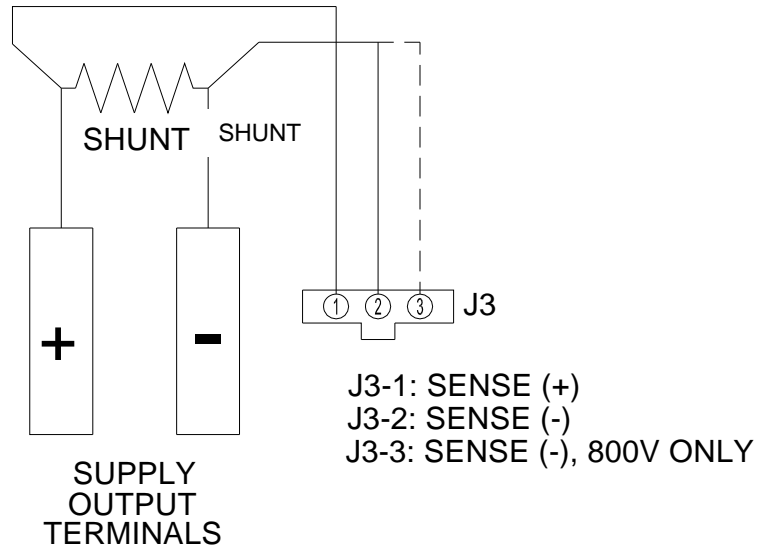

Figure 4-1. Precision Current Shunt

4.2 Standard Verification and Calibration Procedure

All calibration potentiometers are on circuit board assemblies located at the front of the chassis, and adjustments to the potentiometers are made from the top of the chassis. Refer to Figure 4-2 for the physical location of the potentiometers. Some of the models will require *partial* removal of the top cover of the chassis to gain access to the potentiometers. This is dependent on the type of chassis, and whether the Ethernet option is installed.

The 6U-chassis units and earlier 3U-chassis units have access holes in the top cover that allow adjustment of the calibration potentiometers without removing the top cover. However, if the Ethernet option is installed, some of the potentiometers are covered by a ribbon-cable. To adjust those potentiometers, the cover should be partially removed, and slid towards the rear of the chassis just enough to expose the location of the potentiometers, but with the cover still on top of the chassis. The ribbon-cable should then be carefully moved sufficiently to expose the adjustment screws of the potentiometers.

The latest 3U-chassis units do not have access holes in the top cover, and the top cover must be partially removed to perform calibration. The cover should be slid towards the rear of the chassis just enough to expose the potentiometers, but with the cover still on top of the chassis. If the Ethernet option is installed, a ribbon-cable must be moved, as described above for the 6U-chassis.

When a unit is configured with the Isolated Analog option, calibration must be first performed on that option (go to Section 4.3), before the Standard Verification and Calibration procedure of Section 4.2 is performed.

4.2.1 Current Mode

1. Set the SGI Series unit to operate in remote current programming mode using an external 0-5 VDC voltage source as shown in Figure 3-8 in Section 3.10, Remote Current Programming.
2. Attach a precision meter across the shunt Kelvin terminals.
3. Attach a precision meter in parallel with the voltage programming source.
4. Set the voltage source to $0.0V \pm 1mV$.
5. Apply AC power and press the "Output On/Off" button (see Section 3.2.1, Front Panel Controls and Indicators).
6. Set the programming voltage to $5.0V \pm 1mV$.
7. Verify the unit is set to $100\% \pm 0.8\%$ of full-scale output current. If necessary, adjust R69 for 100% of full-scale current on the shunt.
8. Set the programming source for $0.5V \pm 1mV$.
9. Verify the unit is set to $10\% \pm 0.8\%$ of full-scale output current. If necessary, adjust R55 for 10% of full-scale current on the shunt.
10. Repeat the steps above as required to obtain the required accuracy.

4.2.2 Voltage Mode

1. Disable AC power to the unit. Remove the current shunt from the output and verify that there is no load attached.
2. Remove the precision meter leads from the current shunt and apply them across the output terminals.
3. Set the SGI series unit to operate in remote voltage programming mode using an external 0-5 VDC voltage source as shown in Figure 3-10 in Section 3.11 Remote Voltage Programming.
4. Apply AC power and press "Output On" button (see Section 3.2.1, Front Panel Controls and Indicators).
5. Set the programming source to $5.0V \pm 1mV$.
6. Verify that the unit is set to $100\% \pm 0.25\%$ of full-scale output voltage. If necessary adjust R74 for 100% output voltage.
7. Set the programming source to $0.5V \pm 1mV$.

8. Verify that the unit is set to $10\% \pm 0.25\%$ of full-scale output voltage. If necessary adjust R90 for 10% output voltage.
9. Remove all connections to the remote analog control connector (J1). Place the jumper between pins 5 and 6. This returns the SGI series unit to local, front panel control.
10. Repeat the steps above as required to obtain the required accuracy.

**WARNING!**

Hazardous voltages may be present on the output after the output is disabled due to stored capacitive charge. Allow 5 minutes to drain the output capacitive charge to safe levels before connecting or removing output wiring.

4.2.3 Resistor Programming Current Sources

(Standard non-isolated Analog Control interface)

1. Disable AC power to the unit.
2. Connect the power supply to a precision current shunt (see Figure 4-1, Section 4.1.2 Preparation).
3. Set the SGI series unit to operate in remote current programming mode using resistance by connecting a 5K ohm (1% or better tolerance) resistor as shown in Figure 3-7 in Section 3.10 Remote Current Programming.
4. Attach a precision meter across the shunt Kelvin terminals.
5. Apply AC power and press Output On button (see Section 3.2.1, Front Panel Controls).
6. Adjust R35 to measure 100% Current Output.
7. Disable AC power to the unit.
8. Set the SGI series unit to operate in remote voltage programming mode using resistance by connecting a 5K ohm (1% or better tolerance) resistor as shown in Figure 3-9 in Section 3.11 Remote Voltage Programming.
9. Apply AC power and enable the unit via the front panel On/Off switch.
10. Adjust R33 to measure 100% Output Voltage.
11. Disable AC power and remove all connections to the remote analog control connector (J1), except the jumper between pins 5 and 6.

4.2.4 Change Calibration Date

To change the calibration date stored in memory, issue the following SCPI commands (see SG Series Programming Manual for command details) via RS232 or GPIB or Ethernet:

VIA RS232 OR GPIB

```
CAL:UNLOCK "6867"  
CAL:DATE YYYYMMDD  
CAL:STORE  
CAL:LOCK
```

VIA ETHERNET

```
CAL:UNLOCK "6867"  
CAL:MOD;LASTCALDATE MM DD YYYY  
CAL:MOD:NEXTCALDATE MM DD YYYY  
CAL:STORE  
CAL:LOCK
```

4.3 Isolated Analog (Option) Verification and Calibration Procedure

All calibration potentiometers can be adjusted through access holes in the top cover of the SGI Series unit. It is **not** necessary to remove the top cover to perform the calibration procedures.

4.3.1 Current Mode

1. Set the SGI series unit to operate in remote current programming mode using an external 0-5 VDC voltage source as shown in Figure 3-8 in Section 3.10 Remote Current Programming.
2. Connect a precision shunt as shown in Figure 4-1.
3. Attach a precision meter across the shunt Kelvin terminals.
4. Attach a precision meter in parallel with the voltage programming source.
5. Set the voltage source to $0.0V \pm 1mV$.
6. Apply AC power and program the voltage to 100% of rated output voltage. Enable the output.
7. Set the programming voltage to $5.0V \pm 1mV$.
8. Verify that the unit is set to $100\% \pm 0.8\%$ of full scale output current. If necessary, adjust R33 for 100% of full scale current on the shunt.

9. Set the programming source for $0.5V \pm 1mV$.
10. Verify that the unit is set to $10\% \pm 0.8\%$ of full scale output current. If necessary, adjust R47 for 10% of full scale current on the shunt.
11. Repeat the steps above as needed to obtain the required accuracy.

4.3.2 Voltage Mode

1. Disable AC power to the unit. Remove the current shunt from the output and verify that there is no load attached.
2. Remove the precision meter leads from the current shunt and apply them across the output terminals.
3. Set the SGI series unit to operate in remote voltage programming mode using an external 0-5 VDC voltage source as shown in Figure 3-10 in Section 3.11, Remote Voltage Programming.
4. Apply AC power and program the current to 100% of rated output current. Enable the output.
5. Verify that the unit is set to $0V \pm 0.25\%$ of full-scale output voltage. If necessary adjust R35 to obtain zero output volts. (See Figure 4-2.)
6. Set the programming voltage to $5.0V \pm 1mV$.
7. Verify that the unit is set to $100\% \pm 0.25\%$ of full-scale output voltage. If necessary adjust R39 for 100% output voltage.
8. Set the programming source to $0.5V \pm 1mV$.
9. Verify that the unit is set to $10\% \pm 0.25\%$ of full-scale output voltage. If necessary adjust R35 for 10% output voltage.
10. Repeat the steps above as needed to obtain the required accuracy.
11. Remove all connections to the remote analog control connector (J1), except the jumper between pins 5 and 6. This returns the supply to local, front panel control.

**CAUTION!**

Hazardous voltages may be present on the output after the output is disabled due to stored capacitive charge. Allow 5 minutes to drain the output capacitive charge to safe levels before connecting or removing output wiring.

4.3.3 Change Calibration Date

To change the calibration date stored in memory, issue the following SCPI commands (see SG Series Programming Manual for command details) via RS232 or GPIB or Ethernet:

VIA RS232 OR GPIB

```
CAL:UNLOCK "6867"  
CAL:DATE YYYYMMDD  
CAL:STORE  
CAL:LOCK
```

VIA ETHERNET

```
CAL:UNLOCK "6867"  
CAL:MOD;LASTCALDATE MM DD YYYY  
CAL:MOD:NEXTCALDATE MM DD YYYY  
CAL:STORE  
CAL:LOCK
```

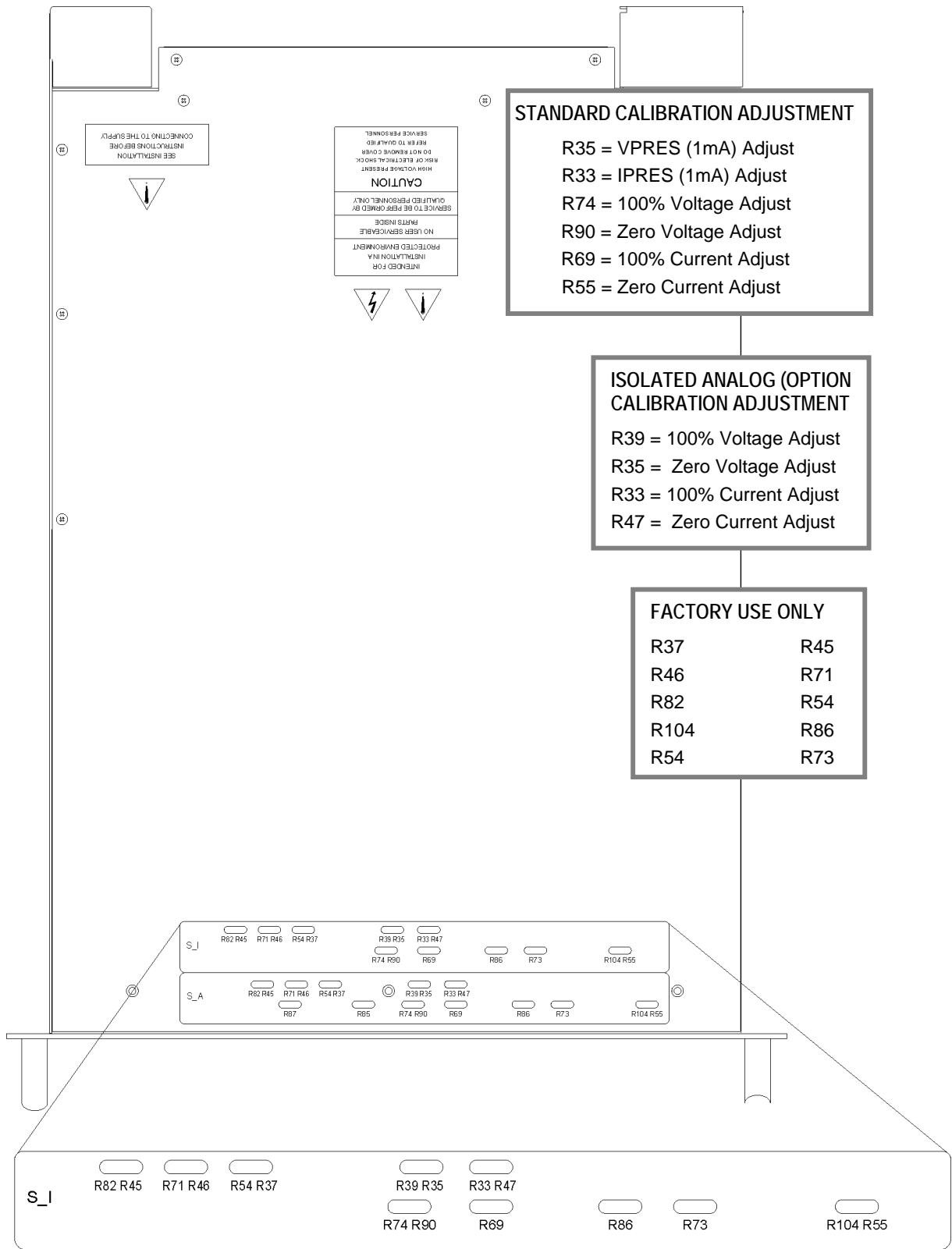

Figure 4-2. Potentiometer Locations

(Note that in units without access holes in the top, the potentiometers are mapped to the same location under the top cover)

SECTION 5 MAINTENANCE

5.1 Introduction

This chapter contains preventive maintenance information for the SGI Series power supplies.



WARNING!

All maintenance that requires removal of the cover of the unit should only be done by properly trained and qualified personnel. Hazardous voltages exist inside the unit. Disconnect the supply from the input power before performing any maintenance. Service, fuse verification, and connection of wiring to the chassis must be accomplished at least *five minutes* after power has been removed via external means; all circuits and/or terminals to be touched must be safety grounded to the chassis.

5.2 Preventive Maintenance

No routine maintenance on the SGI Series is required, aside from periodic cleaning of the unit when needed:

- Once a unit is removed from service, vacuum all air vents, including the front panel grill. Clean the exterior with a mild solution of detergent and water. Apply the solution onto a soft cloth, not directly to the surface of the unit. To prevent damage to materials, do not use aromatic hydrocarbons or chlorinated solvents for cleaning.
- Low-pressure compressed air may be used to remove dust from in and around components on the printed circuit boards.



WARNING!

The OFF position of the power switch does not remove voltage from the input terminal blocks. Remove all external power before performing any service.

An annual inspection of the SGI Series unit is recommended. Table 5.1 lists the visual inspection checks to be performed, and the corrective action to be taken.

Item	Inspect For	Corrective Action
External connector plugs and jacks	Looseness, bent or corroded contacts, damage or improper seating in mating connector	Clean contacts with solvent moistened cloth, soft bristle brush, small vacuum, or low compressed air.
		Replace connectors damaged, deeply corroded, or improperly seated in mating connector.
Chassis, fan, and extruded heatsinks	Dirt and corrosion	Clean with cloth moistened with soapy water.
External electrical wiring	Broken, burned or pinched wire; frayed, worn or missing insulation	Repair or replace defective wires.
External solder connections	Corrosion, loose, cracked, or dirty connections	Clean and resolder connections.
Dirt and moisture buildup	Short circuits, arcing, corrosion, overheating	Clean as required.
Front panel controls and meters	Dirt and corrosion	Clean with cloth moistened with soapy water.
		Use a Kimwipe tissue and GTC glass-cleaning compound to clean the meter faces.

Table 5.1 Recommended Annual Inspection



CAUTION!

For safe and continued operation of the SGI Series, always operate the unit in a temperature and humidity controlled, indoor area, free of conductive contaminants. Remember to keep the rear and sides of the unit free of obstructions to ensure proper ventilation.

5.3 Fuses

There are no user replaceable components in the power supply.



WARNING!

Only properly trained and qualified personnel should remove the cover from the power supply. Service, fuse verification, and connection of wiring to the chassis must be accomplished at least *five minutes* after power has been removed via external means; all circuits and/or terminals to be touched must be safety grounded to the chassis.



CAUTION!

To reduce the risk of fire or electrical shock, replace fuses only with the same type and rating.

Internal fuses are listed in Table 5.2. Note, however, that failure of one of these fuses indicates a more serious problem has occurred. Please contact the factory for further assistance.

PCB Part No.	Reference	Value	Manufacturer Part No.
Bias Supply 5546345 or 5540068	F1, F2, F3	600 Volt, 5 Amp	Littelfuse KLK-5
Module Controller 5556210, 5550322, or 5550610	F1, F2, F3	600 Volt, 30 Amp	Littelfuse KLKD30

Table 5.2 Fuse Values

This page intentionally left blank.

INDEX

- A
 - Aborting an edit, **3-9**
- B
 - Basic Sequence Operation, **3-17**
- C
 - Calibration and Verification, 4-1
 - Circuit Breaker Requirements, 2-3, 2-5
 - Controls and Indicators, 3-1
 - Analog Control (J1), 3-35
 - Current Mode
 - Operation, 3-32
 - Verification and Calibration, 4-3
- D
 - Default Programming, 3-32
 - Display Brightness, 3-26
 - Display Elements, 3-6
- E
 - Editing, 3-8
- F
 - Front Panel, 3-1
 - Functions, 3-14
 - Fuses, 5-3
- H
 - Home Menu, 3-10
 - Home Timeout, 3-26
- I
 - Inductive Loads, 2-8
 - Input/Output Connections, 2-3
 - Connector Functions, 2-3
 - Isolated Analog Control, 3-35
- J
 - J1 Connector, 3-35
- L
 - Language, 3-26
 - Loads
 - Inductive, 2-8
 - Location and Mounting, 2-2
 - Lock Key, 3-26
- M
 - Maintenance
 - Annual Inspection, 5-2
 - Fuses, 5-3
 - Preventive, 5-1
 - Master/Slave Operation, 3-48
 - Menu Map, 3-10
 - Mounting Hardware, 2-2
- N
 - Navigation, 3-6
 - Noise, 1-4
- O
 - Operation
 - Current Mode, 3-32

Local, 3-31
Master/Slave, 3-48
Parallel, 3-48
Remote Current Programming, 3-39
Remote Output On/Off Control, 3-45
Remote Overvoltage Setpoint, 3-46
Remote Sensing, 3-43
Remote Shutdown, 3-47
Remote Voltage Programming, 3-41
Series, 3-50
Voltage Mode, 3-32
Operations, Step, 3-19
Overvoltage Protection, 3-33
Ozone Precaution, 1-2

P

Parallel Operation, 3-48
Power Mode, 3-25
Programming Current, 3-15
Programming Overvoltage, 3-15
Programming V/I/P, 3-14
Programming Voltage, 3-14

R

Rack slides, 2-2
Recall, 3-16
Remote Current Programming, 3-39
Remote Mode, 3-27
Remote Output On/Off Control, 3-45
Remote Overvoltage Setpoint, 3-46
Remote Sensing, 3-43
Remote Shutdown, 3-47
Remote Voltage Programming, 3-41
Ripple, 1-4

S

Save V/I/OVP Settings, 3-15

Saving to Power ON, 3-16
Screens
 Other screens, 3-14
 Warning, 3-14
Sequencing, 3-17
Sequencing Examples, 3-22
Series Operation, 3-50
Setup, 3-31
SGI Initial Start-up, 3-5
Single Step, 3-18
Specifications, 1-1
 Current, 1-4
 Electrical Characteristics, 1-2
 Environmental Characteristics, 1-2
 Noise, 1-4
 Physical Characteristics, 1-4
 Ripple, 1-4
 Voltage, 1-4
Step Operations, 3-19
Supply Info, 3-27

T

Total System Current, 3-30

V

Ventilation, 2-2
Verification and Calibration, 4-2
 Current Mode, 4-3
 Isolated Analog (Option), 4-5
Voltage Mode
 Operation, 3-32

W

Warning Screens, 3-31
Wire Size, 2-5

About AMETEK

AMETEK Programmable Power, Inc., part of the Programmable Power Division of AMETEK, Inc., is the new global leader in the design and manufacture of precision, programmable power supplies for R&D, test and measurement, process control, power bus simulation and power conditioning applications across diverse industrial segments. From bench top supplies to rack-mounted industrial power subsystems, AMETEK Programmable Power is the proud manufacturer of Elgar, Sorensen, California Instruments and Power Ten brand power supplies.

Headquarters, AMETEK, Inc. is a leading global manufacturer of electronic instruments and electromechanical devices with annualized sales of \$2.5 billion. The Company has over 11,000 colleagues working at more than 80 manufacturing facilities and more than 80 sales and service centers in the United States and around the world.

Trademarks

AMETEK is a registered trademark of AMETEK, Inc.

Other trademarks, registered trademarks, and product names are the property of their respective owners and are used herein for identification purposes only.

Notice of Copyright

SGL Series DC Power Supplies Operation Manual © April 2010 AMETEK Programmable Power, Inc. All rights reserved.

Exclusion for Documentation

UNLESS SPECIFICALLY AGREED TO IN WRITING, AMETEK PROGRAMMABLE POWER INC. ("AMETEK")

(a) MAKES NO WARRANTY AS TO THE ACCURACY, SUFFICIENCY OR SUITABILITY OF ANY TECHNICAL OR OTHER INFORMATION PROVIDED IN ITS MANUALS OR OTHER DOCUMENTATION.

(b) ASSUMES NO RESPONSIBILITY OR LIABILITY FOR LOSSES, DAMAGES, COSTS OR EXPENSES, WHETHER SPECIAL, DIRECT, INDIRECT, CONSEQUENTIAL OR INCIDENTAL, WHICH MIGHT ARISE OUT OF THE USE OF SUCH INFORMATION. THE USE OF ANY SUCH INFORMATION WILL BE ENTIRELY AT THE USER'S RISK, AND

(c) REMINDS YOU THAT IF THIS MANUAL IS IN ANY LANGUAGE OTHER THAN ENGLISH, ALTHOUGH STEPS HAVE BEEN TAKEN TO MAINTAIN THE ACCURACY OF THE TRANSLATION, THE ACCURACY CANNOT BE GUARANTEED. APPROVED AMETEK CONTENT IS CONTAINED WITH THE ENGLISH LANGUAGE VERSION, WHICH IS POSTED AT WWW.PROGRAMMABLEPOWER.COM.

Date and Revision

April 2010 Revision R

Part Number

M550221-01

Contact Information

Telephone: 800 733 5427 (toll free in North America)
858 450 0085 (direct)
Fax: 858 458 0267
Email: sales@programmablepower.com
service@programmablepower.com
Web: www.programmablepower.com

This page intentionally left blank.

Important Safety Instructions

Before applying power to the system, verify that your product is configured properly for your particular application.

	Hazardous voltages may be present when covers are removed. Qualified personnel must use extreme caution when servicing this equipment. Circuit boards, test points, and output voltages also may be floating above (below) chassis ground.
	The equipment used contains ESD sensitive ports. When installing equipment, follow ESD Safety Procedures. Electrostatic discharges might cause damage to the equipment.

Only *qualified personnel* who deal with attendant hazards in power supplies, are allowed to perform installation and servicing.

Ensure that the AC power line ground is connected properly to the Power Rack input connector or chassis. Similarly, other power ground lines including those to application and maintenance equipment *must* be grounded properly for both personnel and equipment safety.

Always ensure that facility AC input power is de-energized prior to connecting or disconnecting any cable.

In normal operation, the operator does not have access to hazardous voltages within the chassis. However, depending on the user's application configuration, **HIGH VOLTAGES HAZARDOUS TO HUMAN SAFETY** may be normally generated on the output terminals. The customer/user must ensure that the output power lines are labeled properly as to the safety hazards and that any inadvertent contact with hazardous voltages is eliminated.

Guard against risks of electrical shock during open cover checks by not touching any portion of the electrical circuits. Even when power is off, capacitors may retain an electrical charge. Use safety glasses during open cover checks to avoid personal injury by any sudden component failure.

Neither AMETEK Programmable Power Inc., San Diego, California, USA, nor any of the subsidiary sales organizations can accept any responsibility for personnel, material or inconsequential injury, loss or damage that results from improper use of the equipment and accessories.

SAFETY SYMBOLS

	WARNING Risk of Electrical Shock		CAUTION Refer to Accompanying Documents
	Off (Supply)		Direct Current (DC)
	Standby (Supply)		Alternating Current (AC)
	On (Supply)		Three-Phase Alternating Current
	Protective Conductor Terminal		Earth (Ground) Terminal
	Fuse		Chassis Ground

This page intentionally left blank.

Product Family: SGI Series DC Power Supplies

Warranty Period: Five Years

WARRANTY TERMS

AMETEK Programmable Power, Inc. ("AMETEK") provides this written warranty covering the Product stated above, and if the Buyer discovers and notifies AMETEK in writing of any defect in material or workmanship within the applicable warranty period stated above, then AMETEK may, at its option: repair or replace the Product; or issue a credit note for the defective Product; or provide the Buyer with replacement parts for the Product.

The Buyer will, at its expense, return the defective Product or parts thereof to AMETEK in accordance with the return procedure specified below. AMETEK will, at its expense, deliver the repaired or replaced Product or parts to the Buyer. Any warranty of AMETEK will not apply if the Buyer is in default under the Purchase Order Agreement or where the Product or any part thereof:

- is damaged by misuse, accident, negligence or failure to maintain the same as specified or required by AMETEK;
- is damaged by modifications, alterations or attachments thereto which are not authorized by AMETEK;
- is installed or operated contrary to the instructions of AMETEK;
- is opened, modified or disassembled in any way without AMETEK's consent; or
- is used in combination with items, articles or materials not authorized by AMETEK.

The Buyer may not assert any claim that the Products are not in conformity with any warranty until the Buyer has made all payments to AMETEK provided for in the Purchase Order Agreement.

PRODUCT RETURN PROCEDURE

1. Request a Return Material Authorization (RMA) number from the repair facility (**must be done in the country in which it was purchased**):
 - **In the USA**, contact the AMETEK Repair Department prior to the return of the product to AMETEK for repair:
Telephone: 800-733-5427, ext. 2295 or ext. 2463 (toll free North America)
858-450-0085, ext. 2295 or ext. 2463 (direct)
 - **Outside the United States**, contact the nearest Authorized Service Center (ASC). A full listing can be found either through your local distributor or our website, www.programmablepower.com, by clicking Support and going to the Service Centers tab.
2. When requesting an RMA, have the following information ready:
 - Model number
 - Serial number
 - Description of the problem

NOTE: Unauthorized returns will not be accepted and will be returned at the shipper's expense.

NOTE: A returned product found upon inspection by AMETEK, to be in specification is subject to an evaluation fee and applicable freight charges.

This page intentionally left blank.